



Deva 100 (Model 8220)

Wood-fired Cook Stove

OWNER'S MANUAL INSTALLATION AND OPERATING INSTRUCTIONS



We recommend that our products be installed and serviced by professionals who are certified in the U.S. by NFI (National Fireplace Institute).

www.nficertified.org



CONTACT LOCAL AUTHORITIES HAVING JURISDICTION (BUILDING DEPARTMENT or FIRE OFFICIALS) ABOUT PERMITS REQUIRED, RESTRICTIONS AND INSTALLATION INSPECTION IN YOUR AREA.

PLEASE READ THIS ENTIRE OWNER'S MANUAL BEFORE YOU INSTALL AND USE YOUR NEW *Deva 100* COOK STOVE. To reduce the risk of fire, follow the installation instructions. Failure to follow these instructions may result in property damage, bodily injury, or even death.

SAVE THESE INSTRUCTIONS FOR FUTURE REFERENCE!

TABLE OF CONTENTS

INTRODUCTION.....	3
CODES	3
SAFETY INFORMATION	3
PERIODIC CHECKLIST	4
EMERGENCY PROCEDURES.....	5
SPECIFICATIONS.....	6
INSTALLATION.....	7
UNPACKING.....	7
INSTALLING YOUR STOVE.....	7
CLEARANCES TO NFPA 211 PROTECTED SURFACES.....	7
HEARTH REQUIREMENTS AND FLOOR PROTECTION	8
CLEARANCES TO COMBUSTIBLES	9
ALCOVE REQUIREMENTS:.....	10
VENTING COMPONENTS AND CONFIGURATION.....	11
Components of a Venting System.....	11
Installing a Venting System.....	11
CONNECTING YOUR WOOD-FIRED COOK STOVE	12
Connecting to a Prefabricated Metal Chimney.....	12
OPERATION.....	16
CONTROLS AND FEATURES.....	16
CHOOSING FIREWOOD.....	17
BUILDING YOUR FIRST FIRE	18
Building A Fire	18
Burn Rate	19
Over-Fire Caution.....	19
Removal And Disposal Of Ashes	19
Creosote Formation And Need For Removal	20
Gaskets.....	20
Glass.....	20
MAINTENANCE OF THE GLASS COOK TOP	21
CLEANING OF THE GLASS COOK TOP	21
Cast Iron.....	21
TROUBLESHOOTING	22
TROUBLESHOOTING GUIDE	23
REPLACEMENT PARTS & OPTIONAL ACCESSORIES.....	24
SAFETY LABEL	25
WARRANTY REGISTRATION	26

Introduction

Congratulations! You have just invested in a most unique wood burning cook stove – the **Deva 100** from Hearthstone Quality Home Heating Products, Inc®. The **Deva 100** Model 8220 is a wood burning cook-stove. At 1.6 cubic feet firebox and 2.47 cubic feet oven capacity you can be proud to join the Hearthstone family with our *Premier* Wood Burning Cook stove. The generous door height allows for loading of wood through the front up to 17” inches long!

Your purchase ensures years of clean, comfortable heat and cooking with minimal maintenance. The **Deva 100** blends modern technology with the unique beauty of cast iron. We trust that you will appreciate the quality of our handcrafted product.

Please read this manual in its entirety. Its purpose is to familiarize you with your cook stoves safe installation, operation and maintenance. It contains information that will be useful to you now and in years to come, so keep it handy and refer to it as needed.

Use these instructions as well as national, state, and local building codes to install your cook stove. Be sure to maintain the designated stovepipe and cook stove clearances to walls, ceilings, hearth, and other combustible surfaces. This will help reduce the risk of fire. Failure to follow these instructions can result in property damage, bodily injury, and even death.

Locate your cook stove in a safe, convenient, open area; away from traffic flow, doors, and hallways; and near a chimney and chimney connector. Review the proper clearance measurements from combustible surfaces. You can safely reduce required clearances in most cases with a special connector pipe and special wall coverings as specified by this manual, the NFPA 211 codes, and your local authorities having jurisdiction.

Keep furniture, drapes, curtains, wood, paper, and other combustibles far away from the stove. Never install the cook stove in a location where gasoline, kerosene, charcoal lighter fluid or other flammable liquids are used or stored.

 **SAFETY NOTICE: A HOUSE FIRE MAY RESULT IF THIS COOK STOVE IS NOT INSTALLED PROPERLY. FOR YOUR SAFETY, CAREFULLY FOLLOW THE INSTALLATION DIRECTIONS. CONTACT LOCAL BUILDING OR FIRE OFFICIALS ABOUT RESTRICTIONS AND INSTALLATION INSPECTION IN YOUR AREA.**

The performance of your stove depends on many variables. Since all installations are unique, the general information and operating procedures presented here can only serve as useful if you have any questions; do not hesitate to contact your dealer for additional information.

Validate your warranty - return your warranty registration card to Hearthstone within 30 days of purchase to validate your warranty. Contact your dealer for any necessary warranty service.

This cook stove is manufactured and warranted by:

Hearthstone Quality Home Heating Products, Inc®
317 Stafford Ave.
Morrisville, VT 05661
www.hearthstonestoves.com

CODES

When you install your Deva, it is imperative that you adhere to all local codes, which can be obtained from either of the following two national sources:



American National Standards Institute, Inc. (ANSI)
1430 Broadway
New York, NY 10018
www.ansi.org

National Fire Protection Association, Inc. (NFPA)
Battery March Park
Quincy, MA 02269
www.nfpa.org



SAFETY INFORMATION

Read and understand this Owner's Manual thoroughly before installing and using this stove.

Ensure you install your stove:

-  According to the manufacturer's recommendations.
-  In accordance with all applicable codes.
-  With the proper sized chimney.

When using your stove:

-  Warn children and others unfamiliar with wood-fired cook stoves the danger of touching hot, radiating surfaces of your stove. For your additional safety, obtain hearth and stove guards through your local dealer. Keep pets away from the stove to prevent unnecessary hazards.
-  Burn natural wood only. Higher efficiencies and lower emissions result when burning air-

dried, seasoned wood, as compared to green or freshly cut wood.

- 🔥 Use caution when loading firewood into a hot stove.
- 🔥 Keep the fuel loading door closed at all times except when loading wood.
- 🔥 Keep the ash pan tray fully inserted.
- 🔥 Avoid grease build-up when cooking on the top surface. Clean the surface regularly after using the cook top surface.
- 🔥 **Use care when cooking on the glass top. Scratching the surface will weaken and shorten the life of the glass. (Pick up your cooking pots pans instead of sliding them on the surface.)**
- 🔥 **Never** modify this cook stove in any way.
- 🔥 **Never** burn kiln dried wood, painted or treated wood, solvents, trash, plywood, colored or glossy paper, artificial logs, cardboard, coal, garbage or driftwood. *Especially, do not burn coal in this stove.*
- 🔥 **Never** Use gasoline type fuel, kerosene, charcoal lighter fluid, or other liquid fuels or solid fire starters to start or invigorate the fire. These fuels can possibly generate carbon monoxide, which can sap the supply of oxygen or even create an explosion. Keep all such materials away from the stove.
- 🔥 **Never** use a wood grate andirons or other device to elevate the fire.
- 🔥 **Do not** allow logs to rest against or otherwise come in contact with the glass when the door is closed.
- 🔥 **Do not** slam the door or use it to force wood in to the cook stove.
- 🔥 **Never** over-fire your cook stove. (See page 19)
- 🔥 **Never** put articles of clothing or candles on a hot cook stove.
- 🔥 **Do not** connect the cook stove to a flue that is serving another appliance.
- 🔥 **Do not** set any materials on the cook top that are not intended. The surface will become very hot during operation and even though ignition may or may not take place the heat will melt or burn most objects which may in turn drip into the firebox will may create an ignition.

Other safety guidelines

- 🔥 Keep all combustible items such as furniture, drapes, clothing, and other items, at least 36" (0.92 m) from the cook stove (See page 9) for more clearance to combustibles information)

- 🔥 Install a smoke detector.
- 🔥 Keep a fire extinguisher handy. We recommend the type rated "A B C."
- 🔥 Dispose of ashes properly. (See page 19)

PERIODIC CHECKLIST

Perform each of these tasks at the specified intervals. (While these are to be used as a rule of thumb, Hearthstone recommends that a qualified service technician inspect your wood burning system approximately every other month during heavy use).

Every Week:

- 🔥 Empty ashes from the firebox and ash pan, sooner if the firebox is full.

Every Month:

- 🔥 Visually inspect chimney connector and chimney for creosote; clean accordingly.
 - Tap the outside of the pipe to feel for buildup of creosote. If the pipe feels hollow, your pipe is most likely clean and safe for use. If the pipe feels solid or full, it probably has accumulated creosote and should be cleaned before further use.

Every Other Month:

- 🔥 A visual inspection of the chimney connector and chimney for creosote is recommended depending upon your use of the stove.
- 🔥 Check the fuel loading door seal using the "dollar bill test." (When the fire is out and the stove is cool, shut the door on a dollar bill. If the bill pulls out without any resistance, then your stove's door isn't sealed properly.) To tighten the seal, change the door gasket.

Every Season:

Have a qualified service technician inspect your chimney and wood burning system.

- 🔥 Dismantle the chimney connector and clean it thoroughly. Replace any pieces that show signs of rust or deterioration.
- 🔥 Inspect and, if necessary, clean your chimney.
- 🔥 Thoroughly clean out the inside of the stove.
- 🔥 Inspect all door gasket material and replace if worn, frayed, cracked or extremely hard.
- 🔥 Clean and inspect the oven and oven door components.

EMERGENCY PROCEDURES

If you have a stovepipe or chimney fire, follow these instructions:

1. If the fire is too threatening, leave the area and call the fire department immediately! If not, perform the next three steps.
2. Close the primary air control.
3. Close the stovepipe damper (if present).
4. Keep all doors to the stove closed!

 **WARNING: DO NOT ATTEMPT TO PUT OUT A STOVEPIPE OR CHIMNEY FIRE BY THROWING WATER ONTO THE STOVE, STOVEPIPE, OR CHIMNEY. THE EXTREMELY HIGH TEMPERATURE ASSOCIATED WITH SUCH FIRES CAN CAUSE INSTANT-ANEOUS STEAM AND SERIOUS BODILY HARM.**

Once the chimney fire has expired, leave the primary air control closed and let the fire in the stove die out completely. The cook stove should not be fired again until the stove, stovepipe, and chimney are all thoroughly inspected for any sign of damage. You must correct any damage before using your cook stove again.



Specifications

Oven Capacity: 2.47 cubic feet

Firebox Capacity 1.6 cubic feet

Maximum Heat Output: 46,000 BTUs per hour of cordwood (based on independent laboratory test results)

Maximum Log Length: 17" (43 cm) fuel loading door

Height: 33-3/4" (85 cm)

Width: 40" (102 cm)

Depth: 23 3/4" (60 cm)

Fuel loading door dimension: 7"x 9-3/4"
(18 cm x 25 cm)

Stovepipe Size 6" (15.2 cm) diameter

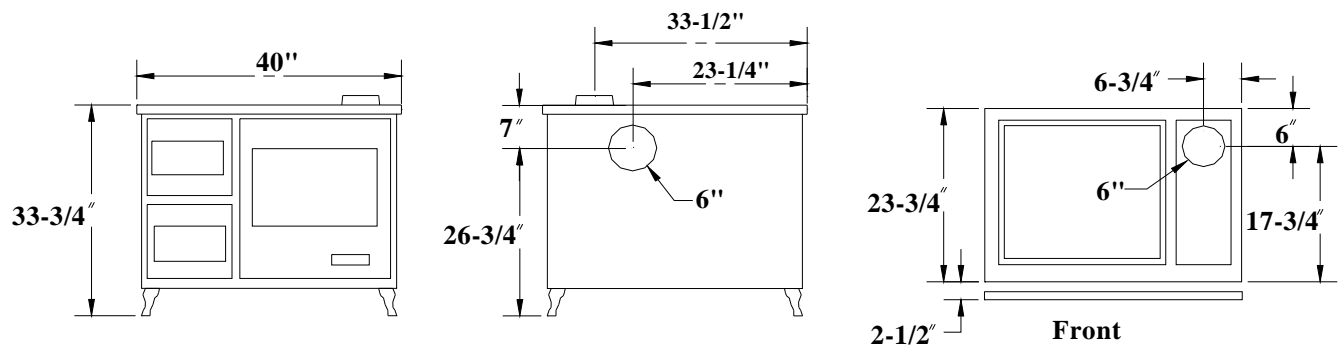

Installation

UNPACKING

Hearthstone packages your Deva 100 cook stove with the greatest care, so that it ships safely. Under certain circumstances, however, damage can occur during transit and handling. When you receive your cook stove, unpack it carefully, inspecting your stove and all parts for damage. Also, make sure that all parts are included in the box. If any parts are damaged or missing, please contact your dealer immediately.

INSTALLING YOUR STOVE

 **The Deva 100 is not approved for installation in a mobile home.**

The Deva 100 Cook stove does not require the use of additional outside air for combustion. There is no kit available for this installation so please keep this in mind when installing and planning your Deva 100.

First you must decide where your stove will reside. After choosing an appropriate spot, inspect this location to make sure that the stove will have enough clearance to combustible materials. These combustibles can include walls, floor, ceiling, cabinets, fireplace, and chimney. You must carefully consider the clearances to all of these combustibles before actually connecting your cook stove. When considering these clearances, also decide the kind of floor the stove will rest on. Depending on your floor, you can install your stove as it is, or use a floor protector, some types of flooring may require additional floor protection.

Please use this section to plan how to locate your stove.

Read this chapter to obtain a sound understanding of how to properly install your stove.

If you use a close clearance connector pipe, it must be tested to UL standards and listed.

Check the listing for your pipe for actual clearances. The diagrams in this manual represent typical installations, but are specific to the Simpson Dura-Vent DVL brand. Clearances cannot be reduced without the use of close clearance connector pipe and/or by protecting the surfaces per NFPA 211 standards.

CLEARANCES TO NFPA 211 PROTECTED SURFACES

You can reduce the clearances to combustible surfaces by using any National Fire Protection Agency (NFPA) approved wall protection system. Please refer to NFPA 211 for specifications and complete details. You can obtain this information directly from NFPA.

National Fire Protection Agency
Batterymarch Park
Quincy, MA 02269
1-800-344-3555
1-617-770-3000

HEARTH REQUIREMENTS AND FLOOR PROTECTION

Install your stove on the following:

- 🔥 A non-combustible floor protector that you obtain from your dealer, or any other noncombustible material (metal, glass, stone, tile, etc.). A floor protector is any noncombustible surface laid on the floor underneath the stove that extends, 16 inches - US (or 46 cm in Canada) beyond the fuel loading door and 8 inches (20 cm) beyond each side of the cook stove. (See Figure 1) The hearth protection for your Deva 100 must have an R-value of at least 0.89 or be a UL Listed floor protection.

An example of a non-combustible floor protector would be a hearth constructed with a continuous layer of a listed backer board (such as Micore, Wonder-Board or Durock) used for ember protection with a tile, brick, slate, or another non-combustible facing.

For horizontal chimney connector installations, the floor protection must be installed beneath the connector and 2" beyond each side.

Floor protector's come with various types of specifications. To convert a floor protector's specification to an R-value, do one of the following:

- If the R-value is given, use that value—no conversion is needed.
- If a K-factor is given with a required thickness (T) in inches, use this formula:
 $R\text{-value} = 1/K \times T$
- If a C-factor is given, use the formula:
 $R\text{-value} = 1/C$

To determine the R-value of the proposed alternate floor protector:

- Use either the K-factor or the C-factor formula explained above to convert specifications not expressed as R-values.
- For multiple layers of floor protectors, simply add the R-values of each layer to determine the overall R-value of the layers.

If the overall R-value of your setup is greater than the R-value of the specified floor protector, then your setup is acceptable.

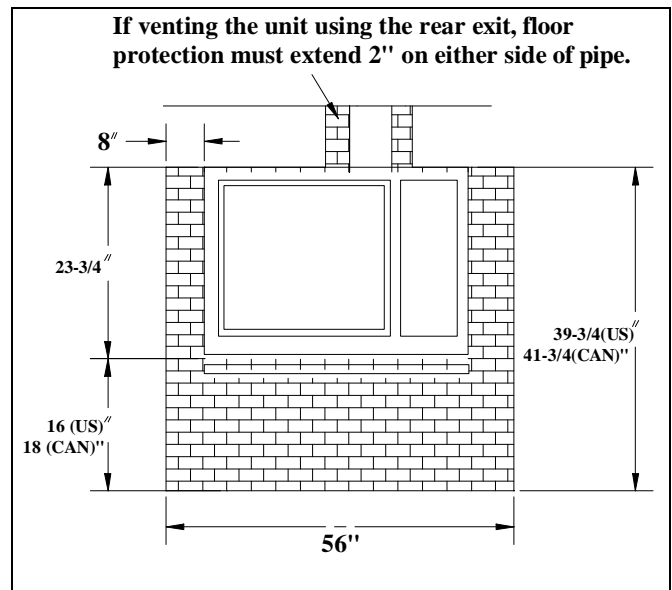

Figure 1 - Hearth Protection for top vent installations

CLEARANCES TO COMBUSTIBLES

Use this section to plan the layout for your stove. Consider clearance of *pipe* to combustibles and *cook stove* to combustibles.

You must follow minimum clearances for the Deva 100 cook stove to combustibles such as walls and ceilings. You may reduce the general clearances if installing the stove near *Protected Surfaces*.

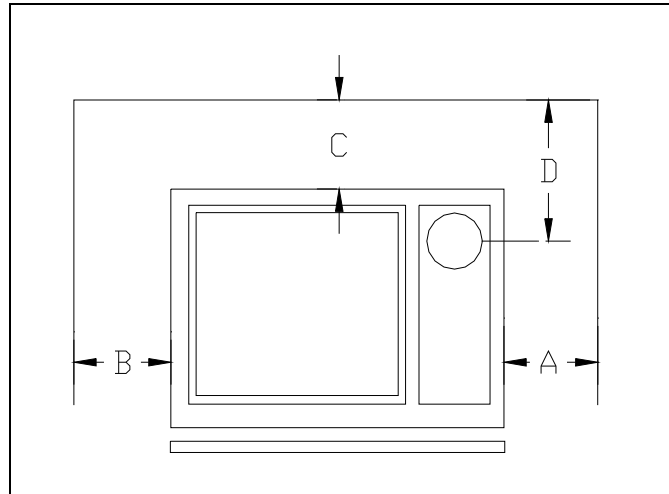

Figure 2 - Clearance to Combustibles

MINIMUM CLEARANCES TO COMBUSTIBLES (from closest point of stove)

Clearan	Single wall connector				Double walls connector			
	Top Exit		Rear Exit		Top Exit		Rear Exit	
	(in)	(cm)	(in)	(cm)	(in)	(cm)	(in)	(cm)
A	10	26	4	11	4	11	4	11
B	10	26	4	11	4	11	4	11
C	16	41	16	41	14	36	16	41
D	21.5	55	n/a	n/a	19.5	50	n/a	n/a

ALCOVE	Top exit connector			
	Single wall connector		Double wall connector	
	(in)	(cm)	(in)	(cm)
A	7	18	4	11
B	16	41	14	36
C	16	41	14	36
D	21.5	55	19.5	50

ALCOVE REQUIREMENTS:

- 🔥 Maximum alcove depth is 48"/122cm
- 🔥 Minimum alcove height is 96"/ 2439cm
- 🔥 Minimum alcove width is 63"/ 160cm (with single wall connector)
- 🔥 Minimum alcove width is 58"/ 147cm (with double wall connector)

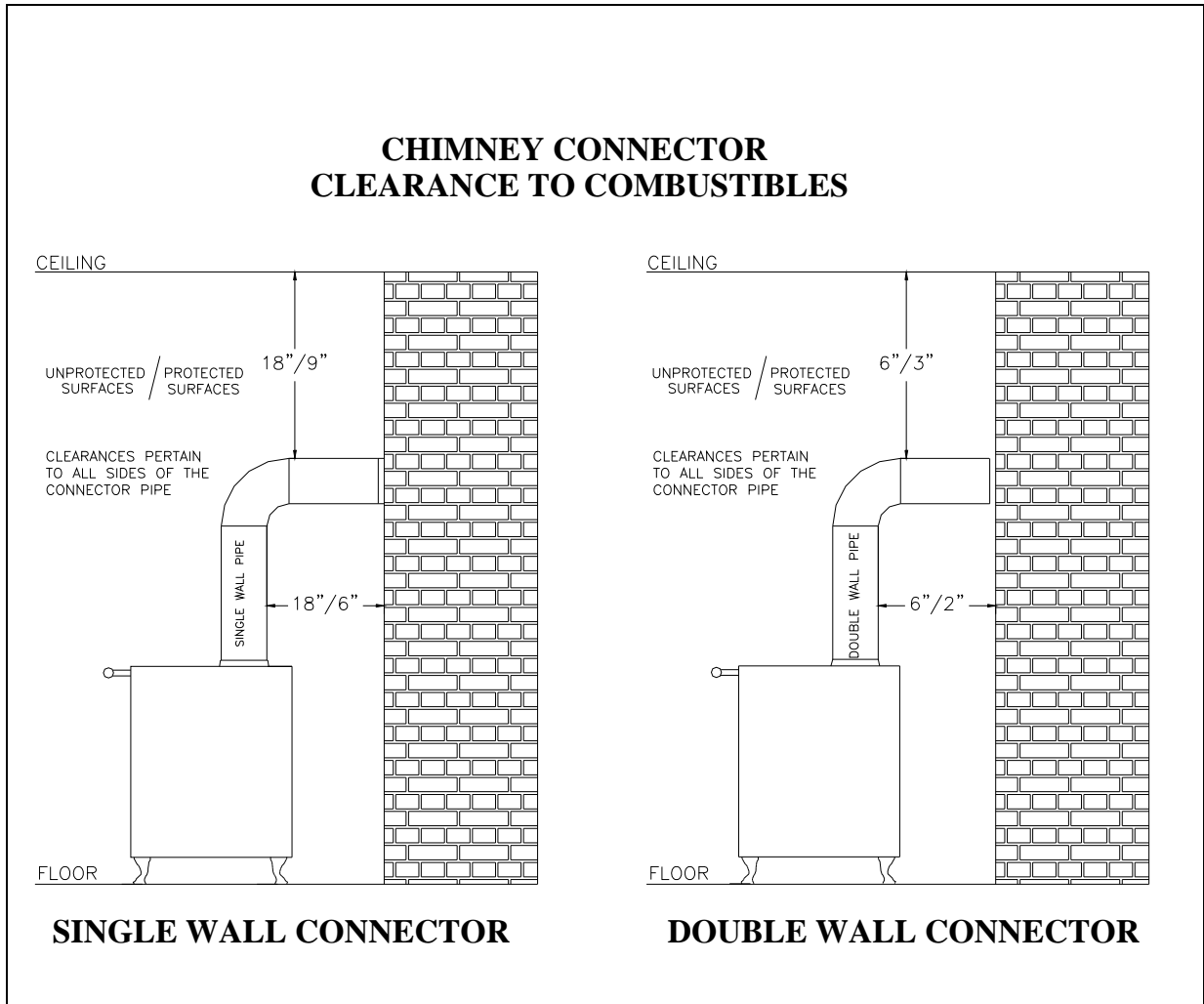

VENTING COMPONENTS AND CONFIGURATION

COMPONENTS OF A VENTING SYSTEM

DO NOT CONNECT THIS UNIT TO A CHIMNEY FLUE SERVING ANOTHER APPLIANCE

The complete venting system consists of several components: chimney connector, wall thimble, wall pass-through, chimney, and liner. It is *absolutely necessary* that if you install all of these components, they must remain within the clearances to combustibles discussed earlier to install your stove safely. To protect against the possibility of a house fire, you *must properly install and constantly maintain the venting system*. Upon inspection, immediately replace rusted, cracked, or broken components.

- 🔥 The *chimney connector* is the stovepipe from the woodstove to the chimney. The chimney connector stove pipe must be 6" (152 mm) diameter, 24 MSG or 25 MSG blued steel connector pipe. *Do not use aluminum or galvanized steel pipe* - they cannot withstand the extreme temperatures of a wood fire.
- 🔥 Double wall connector (close clearance pipe) which must be used with a listed factory-built "Type HT" chimney and may also be used with a masonry chimney to reduce clearances, is available from several manufacturers, your dealer can help you choose. Some air insulated connector pipe models available are: Simpson Dura Vent DVL, Metalbestos DS. The following models have acceptable close clearance connector pipe for the Deva 100; Security, GSW and Ameritec.
- 🔥 Chimney connector shall not pass through floor or ceiling, nor any attic or roof space, closet or similar concealed space. Where passage through a wall or partition of combustible construction is desired, the installation shall conform to NFPA 211 or CAN/CSA - B365.
- 🔥 It is very important to follow minimum clearances for chimney connectors to combustibles such as walls and ceilings when installing the stove near non-combustible surfaces. Typical chimney connector clearances are outlined below. The single wall clearances are generic; the Double wall clearances are for Simpson Dura Vent DVL,

CHECK THE SPECIFICATIONS FROM THE MANUFACTURER OF YOUR CONNECTOR.

- 🔥 A *thimble* is a manufactured (or site-constructed) device installed in combustible walls through which the chimney connector passes to the chimney. It keeps the walls from igniting. You must use a wall thimble when installing a chimney connector through a combustible wall to the chimney.
- 🔥 A *wall pass-through* (or chimney support package) also keeps the walls from igniting. You must use one when connecting through a wall or ceiling to a prefabricated chimney.
- 🔥 Only install this stove to a *lined masonry chimney* or an approved high temperature *prefabricated residential* type building heating appliance chimney. *Do not* connect this stove to a chimney serving another appliance; you will compromise the safe operation of both the wood cook stove and the connected appliance.
- 🔥 **WARNING: DO NOT CONNECT THIS APPLIANCE TO ANY AIR DISTRIBUTION DUCT OR SYSTEM.**
- 🔥 A *liner* is the UL 1777 or ULC S635 (for factory built fireplace or masonry) chimney.

You must connect your stove to a chimney comparable to those recommended in this manual. *Do not use stovepipe as a chimney or liner system*. Use stovepipe for freestanding installations only to connect the stove to a proper chimney.

INSTALLING A VENTING SYSTEM

Stovepipe sections must be attached to the stove and to each other with the crimped end toward the stove. If creosote builds up, this allows the creosote to run into the stove and not the outside of the stovepipe and onto the stove.

Secure all venting joints. Attach the stovepipe to the stove's flue collar, with at least three sheet metal screws. Install #10 x 1/2" (3 mm x 13 mm) sheet metal screws into the holes pre-drilled in the flue collar.

You can simplify connecting stovepipe by using additional accessories such as telescoping pipes, slip-connectors or clean-out tees. These accessories ease the inspection of your chimney, as well as allowing you to easily dismantle the stovepipe (without moving the cook stove) when you periodically inspect the stovepipe connection and chimney.

Install the stove as close as practical to the chimney, while maintaining all proper clearances. Install stovepipe that is as short and as straight as possible. Horizontal runs of stovepipe should always rise away from the stove a minimum of 1/4" per foot (21mm/m).

Long runs of stovepipe to increase heat dispersal are not recommended. Using longer lengths of stovepipe or more connecting elbows than necessary increase the chances of draft resistance and the accumulation of creosote buildup.

In general, you do not need to install a stovepipe damper with the Deva. Some installations, however, could benefit from a stovepipe damper, such as a tall chimney which can create a higher than normal draft. In such cases, a damper can help regulate the draft. The Deva requires a draft between 0.06" w.c. and 0.1" w.c. For drafts above 0.1" w.c., install a stovepipe damper. Locate your local Hearthstone dealer to purchase a draft gauge to measure the draft of your chimney and flue system.

Remember, the NFPA has recommended, minimum clearances for chimney connectors to combustibles such as walls and ceilings.

CONNECTING YOUR WOOD-FIRED COOK STOVE

You can install your Deva 100 to a prefabricated metal chimney or a masonry chimney.

CONNECTING TO A PREFABRICATED

METAL CHIMNEY

When connecting the Deva 100 to a prefabricated metal chimney, you must follow, precisely, the manufacturer's installation instructions. Use only Type HT (2100 deg. F), prefabricated metal chimneys listed per UL 103 or ULC S629 standards.

WARNING:
DO NOT CONNECT THE STOVE TO A CHIMNEY FLUE SERVING ANOTHER APPLIANCE.

Make sure the size of the chimney's flue is appropriate for the Deva 100. The Deva 100 requires a 6" (152 mm) inside diameter flue for new installations. A 6" diameter flue provides adequate draft and performance. You can use an 8" (203 mm) diameter existing flue with a reducer. An oversized flue contributes to creosote accumulation. (In this case, bigger is NOT better.)

When purchasing a prefabricated chimney to install with your stove, be sure to also purchase from the same manufacturer, the wall pass-through (or ceiling support package), "T" section package, fire-stops (when needed), insulation shield, roof flashing, chimney cap, and any other needed accessories. Follow the manufacturer's instructions when installing the chimney and accessories. In addition, be sure to maintain all manufacturers' recommendations for the proper clearances to the chimney.

There are two ways to install a prefabricated metal chimney:

- An *interior* installation where the chimney passes inside the residence through the ceiling and roof.
- An *exterior* installation where the chimney passes through the wall behind the stove then up the outside of the residence.

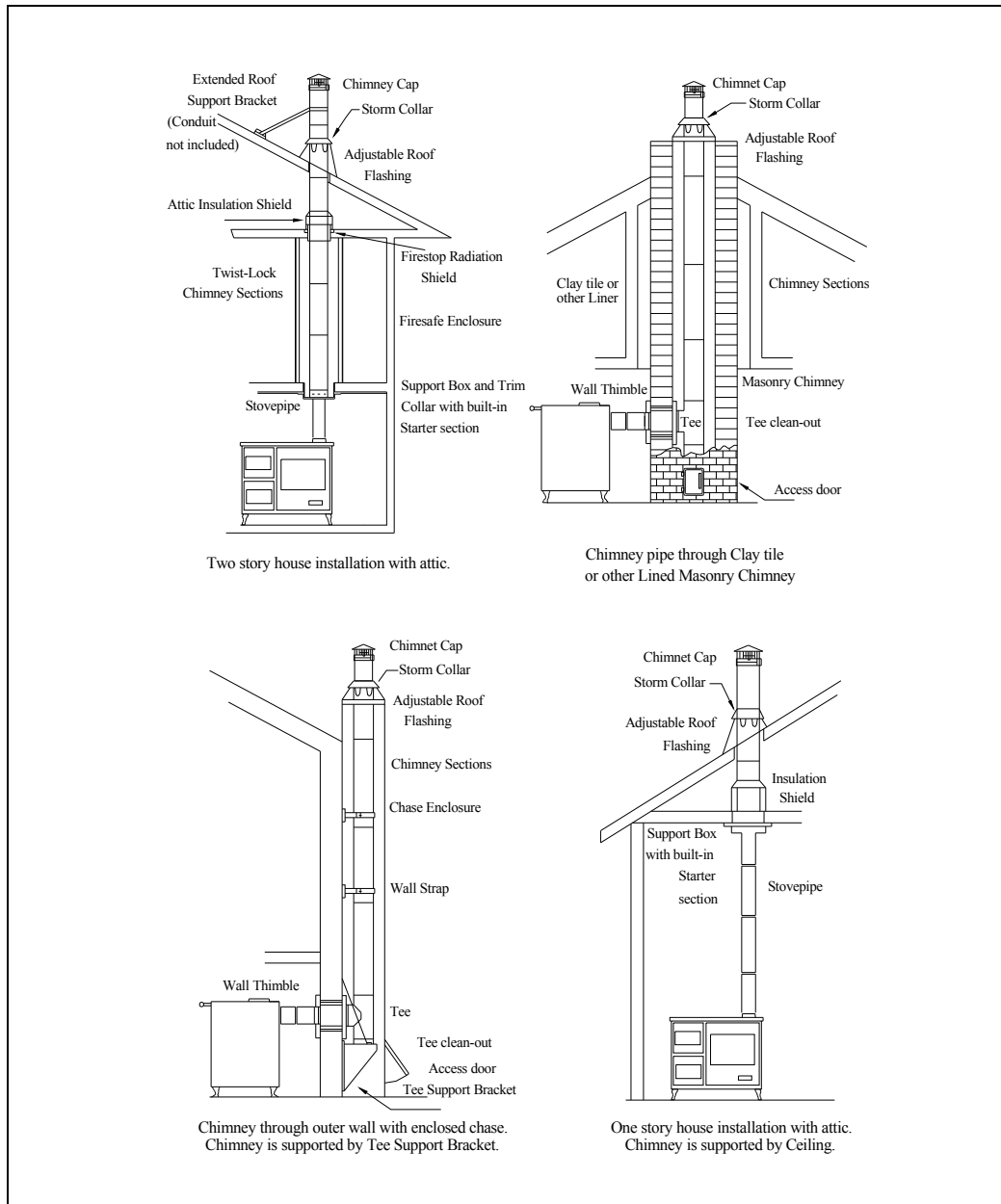

Whenever possible, choose an interior chimney. An interior chimney heats up more quickly and retains its heat; thus promotes a better draft and discourages the formation of creosote. An exterior chimney does not benefit from the warmth of being surrounded by the building, so it typically operates at lower flue temperatures than an interior chimney. An exterior chimney's draft is not as strong and may experience increased creosote accumulation.

REVERSAL OF THE FLUE COLLAR

In order to reverse the flue collar to vent the stove straight out the back, follow these simple steps;

- 1) Using a 10mm wrench, or socket. Locate and remove the four bolts holding the flue collar in place. Once all four bolts are removed pull the collar away from the stove. Inspect the gasket, ensuring it is in place, and in working order.

- 2) Locate and remove the four bolts that hold the block-off plate on the back of the stove. Remove the plate.
- 3) Place the flue collar on the back of the stove over the rear flue exit with the gasket side towards the stove. Rotate the collar so the 3 chimney connector screws are easiest to access when necessary to install later. Replace the four bolts using the 10mm wrench.
- 4) Place the cover plate over the flue exit on the top of the stove, using the same four bolts that were removed.

CONNECTION TO A MASONRY CHIMNEY

Consider two primary elements when connecting your stove to a masonry chimney: the chimney itself and the thimble where the stovepipe connects to the chimney. Use only Code approved masonry chimneys with a flue liner.

Before connecting to a masonry chimney, hire a professional to examine the chimney for cracks, loose mortar, and other signs of deterioration and blockage. If the chimney needs repair, complete the project before installing and using your stove. Do not install your stove until the chimney is safe for use.

Make sure the chimney's cleanout is complete and working properly. To avoid a loss of draft, the cleanout must close off completely. If allowed to cool, your stove will perform poorly and creosote will build up in the chimney.

Make sure the size of the chimney's flue is appropriate for this stove and that it is not too large. Use a masonry chimney with an 8" x 8" (203 mm x 203 mm) tile size for best results. An oversized flue will contribute to the accumulation of creosote.

Use the following checklist to ensure that your masonry chimney meets these minimum requirements:

Chimney wall construction:

- ❑ Brick or modular block at least 4" (102 mm) thick.
- ❑ A rubble or stone wall at least 12" (305 mm) thick.

Flue liner:

- ❑ Minimum thickness of 5/8" (16 mm).
- ❑ Installed with refractory mortar.
- ❑ At least 1" (25 mm) air space.
- ❑ An equivalent flue liner must be a listed chimney liner system meeting type HT requirements or other approved material.

Interior chimney requirements:

- ❑ At least 2" (51 mm) clearance to combustible structure
- ❑ Fire stops must be installed at the spaces where the chimney passes through floors and/or ceiling.
- ❑ Insulation must be 2" (51 mm) from the chimney.

Exterior chimney requirements:

- ❑ At least 1" (25 mm) clearance to combustible structure.

Chimney height requirements: (See Illustration)

- ❑ At least 3 feet (0.9 m) higher than the highest part of the roof opening through which it passes.
- ❑ At least 2 feet (0.6 m) higher than any part of the roof within 10 feet (3 m) measured horizontally from the top of the chimney.

This stove requires a minimum chimney height of 13 feet (4 m). The maximum allowable chimney height is 30 feet (9 m).

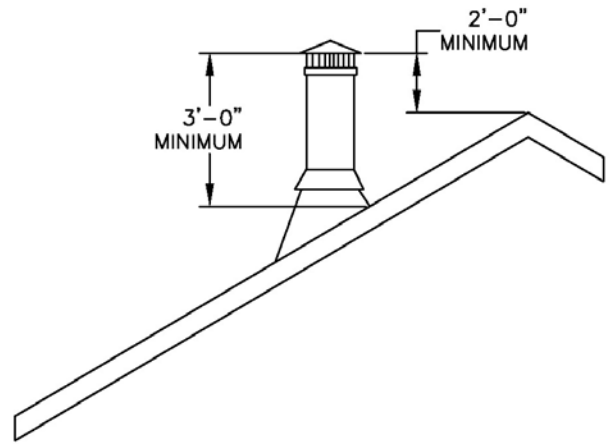
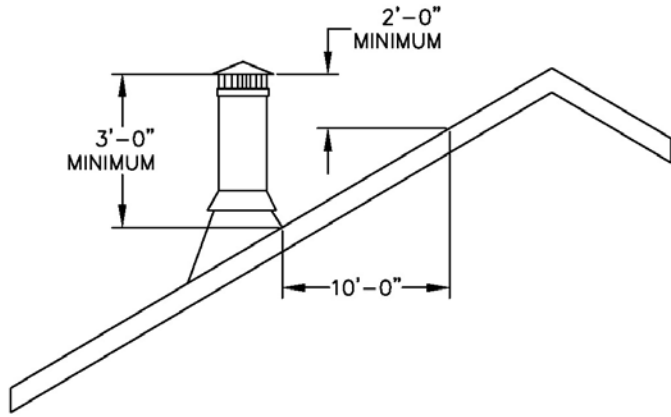

Operation

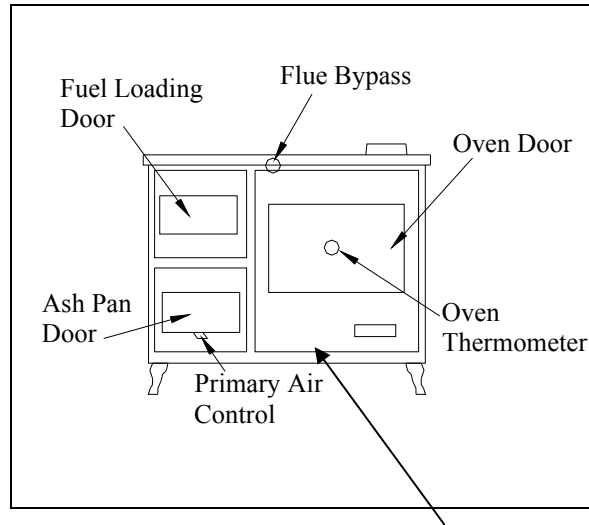

Figure 2 - Controls and Features OVEN

WARNING:
DO NOT INSTALL IN A SLEEPING ROOM

WARNING:
HOT WHILE IN OPERATION. KEEP CHILDREN, CLOTHING AND FURNITURE AWAY. CONTACT MAY CAUSE SKIN BURNS.

Please read this entire chapter before lighting your first fire. It explains the controls and features of your wood stove, how to choose firewood, and how to use your stove on a daily basis.

CONTROLS AND FEATURES

Before lighting any fires, become familiar with the location and operation of your stove's controls and features and learn how to use them. For your own safety, do not modify these features in any way.

FLUE BYPASS SYSTEM: When starting a fire in a cold Deva 100 you will need to use the flue

bypass system. This is the handle at the top center of your stove that pushes and pulls in and out. To open the bypass, pull the handle out. This opens a "bypass" channel that allows the hot gases to heat up the chimney quicker. This bypass allows for a direct outlet of the flue gases and smoke. With the bypass closed the gases follow the normal route around the oven and then out. You should keep the bypass open until your flue has established a draft. Once a draft has been established push the bypass closed. This will ensure the most efficient use of your Deva.

*Burning the Deva 100 with the bypass open will not allow the oven to reach maximum temperatures.

FUEL LOADING DOOR HANDLE: The fuel loading door allows you to load wood into your stove. To open the door, lift the handle to the 9 o'clock position and pull the door. To latch the door, lower the handle to the 6 o'clock position. Pull gently on the door to make sure it is properly latched.

PRIMARY AIR CONTROL: This feature is located on the lower portion of the ash door of the stove. The primary air control allows you to regulate the amount of air entering the firebox. Generally speaking, the more air allowed into the firebox, the faster and hotter the rate of burn; conversely, less air creates a slower burn. Push the lever to the left to open the primary air control; push the lever to the right of the stove to close the primary air control.

ASH PAN: The ash pan is located under the firebox door. The ash pan collects burned ash from a fire and allows you to conveniently remove the ash from your wood stove. The ash pan is easy to remove. Sift the ashes across the grate and into the ash pan, and then rotate the ash door handle to the 9:00 o'clock and pull to open. Remove the ash pan by grabbing the handle and sliding it out carefully. After you have disposed of the ashes, push the ash pan all the way into the stove and close the ash door by turning the handle to the 6 o'clock position.

Remove ashes when the stove is cold. If the ash pan is warm, use protective fireplace gloves. Exercise extreme caution when handling, storing or disposing of ashes.

CHOOSING FIREWOOD

Your Deva 100 cook stove is designed to only burn firewood-also known as cordwood.

CAUTION:
DO NOT USE CHEMICALS OR FLAMMABLE FLUIDS SUCH AS GASOLINE, NAPHTHA, KEROSENE, CHARCOAL LIGHTER FLUID OR ENGINE OIL TO START A FIRE. DO NOT USE CHARCOAL, PELLETS, COAL, ARTIFICIAL LOGS OR ANY OTHER MATERIALS AS FUEL; THEY ARE NOT SAFE. DO NOT BURN GARBAGE.

The quality of your firewood affects heat output, duration of burn and performance of your stove. Softwoods generally burn hotter and faster,

while hardwoods burn longer and produce more coals. Density and moisture content are two critical factors to consider when purchasing wood for your stove.

The following is a list of wood species and their relative BTU (British Thermal Unit) content. The higher the BTU the longer the burn. Firewood with higher BTUs is generally considered more ideal for a wood stove.

HIGH: Apple, Black Birch, Hickory, Locust, White Oak, Black Beech, Mesquite

MEDIUM HIGH: White Ash, Beech, Yellow Birch, Sugar Maple, Red Oak

MEDIUM LOW: Black Ash, White Birch, Grey Birch, Elm, Norway Pine, Pitch Pine, Black Cherry, Soft Maple, Tamarack

LOW: White Pine, White Cedar, Balsam Fir, Spruce, Aspen, Basswood, Butternut, Hemlock

Moisture content also plays a key role in the performance of your stove. Wood freshly cut from a living tree (green wood) contains a great deal of moisture. As you might expect, green wood has difficulty burning and should be seasoned before using it in your cook stove. To properly season green wood, it should be split, stacked and allowed to air dry for a period of one year.

Stack the firewood on skids or blocks to keep it off the ground, cover only the top of the stack. Plastic or tarps that cover the sides of the woodpile trap moisture and prevent the wood from drying. As for stacking, an old Vermonter said, "The spaces between the logs should be large enough for a mouse to get through, but not for the cat that's chasing it."

Firewood should not be stored within the stove's specified clearances to combustible materials.

BUILDING YOUR FIRST FIRE

Once you understand the controls of your wood stove and have chosen the appropriate firewood, you are ready to start a fire.

When you light your first fires, the wood stove will emit some smoke and fumes. This is normal “off-gassing” of the paints and oils used when manufacturing the wood stove. If you find it necessary, open a few windows to vent your room. The smoke and fumes will usually subside after 10 to 20 minutes of operation. The odor and smoke will end once the stove is “cured”.

The first fires may produce other odors from impurities that exist in the area immediately surrounding the stove. Some of these impurities can be cleaning solvents, paint solvents, cigarettes, smoke, pet hair, dust, adhesives, a new carpet, and new textiles. These odors will dissipate over time. You can alleviate these odors by opening a few windows or otherwise creating additional ventilation around your stove.

BUILDING A FIRE

1. Open the door and place five or six double sheets of tightly twisted newspaper in the center of the firebox. Arrange kindling in a crisscross pattern over the newspaper. Kindling should be approximately ten pieces, 1/2" (13 mm) in diameter and 10" to 17" (254 to 431 mm) long.
2. Open the flue bypass system by pulling the handle out completely. (as described on page 17)
3. Fully open the primary air control by pushing the lever toward the left of the stove.
4. Light the paper under the kindling. Leave the door slightly ajar momentarily until the kindling has started to burn and draft begins to pull.

5. Close the door and allow the fire to burn.
6. Once the kindling is burning, open the door and add logs, small at first, to build the fire up. Otherwise, keep the fuel loading door and ash door closed while the stove is in use.

Do not open the fuel loading door with the bypass closed!

7. Close the bypass system by pushing the handle all the way in.
8. Once the fire is burning well, use the primary air control to regulate the desired rate of burn. Pushing the lever to the left of the stove opens the PRIMARY AIR CONTROL for a high rate of burn or pushing it to the right of the stove for a low rate of burn.
9. The flue bypass is used to control the cook top and oven temperature.

Note: When opening the door to reload or re-arrange logs, it is advisable to open the door just a crack, pause for a moment, then open the door completely. This procedure will allow the firebox to clear of smoke before the door is opened fully. **You must open the flue bypass system prior to opening your fuel loading door.** Also, reloading on a bed of hot, red coals reduces smoking time and will bring fresh fuel up to a high temperature rapidly.

BURN RATE

HIGH BURN: Fully load the firebox with wood on a bed of hot coals or on an actively flaming fire and fully open the primary air control. A high burn rate is recommended once or twice a day to fully heat the stovepipe and chimney, which will help minimize creosote accumulation.

MEDIUM BURN: Set the primary air control to a mid-range setting appropriate for the heating needs of the area being heated. A medium burn rate should be the typical setting and is preferable if the stove is to be left unattended.

LOW BURN: Close the primary air control for a low burn rate. A low burn rate over extended periods of time is not advisable as it may promote the accumulation of creosote. The venting system should be inspected frequently if low burn rates are maintained consistently.

OVER-FIRE CAUTION

Over-firing means the stove is operating at temperatures above the recommended temperatures outlined above in the *BURN RATE* section. Over-firing should be carefully avoided since it will cause damage to the stove. Symptoms of over-firing include short burn times, a roaring sound in the stove or stovepipe, and discoloration of the stovepipe.

Over-firing can be caused by excessive draft, inappropriate fuel, and operator error. Correct an over-fire situation as follows:

EXCESSIVE DRAFT: Contact your dealer to have a draft reading taken. Any draft in excess of 0.1 wc requires a damper in the stovepipe. Some installations may require more than one damper.

INAPPROPRIATE FUEL: Do not burn coal, kiln dried lumber, wax logs or anything other than natural cordwood.

OPERATOR ERROR: Make sure all the gaskets are in good condition. Replace worn out or compressed gaskets. Do not burn the stove with the fuel loading door, or ash pan door in the open position.

Monitoring the temperature is the best way to determine that the stove is over-firing. If you

suspect that your stove is over-firing, contact your dealer immediately. Damage done by over-firing is not covered by your warranty. Results of over-firing can include: warped or burned out internal parts, cracked refractory, discolored or warped external parts, and damaged enamel.

NOTE: ANY SYMPTOMS OF OVER-FIRING WILL VOID YOUR WARRANTY!!

REMOVAL AND DISPOSAL OF ASHES

Ashes should be removed when the stove is cold. Use protective fireplace gloves when the pan is warm. Exercise extreme caution when handling, storing or disposing of ashes.

To remove ashes from the firebox, sift the ashes across the ash grate using a poker or other suitable implement. Remove the ashes by pulling the handle on the ash pan and sliding it carefully out. Dump the ashes as described below. Re-insert the ash pan by pushing it in all the way. Be sure that the ash pan has been pushed firmly into place. Alternately, the ashes can be removed with a shovel through the fuel loading door.

Ashes should be dumped from the ash drawer into a metal container with a tight fitting lid. Do not place any other items or trash into the metal container. Replace the lid onto the container and allow the ashes to cool. Do not place the ash disposal container on a combustible surface or vinyl flooring, as the container will be **hot!**

Pending disposal, place the closed ash container on a noncombustible floor or on the ground, well away from all combustible materials. Ashes should be retained in the closed container until all cinders have thoroughly cooled.

Ashes should NEVER be placed in wooden or plastic containers, or in paper or plastic bags, no matter how long the fire has been out. Coals within a bed of ashes can remain hot for several days once removed from the firebox.

MAINTENANCE

CREOSOTE FORMATION AND NEED FOR REMOVAL

When wood is burned slowly, it produces tar and other organic vapors, which combine with expelled moisture to form creosote. These creosote vapors condense in the relatively cool chimney flue of a slow-burning fire. As a result, creosote residue accumulates on the flue lining. When ignited, this creosote makes an extremely hot fire, which may damage the chimney or even destroy the house.

To prevent the buildup of creosote:

1. Burn the stove with the primary air control fully open and the flue bypass open for 30 minutes daily to burn out creosote deposits from within the stove and the venting system.
2. After reloading with wood, burn the stove with the primary air control fully open for 20 to 30 minutes. This manner of operation ensures early engagement of the secondary combustion system which, when engaged, minimizes creosote buildup in the chimney.

The stovepipe connector and chimney should be inspected regularly during the heating season to determine if a creosote build-up has occurred. If a creosote residue greater than 1/4" (6 mm) has accumulated, it should be removed to reduce the risk of a chimney fire.

The venting system must be inspected at the stove connection *and* at the chimney top. Cooler surfaces tend to build creosote deposits quicker, so it is important to check the chimney at the top (where it is coolest) as well as from the bottom near the stove.

Accumulated creosote should be removed with a cleaning brush specifically designed for the type of chimney in use. A certified chimney sweep should be used to perform this service. Contact your dealer for the name of a certified

chimney sweep in your area (your dealer may be a certified sweep!).

GASKETS

Gasket material should normally be replaced every two to three seasons, depending on stove use. If the door seal is loose, a new gasket will assure a tight seal and improved stove performance. Contact your dealer for a gasket kit, which includes instructions, and gaskets for your stove.

To replace the fuel loading door gasket, first remove the old gaskets with a utility or putty knife. Clean all gasket channels with a wire brush. Apply gasket cement to the channels and push the new gasket into place without stretching the gasket material. The door should be shut immediately to fully press the gasket into place and assure a positive seal.

We require the use of the following gaskets:

FUEL LOADING DOOR: 40" (102 cm)
Length, 1/4" Diameter, Low Density Black Rope

FUEL LOADING GLASS: 40" (102 cm)
Length, 3/4" adhesive backed flat tape

ASH PAN DOOR: 40" (102 cm)
Length, 1/4" Diameter, Low Density, Black Rope

REVERSIBLE FLUE: 28" (71 mm) Length, 1/4" Diameter, Low Density, Black Rope

GLASS

Do not operate the stove with a broken door glass. Do not abuse the fuel loading door by striking or slamming it.

When necessary, the glass can be cleaned with low alkaline content commercial stove glass cleaners, which are available from your local dealer. Never attempt to clean the glass while the fire is burning or the glass is hot. Following the instructions provided with the cleaner can clean most deposits. To clean heavier deposits, remove the door from the cook stove and lay the it face down on a workbench or

table. Apply the cleaner to the glass and allow it to set for a few minutes. By laying the door flat, it will allow the cleaner to penetrate rather than running off the surface of the glass. Wipe the cleaner off with a soft cloth.

Important: scratching or etching the glass will weaken the integrity of the glass. Do not use a razor blade, steel wool, or any other abrasive material to clean the glass. Use low alkaline content cleaners only.

The fuel loading door glass is a ceramic, shock-resistant glass, made specifically for use in wood-burning stoves. Do not use any replacement glass other than the ceramic glass manufactured and supplied for use in this cook stove. Replacement glass is available through your local dealer.

The fuel loading door glass should be replaced immediately if broken. Contact your local dealer for replacement glass, which is accompanied with instructions and everything needed for the repair. If you replace the glass yourself, wear work gloves and safety glasses.

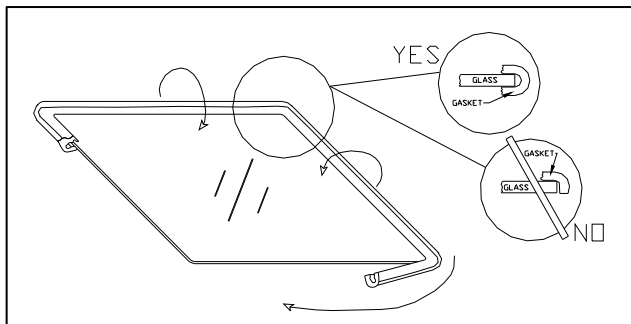

The procedure for the fuel loading door glass and glass gasket replacement is as follows:

1. Remove the top hinge straight up and away from the stove.
2. Remove the door by pulling it up and away from the stove.
2. Place the door face down on a flat, smooth surface.
3. Apply penetrating oil to the 2 screws in the retention frame. Remove the 2 screws. Separate the cast iron window frame from the door.

4. Carefully lift the damaged glass from the door and discard.
5. Peel the paper backing from the tape gasket. Apply the new gasket to the new glass as illustrated above.
6. Place the gasketed glass onto the door.
7. Screw the window frame back on the door.
8. Install the door.

MAINTENANCE OF THE GLASS COOK TOP

Be sure utensils have no rough spots to scratch the surface. Be sure the surface is clean before the fire is started. Avoid spills and boil-overs by turning down heat to lowest possible setting for cooking task, and by using a large enough pan. Wipe up wet spots promptly, being careful to avoid steam burns. Don't cook with foil on the glass cook top. It could be damaged by foil melting onto it. Cover pans to prevent spatters.

CLEANING OF THE GLASS COOK TOP

Special care should be taken when removing hot substances. Turn off all surface units affected by the spillover and remove the hot pans. Wearing an oven mitt to hold the scraper, scrape the spill to a cool area of the cook top and use a paper towel to remove any excess. Do not continue to use the soiled area until all the spillover has been removed. A couple of recommended cook top cleaners are:

- Weiman Cooktop Cleaning Creme
- Cera Care
- Hopes Cooktop Cleaning Creme
- Cerama Bryte™

CAST IRON

Exterior cast iron parts are porcelainized with an enamel finish. Use a damp sponge to wipe clean. Dry the cast iron thoroughly to prevent rusting.

Enamel castings can be cleaned with a standard glass cleaner. With time and use, a very fine, subtle network of crazed lines may appear seemingly beneath the surface of the enamel. Crazing is a natural predictable process and does not represent a flaw.

TROUBLESHOOTING

Most are correctable and generally require only a minor adjustment of the stove, installation, or operating technique. In cases where weather conditions dramatically affect stove performance, the problems are typically temporary and solve themselves once the weather changes.

One common cause of poor performance is an oversized chimney flue. Oversized chimney flues result in decreased pressure, which prevents the smoke from rising out the chimney. Oversized flues are also more difficult to heat effectively, especially when burning a high efficiency stove. Cool flue temperatures inhibit the establishment of a strong draft (and encourage the accumulation of creosote). The lack of a strong draft will cause the fire to die down and may even force the smoke to pour into the room.

If your chimney is the proper size and a strong draft is not easily established, there is the possibility of the chimney being too cold. Again, hot chimneys promote a stronger draft.

Other draft guidelines are as follows:

AN "AIRTIGHT" HOUSE: If your home is super-insulated or especially well sealed, the (infiltration) air supply to the interior of the house may be inadequate. This phenomenon of air starvation within the building can be exacerbated if exhaust fans, such as clothes dryers, bathroom fans or cook-stove exhaust fans, are in operation within the home. The need for additional air may be accommodated

by opening a window to provide the adequate air.

TALL TREES OR BUILDINGS: These obstructions, when located in proximity to the top of the chimney can cause chronic or occasional downdrafts. When selecting a site for a new chimney, take care to consider the placement of other objects in the vicinity of the proposed chimney location.

WIND VELOCITY: Generally, the stronger and steadier a wind, the stronger (better) the draft. However, "gusty" wind conditions may cause erratic downdrafts.

BAROMETRIC PRESSURE: Chimney drafts are typically sluggish on balmy, wet or muggy days. This is a weather-related phenomenon, which generally is self-correcting as the weather changes.

BRISKNESS OF FIRE: The hotter the fire in your stove, the hotter your chimney and, therefore, the stronger the draft.

BREAKS IN THE VENTING SYSTEM: An unsealed clean-out door at the bottom of the chimney, leaky stovepipe joints, a poor stovepipe-to-thimble connection, or a leaky chimney may cause inadequate draft.

SEASONAL FACTORS: Early fall and late spring are generally difficult seasons in which to establish proper drafts. The colder the outside air (relative to room temperatures), the stronger the draft.

TROUBLESHOOTING GUIDE

PROBLEM	POSSIBLE CAUSE	SOLUTIONS
STOVE SMOKES	<p>Operating Technique</p> <p>Cold Chimney Blocked Chimney</p> <p>Oversized Chimney Undersized Chimney Chimney Too Short Air Infiltration Into The Chimney More Than One Appliance Connected to the Flue</p>	<p>Fully open the primary air control one minute before opening doors.</p> <p>Fully open the flue bypass system</p> <p>Preheat the chimney when first starting a fire.</p> <p>Examine the chimney and stovepipe for blockage or creosote accumulations.</p> <p>Reline the chimney to the appropriate diameter</p> <p>Install a draft inducer or replace the chimney.</p> <p>Lengthen the chimney.</p> <p>Seal chimney connections and openings in clean-out doors.</p> <p>Disconnect all other appliances and seal openings.</p>
BACK-PUFFING OR GAS EXPLOSIONS	<p>Operating Technique</p> <p>Extra Low Burn Rate Chimney Down-draft Excessive Ash Build-up</p>	<p>Fully open the primary air control one minute before opening the door and keep it fully open for a few minutes after reloading.</p> <p>Burn the stove at a higher burn rate.</p> <p>Install a chimney cap.</p> <p>Empty ash pan more frequently.</p>
UNCONTROLLED OR SHORT BURN	<p>Unsealed or Open Door</p> <p>Excessive Draft</p> <p>Deteriorated Cement Seals Extra Long Chimney</p> <p>High Winds or Hilltop Location: Excessive Draft</p>	<p>Close the door tightly or replace the gaskets.</p> <p>Check the installation. Operate at LOW BURN. Install stovepipe damper.</p> <p>Reseal the stove with furnace cement.</p> <p>Shorten the chimney. Install stovepipe damper.</p> <p>Install a chimney cap.</p> <p>Draft in excess of 0.1 wc should be corrected with a stovepipe damper.</p> <p>Completely close the flue bypass system</p>
INSUFFICIENT HEAT	<p>Poor Quality or Green Wood Low Burn Rate Air Insulated Chimney</p> <p>Cold Exterior Chimney Leaky Stovepipe or Chimney Too Much Heat Loss From House</p>	<p>Use only air-dried wood, preferably dried <u>at least</u> one year.</p> <p>Operate the stove at a higher burn rate.</p> <p>Replace with a pre-fabricated insulated chimney system or a properly sized masonry chimney.</p> <p>Reline or insulate the chimney.</p> <p>Check the installation.</p> <p>Caulk windows, seal openings in home.</p>
INSUFFICIENT OVEN HEAT	<p>Fuel Bypass is open Oven door is not sealed properly</p>	<p>Push Flue Bypass in to close the bypass.</p> <p>Check the seal and repair if necessary</p>
BLISTERING OF ENAMEL CASTING	<p>Operating Technique</p> <p>Excessive Draft</p>	<p>Do not over-fire the stove. Monitor stove temperatures. Use seasoned wood only.</p> <p>Check the DRAFT. A damper may be required. Operate the stove at a LOW BURN range.</p>

REPLACEMENT PARTS & OPTIONAL ACCESSORIES

PART NUMBER:	DESCRIPTION:		PART NUMBER:	DESCRIPTION:
	GLASS			
3030-050	FUEL LOADING DOOR GLASS			MISC. COMPONENTS
3030-051	OVEN DOOR GLASS		91-59710	SIDE ASSEMBLY
91-58710	TOP GLASS ASSEMBLY		91-58711	OVEN DOOR ASSEMBLY
			91-58712	ASH DOOR ASSEMBLY
			91-58713	FUEL LOADING DOOR ASSEMBLY
	HANDLES		2650-016	FLUE COLLAR
91-71710	OVEN DOOR HANDLE		5170-005	HANDLE BAR SUPPORT
91-71711	FIREBOX DOOR HANDLE		5170-007	HANDLE BAR
91-71712	ASH DOOR HANDLE		5170-010	REFRACTORY STONE BRACKET
				REFRACTORY STONE
			3060-432	REFRACTORY BASE
			3060-433	LEFT REFRACTORY
			3060-434	RIGHT REFRACTORY

SAFETY LABEL

CONTACT YOUR LOCAL BUILDING AND INSTALLATION OFFICIALS ABOUT RESTRICTIONS AND INSPECTION IN YOUR AREA

Listed Room Heater, Solid Fuel Type



WN04380
Intertek Testing
Services NA, inc.

SERIAL #
MODEL NAME: DEVA 8220
TESTED TO: UL 1482, ULC S627
TYPE OF FUEL: Solid Wood Only

Manufactured by:

Industrias Hergom S.A
Apdo. de Correos, 208 de Santander
Santander, Spain 390 80



for 317 Stafford Ave.
Morrisville VT 05661
USA

"PREVENT HOUSE FIRES"

Install and use only in accordance with manufacturer's installation instructions and your local building codes.

WARNINGS:

- Do not operate with doors open.
- Do not obstruct space under heater
- Do not use grate or elevate fire. Build wood fire directly on hearth.
- Do not over-fire. If the heater or chimney connector glows, you are over-firing.

CAUTION: Special methods are required when passing chimney through a wall or ceiling, refer to local building codes. Do not connect this unit to a chimney flue serving another appliance.

NOTE: Replace firebox glass only with 4mm CERAMIC glass

Clearance to Combustible Materials*

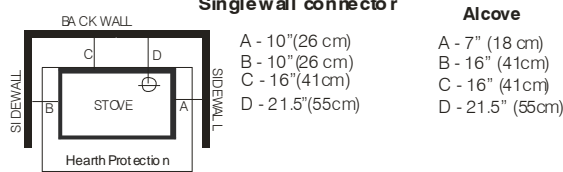

When installed on a combustible floor, minimal hearth protection must be a non-combustible material with an R-value of at least 0.89 underneath the cookstove that extends 16" US (46cm CAN) beyond the fuel loading door and 8" US (20cm CAN) beyond each side of the cookstove. If using the rear exit of the stove, the floor protection must extend under the flue connector and extend 2" beyond each side of the pipe.

* Refer to the Installation Manual for additional clearance information.

VENT REQUIREMENTS:

6 inch diameter, single wall, minimum 24 MSG black or 25 MSG blue steel connector with listed factory-built Type HT chimney or lined masonry chimney.



CAUTION: HOT WHILE IN OPERATION. DO NOT TOUCH. KEEP CHILDREN, CLOTHING AND FURNITURE AWAY. CONTACT MAY CAUSE SKIN BURNS. SEE NAMEPLATE AND INSTRUCTIONS. INSPECT AND CLEAN CHIMNEY AND CONNECTOR FREQUENTLY. UNDER CERTAIN CONDITIONS OF USE, CREOSOTE BUILDUP MAY OCCUR RAPIDLY.

U.S. ENVIRONMENTAL PROTECTION AGENCY
Certified to comply with July 1, 1990 particulate emissions standards



DO NOT REMOVE OR COVER THIS LABEL

3300-619 Rev A

WARRANTY REGISTRATION

The Original Purchaser may complete the warranty registration process on our website: www.hearthstovestoves.com, or send a completed and signed Warranty Registration Form, which is enclosed in the Cook stove warranty packet, to the following address:

Hearthstone Quality Home Heating Products, Inc.
Warranty Department
317 Stafford Ave
Morrisville, VT 05661

NOTE: SENDING IN THE SIGNED WARRANTY REGISTRATION FORM IS NOT A CONDITION OF WARRANTY COVERAGE OR HEARTHSTONE'S PERFORMANCE.