

# INSTALLATION AND OPERATION MANUAL

## OSBURN 2000

(OB02010 model)



**BEYOND**  
fire

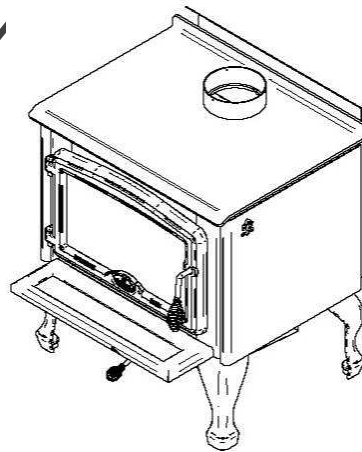
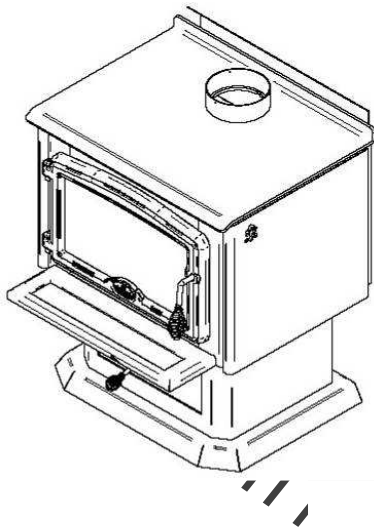

US ENVIRONMENTAL  
PROTECTION AGENCY PHASE  
II CERTIFIED WOOD STOVE  
Safety tested according to  
ULC S627, UL 737 and UL 1482  
Standards by  
an accredited laboratory



[www.osburn-mfg.com](http://www.osburn-mfg.com)

Stove Builder International Inc.

250, rue de Copenhague, St-Augustin-de-Desmaures (Quebec) Canada G3A 2H3

After-sale service: 418-908-8002 E-mail: tech@sbi-international.com



*This manual is available for free download on the manufacturer's web site. It is a copyrighted document. Re-sale is strictly prohibited. The manufacturer may update this manual from time to time and cannot be responsible for problems, injuries, or damages arising out of the use of information contained in any manual obtained from unauthorized sources.*

**READ AND KEEP THIS MANUAL FOR REFERENCE**

## THANK YOU FOR CHOOSING THIS OSBURN WOOD STOVE

As one of North America's largest and most respected wood stove and fireplace manufacturers, Stove Builder International takes pride in the quality and performance of all its products. We want to help you get maximum satisfaction as you use this product.

In the pages that follow you will find general advice on wood heating, detailed instructions for safe and effective installation, and guidance on how to get the best performance from this stove as you build and maintain fires, and maintain your wood heating system.

We recommend that our wood burning hearth products be installed and serviced by professionals who are certified in the United States by NFI (National Fireplace Institute®) or in Canada by WETT (Wood Energy Technology Transfer) or in Quebec by APC (Association des Professionnels du Chauffage).

Congratulations on making a wise purchase.

**When this stove is not properly installed, a house fire may result. To reduce the risk of fire, follow the installation instructions. Contact local building or fire officials about restrictions and installation inspection requirements in your area.**

**Please read this entire manual before you install and use your new stove. Failure to follow instructions may result in property damage, bodily injury, or even death. It is important that you follow the installations guidelines exactly.**

**You may need to obtain a building permit for the installation of this stove and the chimney that it is connected to. Consult your municipal building department or fire department before installation to determine the need to obtain one. We recommend that you also inform your home insurance company to find out if the installation will affect your policy.**

### REGISTER YOUR WARRANTY ONLINE

To receive full warranty coverage, you will need to show evidence of the date you purchased your stove. Keep your sales invoice. We also recommend that you register your warranty online at:

<http://www.osburn-mfg.com/warranty-registration.aspx>

Registering your warranty online will help us to quickly track the information we need about your stove.

## Table of content

|  |           |
|--|-----------|
| <b>PART A - OPERATION AND MAINTENANCE .....</b>                      | <b>5</b>  |
| <b>1 Safety Information .....</b>                                    | <b>5</b>  |
| 1.1 Summary of Operation and Maintenance Cautions and Warnings ..... | 5         |
| <b>2 General Information on Osburn 2000 (OB02010) .....</b>          | <b>6</b>  |
| 2.1 Appliance performance <sup>(1)</sup> .....                       | 6         |
| 2.2 General Features .....   | 7         |
| 2.3 Zone Heating and How to Make it Work for You .....               | 10        |
| 2.4 The Benefits of Low Emissions and High Efficiency .....          | 10        |
| 2.5 The SBI Commitment to You and the Environment .....              | 11        |
| 2.5.1 What is Your New Stove Made Of? .....                          | 11        |
| <b>3 Fuel .....</b>  | <b>12</b> |
| 3.1 Materials That Should Not be Burned .....                        | 12        |
| 3.2 How to Prepare or Buy Good Firewood .....                        | 12        |
| 3.2.1 What is Good Firewood? .....                                   | 12        |
| 3.2.2 Tree Species .....   | 12        |
| 3.2.3 Log Length .....   | 13        |
| 3.2.4 Piece Size .....   | 13        |
| 3.2.5 How to Dry Firewood .....                                      | 14        |
| 3.2.6 Judging Firewood Moisture Content .....                        | 15        |
| 3.3 Manufactured Logs .....  | 15        |
| <b>4 Operating Your Stove .....</b>                                  | <b>16</b> |
| 4.1 The use of a fire screen .....                                   | 16        |
| 4.2 Your First Fires .....   | 16        |
| 4.3 Lighting Fires .....   | 16        |
| 4.3.1 Conventional Fire Starting .....                               | 17        |
| 4.3.2 The Top Down Fire .....  | 17        |
| 4.3.3 Two Parallel Logs .....  | 18        |
| 4.3.4 Using Fire Starters .....                                      | 18        |
| 4.4 Maintaining Wood Fires .....                                     | 18        |
| 4.4.1 General Advice .....   | 18        |
| 4.4.2 Ash Removal .....  | 19        |
| 4.4.3 Raking Charcoal .....  | 19        |
| 4.4.4 Firing Each New Load Hot .....                                 | 20        |
| 4.4.5 Turning Down the Air Supply .....                              | 20        |
| 4.4.6 Building Different Fires for Different Needs .....             | 21        |
| <b>5 Maintaining Your Wood Heating System .....</b>                  | <b>23</b> |
| 5.1 Stove Maintenance .....  | 23        |
| 5.1.1 Cleaning Door Glass .....                                      | 23        |
| 5.1.2 Door adjustment .....  | 24        |
| 5.1.3 Replacing the Door Gasket .....                                | 24        |

5.1.4 Replacing the Glass Gasket and/or the Glass ..... 25

5.1.5 Cleaning and Painting the Stove ..... 26

5.2 Chimney and Chimney Connector Maintenance ..... 26

5.2.1 Why Chimney Cleaning is Necessary ..... 26

5.2.2 How Often Should You Clean the Chimney? ..... 26

5.2.3 Cleaning the Chimney ..... 27

**PART B - INSTALLATION ..... 28**

**6 Safety Information ..... 28**

6.1 Summary of Installation Cautions and Warnings ..... 28

6.2 Regulations Covering Stove Installation ..... 28

**7 Clearances to Combustible Material ..... 29**

7.1 Location of the certification label ..... 29

7.2 Clearances to Walls and Ceiling ..... 30

7.3 Floor protector ..... 34

7.4 Reducing Wall and Ceiling Clearances Safely ..... 35

7.4.1 Shield Construction Rules ..... 35

7.4.2 Table of Clearance Reduction Percentages ..... 37

**8 The Venting System ..... 38**

8.1 General ..... 38

8.2 Suitable Chimneys ..... 38

8.2.1 Factory-built Metal Chimneys ..... 38

8.2.2 Factory-built Metal Chimneys in mobile homes ..... 39

8.2.3 Masonry Chimneys ..... 39

8.3 Minimum Chimney Height ..... 40

8.4 The Relationship Between the Chimney and the House ..... 40

8.4.1 Why inside chimneys are preferred ..... 40

8.4.2 Why the chimney should penetrate the highest heated space ..... 41

8.5 Supply of Combustion Air ..... 42

8.5.1 Combustion Air Supply in Mobile Homes ..... 42

8.5.2 Air Supply in Conventional Houses ..... 42

8.6 Installing the Chimney Connector ..... 43

8.6.1 Installation of Single Wall Chimney Connector ..... 43

**Appendix 1: Installing the Optional Legs or Pedestal ..... 46**

**Appendix 2: Installing the Optional Door Overlay ..... 50**

**Appendix 3: Installing the Decorative Panels ..... 51**

**Appendix 4: Installing the Optional Fresh Air Intake Kit (AC01316 / AC01336) ..... 52**

**Appendix 5: Installing the Optional Fire Screen (AC01315) ..... 54**

**Appendix 6: Installation and Use of the blower, and Use of the Optional Thermodisc ..... 55**

**Appendix 7: Installation of Secondary Air Tubes and Baffle ..... 57**

**Appendix 8: Exploded Diagram and Parts List ..... 59**

**OSBURN LIMITED LIFETIME WARRANTY ..... 62**

## PART A - OPERATION AND MAINTENANCE

Please see Part B for installation instructions.

### 1 SAFETY INFORMATION

#### 1.1 SUMMARY OF OPERATION AND MAINTENANCE CAUTIONS AND WARNINGS

- HOT WHILE IN OPERATION, KEEP CHILDREN, CLOTHING AND FURNITURE AWAY. CONTACT MAY CAUSE SKIN BURNS. GLOVES MAY BE NEEDED FOR STOVE OPERATION.
- USING A STOVE WITH CRACKED OR BROKEN COMPONENTS, SUCH AS GLASS OR FIREBRICKS OR BAFFLES MAY PRODUCE AN UNSAFE CONDITION AND MAY DAMAGE THE STOVE.
- OPEN THE AIR CONTROL FULLY BEFORE OPENING FIRING DOOR.
- THIS STOVE HAS BEEN TESTED FOR USE WITH AN OPEN DOOR IN CONJUNCTION WITH A FIRE SCREEN (ACO1315, SOLD SEPARATELY). THE DOOR MAY BE OPEN OR FIRE SCREEN REMOVED ONLY DURING LIGHTING PROCEDURES OR RELOADING. ALWAYS CLOSE THE DOOR OR PUT BACK THE FIRE SCREEN AFTER IGNITION. DO NOT LEAVE THE STOVE UNATTENDED WHEN THE DOOR IS OPENED WITH OR WITHOUT FIRE SCREEN.
- NEVER USE GASOLINE, GASOLINE-TYPE LANTERN FUEL (NAPHTHA), FUEL OIL, MOTOR OIL, KEROSENE, CHARCOAL LIGHTER FLUID, OR SIMILAR LIQUIDS OR AEROSOLS TO START OR 'FRESHEN UP' A FIRE IN THIS STOVE. KEEP ALL SUCH LIQUIDS OR AEROSOLS WELL AWAY FROM THE STOVE WHILE IT IS IN USE.
- DO NOT STORE FUEL WITHIN HEATER MINIMUM INSTALLATION CLEARANCES.
- BURN ONLY SEASONED NATURAL FIREWOOD.
- DO NOT BURN:
  - GARBAGE OF ANY KIND,
  - COAL OR CHARCOAL,
  - TREATED, PAINTED OR COATED WOOD,
  - PLYWOOD OR PARTICLE BOARD,
  - FINE PAPER, COLORED PAPER OR CARDBOARD,
  - SALT WATER DRIFTWOOD, OR
  - RAILROAD TIES.
- DO NOT ELEVATE THE FIRE BY USING A GRATE IN THIS STOVE.
- THIS APPLIANCE SHOULD BE MAINTAINED AND OPERATED AT ALL TIMES IN ACCORDANCE WITH THESE INSTRUCTIONS.

## 2 GENERAL INFORMATION ON OSBURN 2000 (OB02010)

### 2.1 APPLIANCE PERFORMANCE<sup>(1)</sup>

|   |  |                                |
|---|--|--------------------------------|
| Fuel type   | Dry cordwood   |                                |
| Recommended heating area <sup>[1]</sup>                             | 500 to 2,100 ft <sup>2</sup> (47 to 195 m <sup>2</sup> ) |                                |
| Firebox volume  | 2.4 ft <sup>3</sup> (0.068 m <sup>3</sup> )              |                                |
| Maximum burn time <sup>[1]</sup>                                    | 8 h  |                                |
| Maximum heat output <sup>(2)</sup> (dry cordwood)                   | 75,000 BTU/h (22.0 kW)                                   |                                |
| Overall heat output rate (min. to max.) <sup>(2)(3)</sup>           | 12,50 BTU/h to 31,300 BTU/h<br>(3.7 kW to 9.2 kW)        |                                |
| Average overall efficiency <sup>(3)</sup> - EPA Cribs / Douglas Fir | 69.5% (HHV <sup>(4)</sup> )                              | 75.2% (LHV <sup>(5)</sup> )    |
| Average overall efficiency <sup>(3)</sup> - Dry cordwood            | To come% (HHV <sup>(4)</sup> )                           | To come% (LHV <sup>(5)</sup> ) |
| Optimum efficiency <sup>(3)(6)</sup>                                | 77.2%  |                                |
| Average particulate emissions rate <sup>(7)</sup>                   | 3.9 g/h (EPA / CSA B415.1-10)                            |                                |
| Average CO <sup>(8)</sup>   | 137.4 g/h  |                                |

[1] Recommended heating area and maximum burn time may vary subject to location in home, chimney draft, heat loss factors, climate, fuel type and other variables. The recommended heated area for a given appliance is defined by the manufacturer as its capacity to maintain a minimum acceptable temperature in the designated area in case of a power failure.

(1) Values are as measured per test method, except for the recommended heating area, firebox volume, maximum burn time and maximum heat output.

(2) The maximum heat output (dry cordwood) is based on a loading density varying between 15 lb/ft<sup>3</sup> and 20 lb/ft<sup>3</sup>. Other performances are based on a fuel load prescribed by the standard. The specified loading density varies between 7 lb/ft<sup>3</sup> and 12 lb/ft<sup>3</sup>. The moisture content is between 19% and 25%.

(3) As measured per CSA B415.1-10 stack loss method.

(4) Higher Heating Value of the fuel.

(5) Lower Heating Value of the fuel.

(6) Optimum overall efficiency at a specific burn rate (LHV).

(7) This appliance is officially tested and certified by an independent agency.

(8) Carbon monoxide.

## 2.2 GENERAL FEATURES

|  |                                    |
|--|------------------------------------|
| Maximum log length                                 | 20 in (508 mm) east-west*          |
| Flue outlet diameter                               | 6 in (152 mm)                      |
| Recommended connector pipe diameter                | 6 in (152 mm)                      |
| Type of chimney                                    | CAN/ULC S629, UL 103 HT (2100 °F)  |
| Baffle material                                    | C-Cast                             |
| Approved for alcove installation                   | Not approved                       |
| Approved for mobile home installation <sup>‡</sup> | Yes                                |
| Shipping weight (without option)                   | 390 lb (177 kg)                    |
| Appliance weight (model with legs)                 | 368 lb (167 kg)                    |
| Appliance weight (model with pedestal)             | 377 lb (171 kg)                    |
| Type of door                                       | Single, glass with cast iron frame |
| Type of glass                                      | Ceramic glass                      |
| Blower   | Included (up to 130 CFM)           |
| Particulate emission standard                      | EPA / CSA B415.1-10                |
| USA standard (safety)                              | UL 1482, UL 737                    |
| Canadian standard (safety)                         | ULC S627                           |

\*\* East-west: through the door you see the longitudinal sides of the logs; north-south: through the door you see the tips of the logs.

‡ Mobile home (Canada) or manufactured home (USA). The US department of Housing and Urban Development describes “manufactured homes” better known as “mobile homes” as followed; buildings built on fixed wheels and those transported on temporary wheels/axles and set on a permanent foundation. In Canada, a mobile home is a dwelling for which the manufacture and assembly of each component is completed or substantially completed prior to being moved to a site for installation on a foundation and connection to service facilities and which conforms to the CAN/CSA-Z240 MH standard.

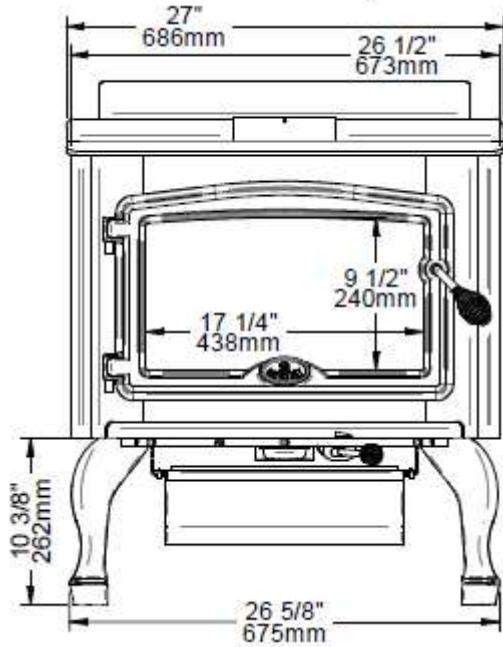
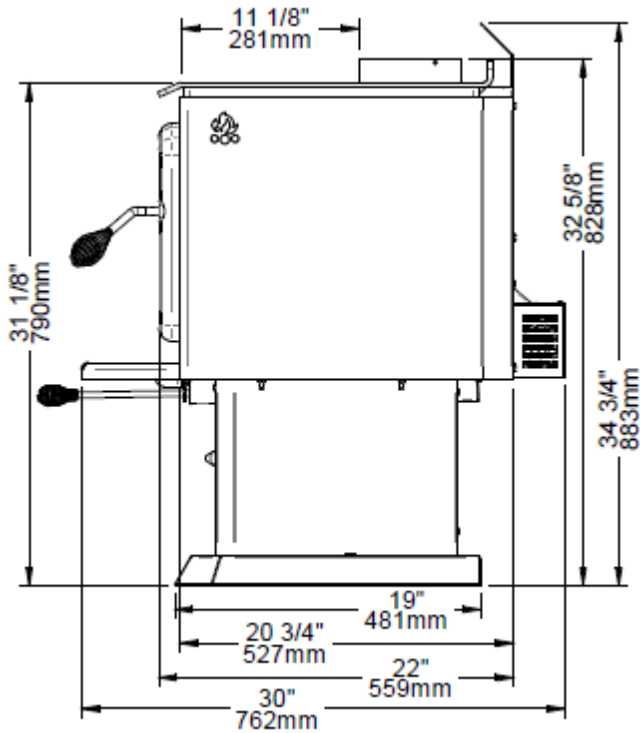
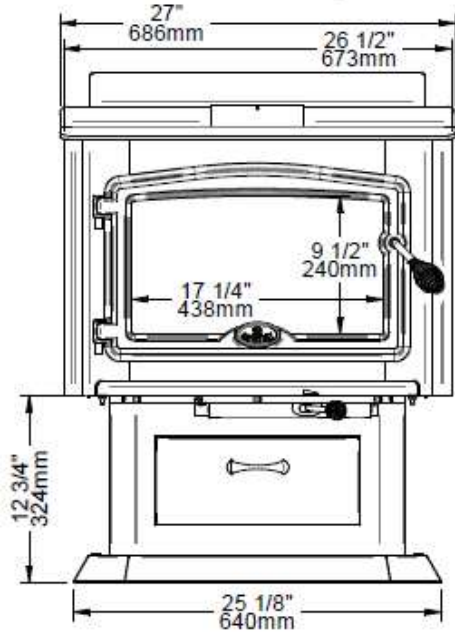
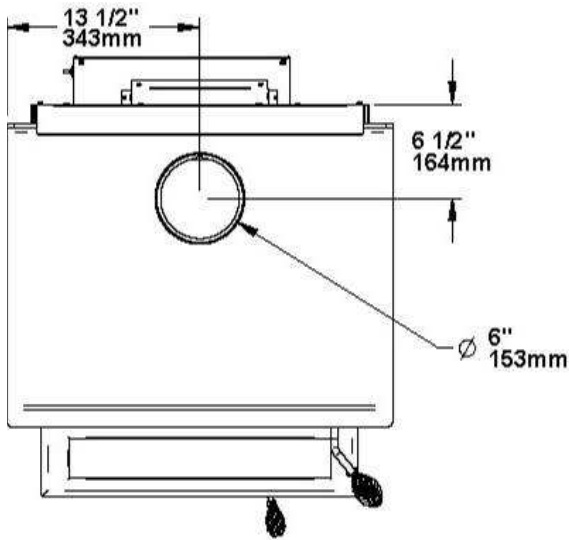



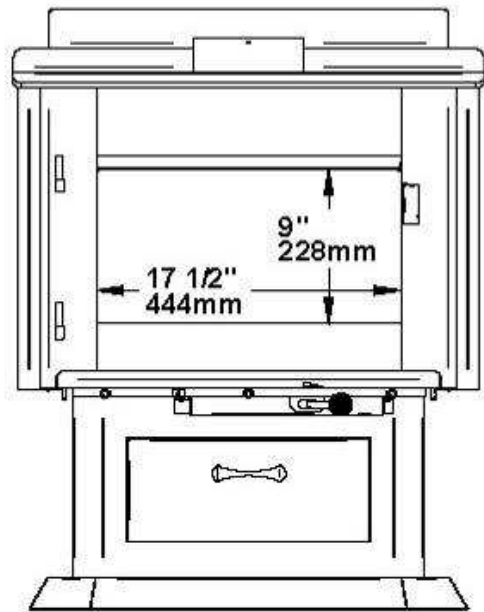
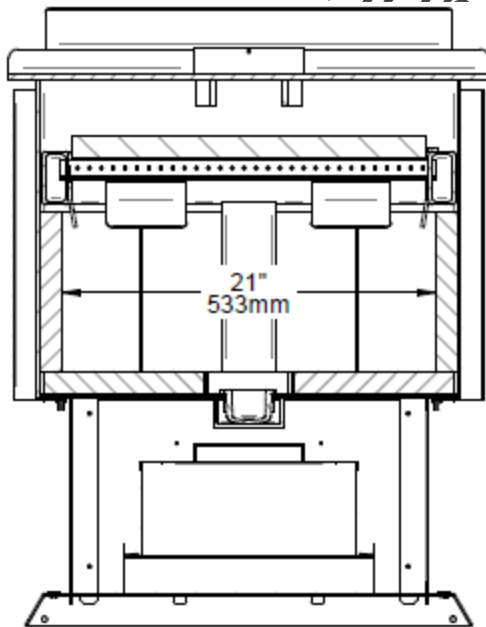
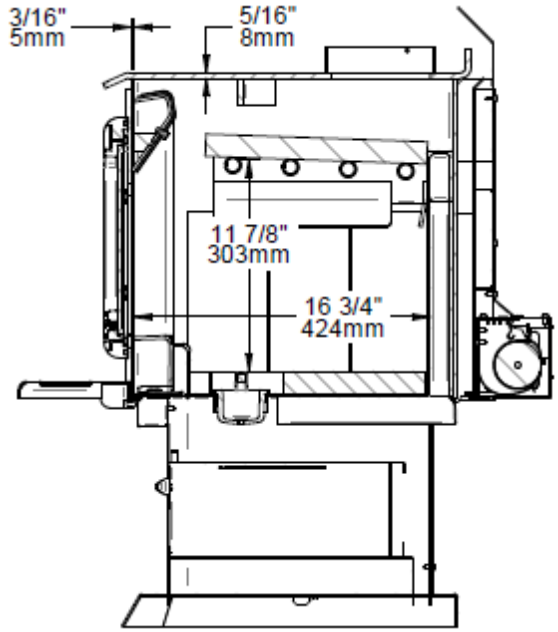
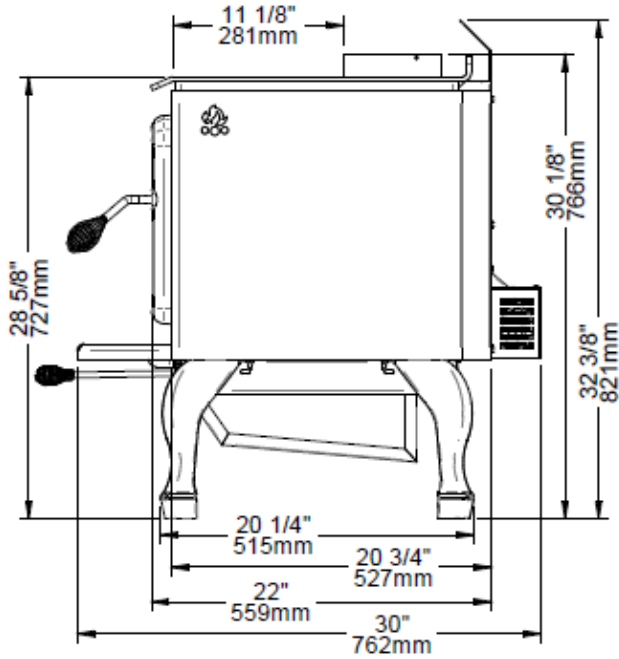

Muleon Ho  
a/Insp

## 2.3 ZONE HEATING AND HOW TO MAKE IT WORK FOR YOU

Your new Osburn 2000 wood stove is a space heater, which means it is intended to heat the area it is installed in, as well as spaces that connect to that area, although to a lower temperature. This is called zone heating and it is an increasingly popular way to heat homes or spaces within homes.

Zone heating can be used to supplement another heating system by heating a particular space within a home, such as a basement family room or an addition that lacks another heat source.

Houses of moderate size and relatively new construction can be heated with a properly sized and located wood stove. Whole house zone heating works best when the stove is located in the part of the house where the family spends most of its time. This is normally the main living area where the kitchen, dining and living rooms are located. By locating the stove in this area, you will get the maximum benefit of the heat it produces and will achieve the highest possible heating efficiency and comfort. The space where you spend most of your time will be warmest, while bedrooms and basement (if there is one) will stay cooler. In this way, you will burn less wood than with other forms of heating.

Although the stove may be able to heat the main living areas of your house to an adequate temperature, we strongly recommend that you also have a conventional oil, gas or electric heating system to provide backup heating.

Your success with zone heating will depend on several factors, including the correct sizing and location of the stove, the size, layout and age of your home and your climate zone. Three-season vacation homes can usually be heated with smaller stoves than houses that are heated all winter.

## 2.4 THE BENEFITS OF LOW EMISSIONS AND HIGH EFFICIENCY

The low smoke emissions produced by the special features inside the Osburn 2000 firebox mean that your household will release up to 90 percent less smoke into the outside environment than if you used an older conventional stove. But there is more to the emission control technologies than protecting the environment.

The smoke released from wood when it is heated contains about half of the energy content of the fuel. By burning the wood completely, your stove releases all the heat energy from the wood instead of wasting it as smoke up the chimney. Also, the features inside the firebox allow you to reduce the air supply to control heat output, while maintaining clean and efficient flaming combustion, which boosts the efficient delivery of heat to your home.

The emission control and advanced combustion features of your stove can only work properly if your fuel is in the correct moisture content range of 15 to 20 percent. See Section A3.0 of this manual for suggestions on preparing fuelwood and judging its moisture.

## 2.5 THE SBI COMMITMENT TO YOU AND THE ENVIRONMENT

The SBI team are committed to protecting the environment, so we do everything we can to use only materials in our products that will have no lasting negative impact on the environment.

### 2.5.1 WHAT IS YOUR NEW STOVE MADE OF?

The body of your stove, which is most of its weight, is carbon steel. Should it ever become necessary many years in the future, almost the entire stove can be recycled into new products, thus eliminating the need to mine new materials.

The paint coat on your stove is very thin. Its VOC content (Volatile Organic Components) is very low. VOCs can be responsible for smog, so all the paint used during the manufacturing process meets the latest air quality requirements with regards to VOC reduction or elimination.

The air tubes are stainless steel, which can also be recycled.

The C-Cast affle is made of an aluminosilicate fibre material that is compressed with a binder to form a rigid board. C-Cast can withstand temperatures above 2,000 °F. It is not considered hazardous waste. Disposal at a landfill is recommended.

Firebrick is mainly composed of silicon dioxide, also known as silica, an earth derived product. It is most commonly found in nature in the form of sand and clay. Disposal at a landfill is recommended.

The door and glass gaskets are fibreglass which is spun from melted sand. Black gaskets have been dipped into a solvent-free solution. Disposal at a landfill is recommended.

The door glass is a 5 mm thick ceramic material that contains no toxic chemicals. It is basically made of raw earth materials such as sand and quartz that are combined in such a way to form a glass at high temperatures. Ceramic glass will not re-melt in the same way as normal glass, so it should not be recycled with your regular household products. Disposal at a landfill is recommended.

## 3 FUEL

### 3.1 MATERIALS THAT SHOULD NOT BE BURNED

- GARBAGE OF ANY KIND,
- COAL OR CHARCOAL,
- TREATED, PAINTED OR COATED WOOD,
- PLYWOOD OR PARTICLE BOARD,
- FINE PAPER, COLORED PAPER OR CARDBOARD,
- SALT WATER DRIFTWOOD,
- MANUFACTURED LOGS CONTAINING WAX OR CHEMICAL ADDITIVES,
- RAILROAD TIES,
- LIQUIDS SUCH AS KEROSENE OR DIESEL FUEL TO START A FIRE.

### 3.2 HOW TO PREPARE OR BUY GOOD FIREWOOD

#### 3.2.1 WHAT IS GOOD FIREWOOD?

Good firewood has been cut to the correct length for the stove, split to a range of sizes and stacked in the open until its moisture content is reduced to 15 to 20 per cent.

#### 3.2.2 TREE SPECIES

The tree species the firewood is produced from is less important than its moisture content. The main difference in firewood from various tree species is the density of the wood. Hardwoods are denser than softwoods. People who live in the coldest regions of North America usually have only spruce, birch and poplar, other low-density species to burn and yet they can heat their homes successfully.

Homeowners with access to both hardwood and softwood fuel sometimes use both types for different purposes. For example, softer woods make good fuel for relatively mild weather in spring and fall because they light quickly and produce less heat. Softwoods are not as dense as hardwoods so a given volume of wood contains less energy. Using softwoods avoids overheating the house, which can be a common problem with wood heating in moderate weather. Harder woods are best for colder winter weather when more heat and longer burn cycles are desirable.

Note that hardwood trees like oak, maple, ash and beech are slower growing and longer lived than softer woods like poplar and birch. That makes hardwood trees more valuable. The advice that only hardwoods are good to burn is outdated. Old, leaky cast iron stoves wouldn't hold a fire overnight unless they were fed large pieces of hardwood. That is no longer true. You can successfully heat your home by using the less desirable tree species and give the forest a break at the same time.

### 3.2.3 LOG LENGTH

Logs should be cut about 1" (25 mm) shorter than the firebox so they fit in easily. Pieces that are even slightly too long make loading the stove very difficult. The most common standard length of firewood is 16" (400 mm).

The pieces should be a consistent length, with a maximum of 1" (25 mm) variation from piece to piece.

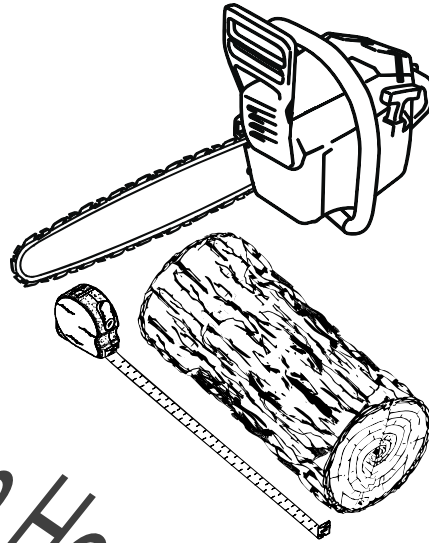

### 3.2.4 PIECE SIZE

Firewood dries more quickly when it is split. Large unsplit rounds can take years to dry enough to burn. Even when dried, unsplit logs are difficult to ignite because they don't have the sharp edges where the flames first catch. Logs as small as 3" (75 mm) should be split to encourage drying.

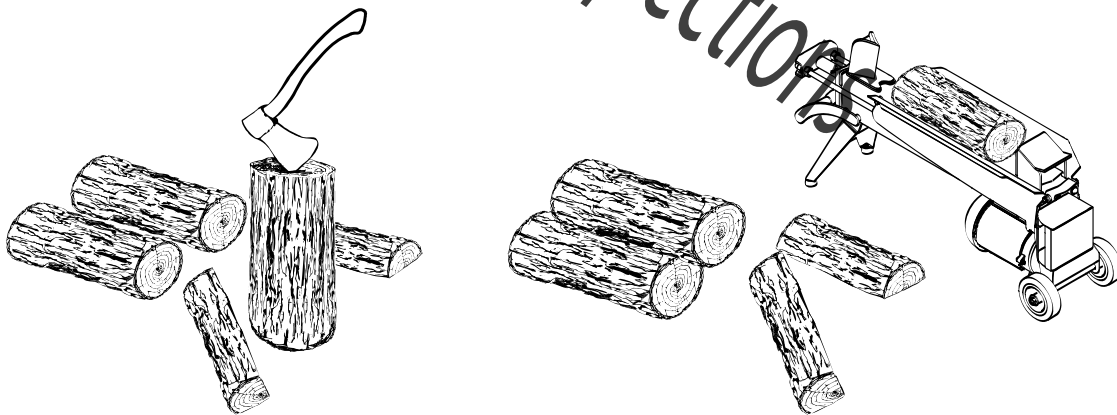

Wood should be split to a range of sizes, from about 3" to 6" (75 mm to 150 mm) in cross section. Having a range of sizes makes starting and rekindling fires much easier. Often, the firewood purchased from commercial suppliers is not split finely enough for convenient stoking. It is sometimes advisable to resplit the wood before stacking to dry.

### 3.2.5 HOW TO DRY FIREWOOD

Firewood that is not dry enough to burn is the cause of most complaints about wood stoves. The complaints usually involve a lack of heat and dirty door glass.

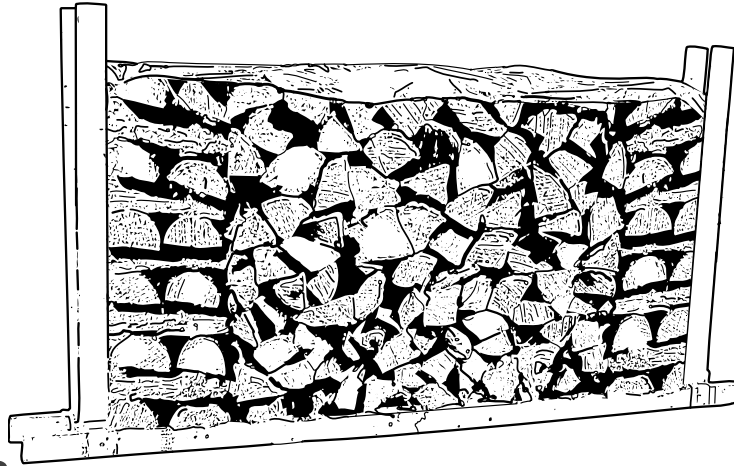

Here are some things to consider in estimating drying time:

- firewood takes a long time to dry
- firewood bought from a dealer is rarely dry enough to burn, so it is advisable to buy the wood in spring and dry it yourself
- drying happens faster in dry weather than in damp, maritime climates
- drying happens faster in warm summer weather than in winter weather
- small pieces dry more quickly than large pieces
- split pieces dry more quickly than unsplit rounds
- softwoods take less time to dry than hardwoods
- softwoods like pine, spruce, and poplar/aspens can be dry enough to burn after being stacked in the open for only the summer months
- hardwoods like oak, maple and ash can take one, or even two years to dry fully, especially if the pieces are big
- firewood dries more quickly when stacked in the open where it is exposed to sun and wind; it takes much longer to dry when stacked in a wood shed
- firewood that is ready to burn has a moisture content between 15 and 20% by weight and will allow your stove to produce its highest possible efficiency

### 3.2.6 JUDGING FIREWOOD MOISTURE CONTENT

You can find out if some firewood is dry enough to burn by using these guidelines:

- cracks form at the ends of logs as they dry
- as it dries in the sun, the wood turns from white or cream coloured to grey or yellow,
- bang two pieces of wood together; seasoned wood sounds hollow and wet wood sounds dull,
- dry wood is much lighter in weight than wet wood,
- split a piece, and if the fresh face feels warm and dry it is dry enough to burn; if it feels damp, it is too wet,
- burn a piece; wet wood hisses and sizzles in the fire and dry wood does not.

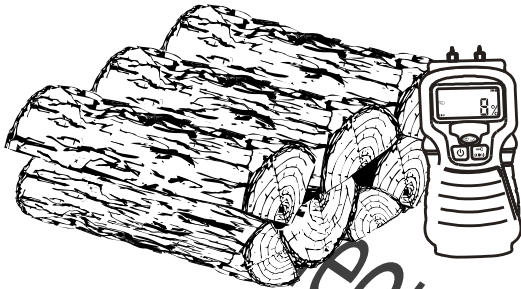

You could buy a wood moisture meter to test your firewood.

### 3.3 MANUFACTURED LOGS

Do not burn manufactured logs made of wax impregnated sawdust or logs with any chemical additives. Manufactured logs made of 100% compressed sawdust can be burned, but use caution in the number of these logs burned at one time. Start with one manufactured log and see how the stove reacts. You can increase the number of logs burned at a time to making sure the temperature never rises higher than 475 °F (246 °C) on a magnetic thermometer for installation on single wall stove pipes or 900 °F (482 °C) on a probe thermometer for installation on double wall stove pipe. The thermometer should be placed about 18" (457 mm) above the stove. Higher temperatures can lead to overheat and damage your stove.

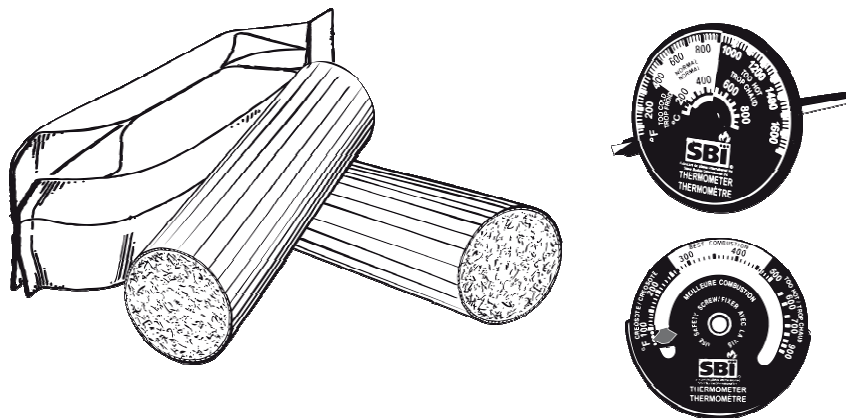

## 4 OPERATING YOUR STOVE

### 4.1 THE USE OF A FIRE SCREEN.

This stove has been tested for use with an open door in conjunction with a fire screen (AC01315, sold separately). Make sure the fire screen is properly secured on the stove to avoid any risk of fire. When the fire screen is used, it is important not to leave the stove unattended to respond promptly in the event of smoke spillage into the room. Potential causes of smoke spillage are described in section height of this manual. See **Appendix 6: Installing the Fire Screen (AC01315)** for installation instructions.

### 4.2 YOUR FIRST FIRES

Two things will happen as you burn your first few fires; the paint cures and the internal components of the stove are conditioned.

As the paint cures, some of the chemicals vaporize. The vapors are not poisonous, but they do smell bad. Fresh paint fumes can also cause false alarms in smoke detectors. So, when you first light your stove, be prepared by opening doors and/or windows to ventilate the house. As you burn hotter and hotter fires, more of the painted surfaces reach the curing temperature of the paint. The smell of curing paint does not disappear until you have burned one or two very hot fires.

Burn one or two small fires to begin the curing and conditioning process. Then build bigger and hotter fires until there is no longer any paint smell from the stove. Once the paint smell disappears, your stove is ready for serious heating.

### 4.3 LIGHTING FIRES

Each person who heats with wood develops their own favorite way to light fires. Whatever method you choose, your goal should be to get a hot fire burning quickly. A fire that starts fast produces less smoke and deposits less creosote in the chimney. Here are three popular and effective ways to start wood fires.



### 4.3.1 CONVENTIONAL FIRE STARTING

The conventional way to build a wood fire is to bunch up 5 to 10 sheets of plain newspaper and place them in the firebox. Next, place 10 or so pieces of fine kindling on the newspaper. This kindling should be very thin; less than 1" (25 mm). Next, place some larger kindling pieces on the fine kindling. Open the air control fully and light the newspaper. If you have a tall, straight venting system you should be able to close the door immediately and the fire will ignite. If your venting system has elbows or an outside chimney, you may need to leave the door closed but unlatched for a few minutes as the newspaper ignites and heat in the chimney produces some draft. Once the fire has ignited, close the door and leave the air control fully open.

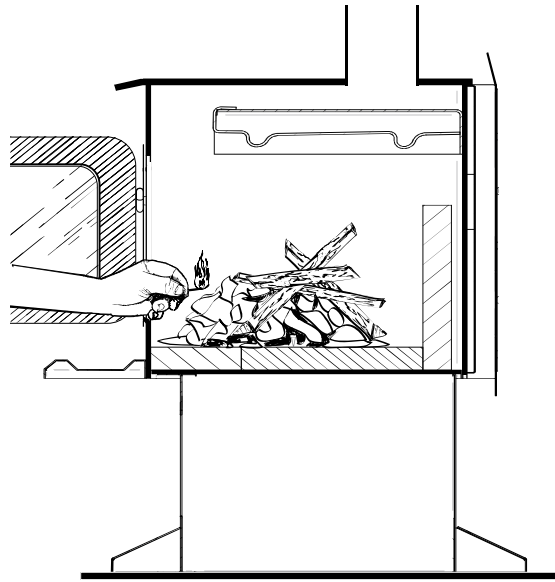

*A conventional kindling fire with paper under finely split wood.*

**DO NOT LEAVE THE STOVE UNATTENDED WHEN THE DOOR IS SLIGHTLY OPENED DURING IGNITION. ALWAYS CLOSE THE DOOR AFTER IGNITION.**

After the kindling fire has mostly burned, you can add standard firewood pieces until you have a fire of the right size for the conditions.

### 4.3.2 THE TOP DOWN FIRE

The top down fire starting method solves two problems with the conventional method: first, it does not collapse and smother itself as it burns; and second, it is not necessary to build up the fire gradually because the firebox is loaded before the fire is lit. A top down fire can provide up to two hours of heating or more. The top down method only works properly if the wood is well-seasoned.

Start by placing three or four full-sized split pieces of dry firewood in the firebox. Next, place 4 or 5 more finely split pieces of firewood (2" to 3" [50 mm to 75 mm] in dia.) on the base logs at right angles (log cabin style). Now place about 10 pieces of finely split kindling on the second layer at right angles.

The fire is topped with about 5 sheets of newspaper. You can just bunch them up and stuff them in between the kindling and the underside of the baffle. Or you can make newspaper knots by rolling up single sheets corner to corner and tying a knot in them. The advantage of knots is that they don't roll off the fire as they burn. Light the newspaper and watch as the fire burns from top to bottom.

### 4.3.3 TWO PARALLEL LOGS

Place two spit logs in the firebox. Place a few sheets of twisted newspaper between the logs. Now place some fine kindling across the two logs and some larger kindling across those, log cabin style. Light the newspaper.

### 4.3.4 USING FIRE STARTERS

Many people like to use commercial fire starters instead of newspaper. Some of these starters are made of sawdust and wax and others are specialized flammable solid chemicals. Follow the package directions for use.

Gel starter may be used but only if there are no hot embers present. Use only in a cold firebox to start a fire.

**DO NOT USE FLAMMABLE LIQUIDS SUCH AS GASOLINE, NAPHTHA, FUEL OIL, MOTOR OIL, OR AEROSOLS TO START OR REKINDLE THE FIRE.**

## 4.4 MAINTAINING WOOD FIRES

### 4.4.1 GENERAL ADVICE

Wood heating with a space heater is very different than other forms of heating. There will be variations in the temperature in different parts of the house and there will be variations in temperature throughout the day and night. This is normal, and for experienced wood burners these are advantages of zone heating with wood.

Do not expect steady heat output from your stove. It is normal for its surface temperature to rise after a new load of wood is ignited and for its temperature to gradually decline as the fire progresses. This rising and falling of temperature can be matched to your household routines. For example, the area temperature can be cooler when you are active, such as when doing housework or cooking, and it can be warmer when you are inactive such as when reading or watching television.

Wood burns best in cycles. A cycle starts when a new load of wood is ignited by hot coals and ends when that load has been consumed down to a bed of charcoal about the same size as it was when the wood was loaded. Do not attempt to produce a steady heat output by placing a single log on the fire at regular intervals. Always place at least three, and preferably more, pieces on the fire at a time so that the heat radiated from one piece helps to ignite the pieces next to it. Each load of wood should provide several hours of heating. The size of each load can be matched to the amount of heat needed.

When you burn in cycles, you rarely need to open the stove's loading door while the wood is flaming. This is an advantage because there is more chance that smoke will leak from the stove when the door is opened as a full fire is burning. This is especially true if the chimney connector has 90 degree elbows and if the chimney runs up the outside wall of the house.

**IF YOU MUST OPEN THE DOOR WHILE THE FUEL IS FLAMING, OPEN THE AIR CONTROL FULLY FOR A FEW MINUTES, THEN UNLATCH AND OPEN THE DOOR SLOWLY.**

#### 4.4.2 ASH REMOVAL

Ash should be removed from the firebox every two or three days of full time heating. Do not let the ash build up in the firebox because it will interfere with proper fire management.

The best time to remove ash is after an overnight fire when the stove is relatively cool, but there is still some chimney draft to draw the ash dust into the stove and prevent it from coming into the room.

After ashes have been removed from the stove and placed in a tightly covered metal container, they should be taken outside immediately. The closed container of ashes should be placed on a non-combustible floor or on the ground well away from all combustible materials pending final disposal. Ashes normally contain some live charcoal that can stay hot for several days. If the ashes are disposed of by burial in soil or otherwise locally dispersed, they should be retained in the closed container until all cinders have thoroughly cooled. Other waste shall not be placed in this container.

**NEVER STORE ASHES INDOORS OR IN A NON-METALIC CONTAINER OR ON A WOODEN DECK.**

#### 4.4.3 RAKING CHARCOAL

Rekindle the fire when you notice that the room temperature has fallen. You will find most of the remaining charcoal at the back of the firebox, furthest from the door. Rake these coals towards the door before loading. There are two reasons for this raking of the coals. First, it concentrates them near where most of the combustion air enters the firebox and where they can ignite the new load quickly, and second, the charcoal will not be smothered by the new load of wood. If you were to simply spread the charcoal out, the new load will smoulder for a long time before igniting.

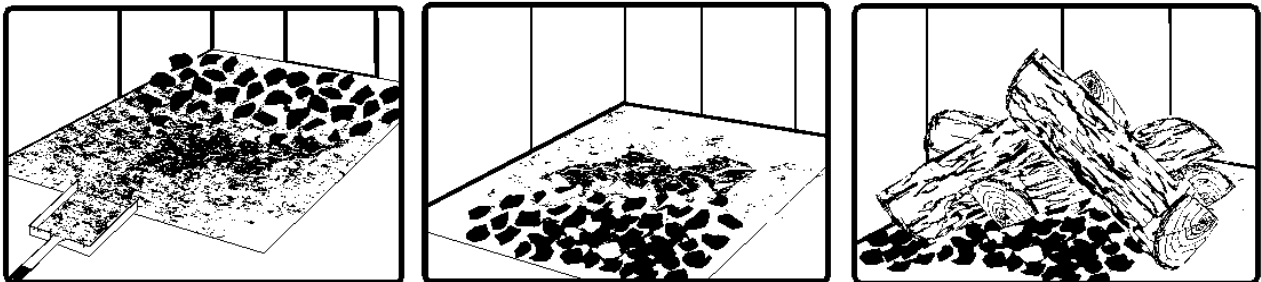

*Remove ash first, and then rake charcoal towards the front of the firebox before loading so that it will ignite the new load.*

#### 4.4.4 FIRING EACH NEW LOAD HOT

Place the new load of wood on and behind the charcoal, and not too close to the glass. Close the door and open the air control fully. Leave the air control fully open until the firebox is full of flames, the wood has charred to black and its edges are glowing red. Firing each load of wood hot accomplishes a few things:

- drives the surface moisture from the wood,
- creates a layer of char on the wood, which slows down its release of smoke,
- heats the firebox components so they reflect heat back to the fire, and
- heats the chimney so it can produce strong, steady draft for the rest of the cycle.

Although it is important to fire each new load hot to prepare for a clean burn, do not allow the fire to burn at full intensity for more than a few minutes.

#### **DO NOT LEAVE THE STOVE UNATTENDED WHILE A NEW LOAD IS BEING FIRED HOT.**

When you burn a new load of wood hot to heat up the wood, the stove and the chimney, the result will be a surge of heat from the stove. This heat surge is welcome when the room temperature is a little lower than desirable, but not welcome if the space is already warm. Therefore, allow each load of wood to burn down so that the space begins to cool off a little before loading. Letting the space cool before loading is one of the secrets to clean burning and effective zone heating.

#### 4.4.5 TURNING DOWN THE AIR SUPPLY

Once the firewood, firebox and chimney are hot, you can begin to reduce the air supply for a steady burn.

As you reduce the air supply to the fire, two important things happen. First, the firing rate slows down to spread the heat energy in the fuel over a longer period of time. Second, the flow rate of exhaust through the stove and flue pipe slows down, which gives more time for the transfer of heat from the exhaust. You will notice that as you reduce the air setting, the flames slow down. This is your indication that the stove is burning at its peak efficiency.

If the flames get small and almost disappear when you turn down the air, you have turned down the air too early, or your firewood is wetter than it should be. With good fuel and correct air control use, the flames should slow down, but should stay large and steady, even as the air supply is reduced.

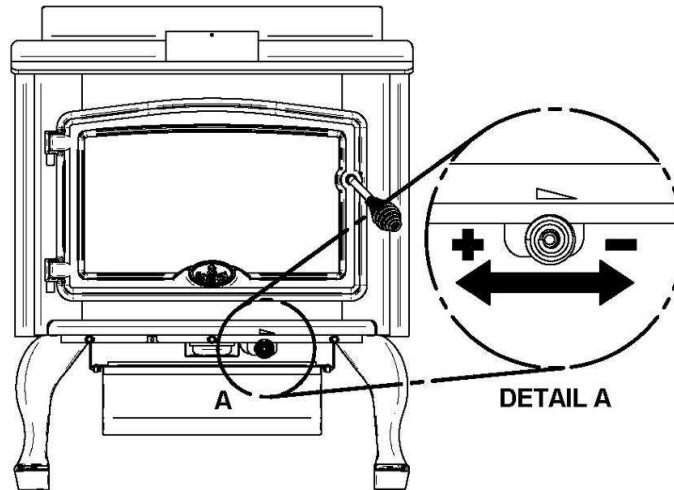

#### 4.4.6 BUILDING DIFFERENT FIRES FOR DIFFERENT NEEDS

Using the air control is not the only way to match the stove's heat output to the heat demand. Your house will need far less heat in October than in January to be kept at a comfortable temperature. If you fill the firebox full in fall weather, you will either overheat the space or turn the stove down so much that the fire will be smoky and inefficient. Here are some suggestions for building fires to match different heat demand.

##### 4.4.6.1 Small Fires to Take the Chill Off the House

To build a small fire that will produce a low heat output, use small pieces of firewood and load them crisscross in the firebox. The pieces should be only 3" to 4" in diameter. After raking the coals, you can lay two pieces parallel to each other corner to corner in the firebox and lay two more across them in the other direction. Open the air control fully and only reduce the air after the wood is fully flaming. This kind of fire is good for mild weather when you are around to tend the stove and should provide enough heat for four hours or more. Small fires like this are a good time to use softer wood species so there will be less chance of overheating the house.

##### 4.4.6.2 Long Lasting Low Output Fires

Sometimes you will want to build a fire to last up to eight hours, but don't need intense heat. In this case use soft wood species and place the logs compactly in the firebox so the pieces are packed tightly together. You will need to fire the load hot for long enough to fully char the log surfaces before you can turn the air down. Make sure the fire is flaming brightly before leaving the fire to burn.

##### 4.4.6.3 High Output Fires for Cold Weather

When the heat demand is high during cold weather, you'll need a fire that burns steadily and brightly. This is the time to use your biggest pieces of hardwood fuel if you have it. Put the biggest pieces at the back of the firebox and place the rest of the pieces compactly. A densely built fire like this will produce the longest burn your stove is capable of.

You will need to be cautious when building fires like this because if the air is turned down too much, the fire could smoulder. Make sure the wood is flaming brightly before leaving the fire to burn.

#### 4.4.6.4 Maximum Burn Cycle Times

The burn cycle time is the period between loading wood on a coal bed and the consumption of that wood back to a coal bed of the same size. The flaming phase of the fire lasts for roughly the first half of the burn cycle and the second half is the coal bed phase during which there is little or no flame. The length of burn you can expect from your stove, including both the flaming and coal bed phases, will be affected by a number of things, such as:

- firebox size,
- the amount of wood loaded,
- the species of wood you burn,
- the wood moisture content,
- the size of the space to be heated,
- the climate zone you live in, and
- the time of year.

The table below provides a very general indication of the maximum burn cycle times you are likely to experience, based on firebox volume.

| FIREBOX VOLUME       | MAXIMUM BURN TIME |
|----------------------|-------------------|
| <1.5 cubic feet      | 3 to 5 hours      |
| 1.5 c.f. to 2.0 c.f. | 5 to 6 hours      |
| 2.0 c.f. to 2.5 c.f. | 6 to 8 hours      |
| 2.5 c.f. to 3.0 c.f. | 8 to 9 hours      |
| >3.0 c.f.            | 9 to 10 hours     |

Long burn times are not necessarily an indication of efficient stove operation. When you are home during the day and able to tend the fire, it is preferable to build a smaller fire that might provide three or four hours of heating than to fully load the firebox for a much longer burn. Shorter burn cycles make it easier to match the heat output of the stove to the heat demand of the space.

#### 4.4.6.5 North-South Fires Versus East-West Fires

In fireboxes that are roughly square, wood can be loaded so that looking through the glass door you see the ends of the logs (north-south) or the sides of the logs (east-west).

East-west loads that are built compactly break down slowly when heated, but the amount of wood you can load is limited because if you put in too many pieces, one may fall against the glass. East-west loads are excellent for long, low output fires for relatively mild weather.

North-south loads break down more quickly, but much more wood can be loaded at a time. This makes north-south loading good for high output, long lasting fires for cold weather.

## 5 MAINTAINING YOUR WOOD HEATING SYSTEM

### 5.1 STOVE MAINTENANCE

Your new stove will give many years of reliable service if you use and maintain it correctly. Some of the internal components of the firebox, such as firebricks, baffles and air tubes, will wear over time under intense heat. You should always replace defective parts with original parts (see **Appendix 9: Exploded Diagram and Parts List**). For firing each load hot to begin a cycle as described above will not cause premature deterioration of the stove. However, letting the stove run with the air control fully open for entire cycles can cause damage over time. The hotter you run the stove throughout burn cycles, the more quickly its components will deteriorate. For that reason, **never leave the stove unattended while a new load is being fired hot.**

#### 5.1.1 CLEANING DOOR GLASS

Under normal conditions, your door glass should stay relatively clear. If your firewood is dry enough and you follow the operating instructions in this manual, a whitish, dusty deposit will form on the inside of the glass after a week or so of use. This is normal and can be easily removed when the stove is cool by wiping with a damp cloth or paper towel and then drying. **Never try to clean the glass when the stove is hot.**

In spring and fall when the stove is run at lower temperatures, you may see some light brown stains forming, especially at the lower corners of the glass. This indicates that the fire has been smoky and some of the smoke has condensed on the glass. When the weather is mild, you may find that letting the fire go out is better than trying to maintain a continuous fire. Use the technique described above for building a fire to take the chill off the house.

If you do get brown stains on the glass you can remove them with special cleaners for wood stove glass doors. **Do not use abrasives to clean your stove's door glass.**

The deposits that form on the glass are the best indication of the quality of your fuel and how well you are doing in operating the stove. Your goal should be clear glass with no brown stains. If you continue to see brown stains on the glass, something about your fuel and operating procedure needs to be changed. Stains on the glass indicate incomplete combustion of the wood, which also means more smoke emissions and faster formation of creosote in the chimney.

If you see brown streaks coming from the edge of the glass, it is time to replace the gasket around the glass. Visit your stove retailer to get the self-adhesive glass gasket and follow the instructions below for installation.

### 5.1.2 DOOR ADJUSTMENT

In order for your stove to burn at its best efficiency, the door must provide a perfect seal with the firebox. Therefore, the gasket should be inspected periodically making sure to obtain an air tight fit. Airtightness can be improved with a simple latch mechanism adjustment. To adjust:

1. Remove the lock pin (spring pin) by pulling and turning it using pliers ("wise grip").
2. Turn the handle counter clock wise one turn to increase pressure.
3. Re-install the lock pin (spring pin) with a small hammer.

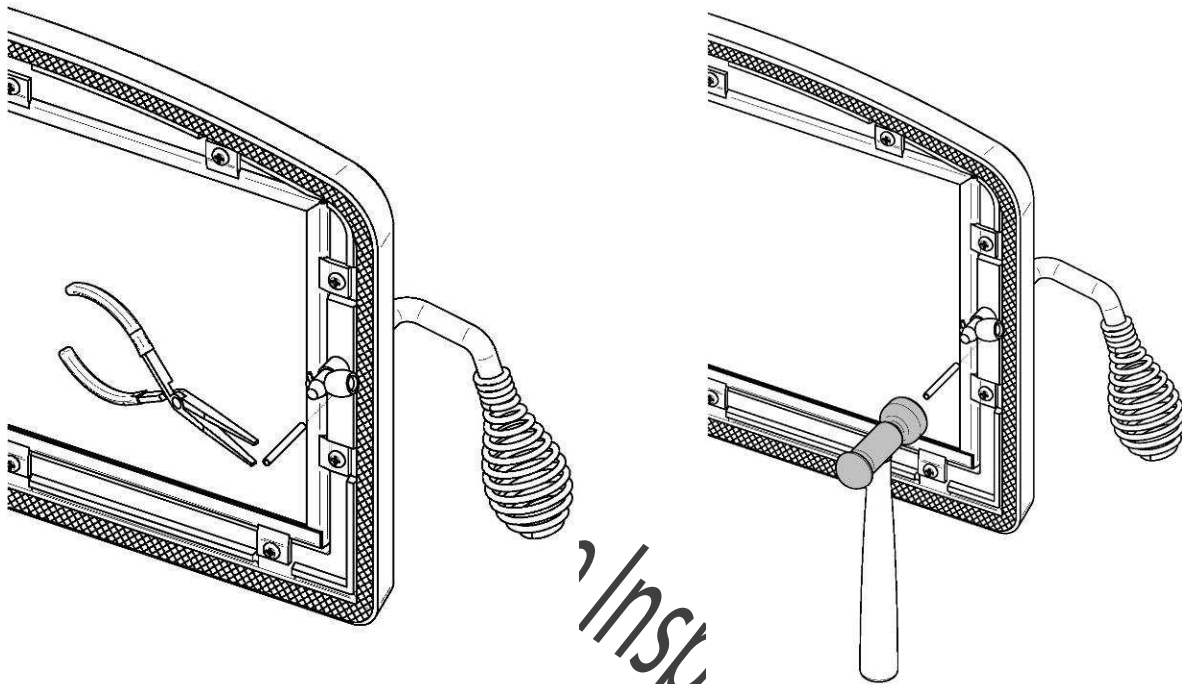

### 5.1.3 REPLACING THE DOOR GASKET

It is important to maintain the gasket in good condition. After a year or more of use, the door gasket will compress and become hard, which may allow air to leak past it. You can test the condition of the door gasket by closing and latching the door on a strip of paper. Test all around the door. If the paper slips out easily anywhere, it is time to replace the gasket.

Use the correct replacement gasket that you can purchase from your retailer. The diameter and density of the gasket is important to getting a good seal.

Place the door face-down on something soft like a cushion of rags or piece of carpet. Remove the old gasket from the door by pulling and prying it out with an old screw driver. Then use the screwdriver to scrape the old gasket adhesive from the door. Now run a 1/4" (6 mm) bead of high temperature silicone in the door gasket groove. Starting from the middle of the hinge side, press the gasket into the groove. Do not stretch the gasket as you place it. Leave the gasket about 1/2" long when you cut it and press the end into the groove. Tuck any loose fibres under the gasket and into the silicone. Close the door and do not use the stove for 24 hours.



#### 5.1.4 REPLACING THE GLASS GASKET AND/OR THE GLASS

It is a good idea to replace the glass gasket when the door gasket is replaced. The gasket is flat, adhesive-backed, woven fibreglass. Remove the glass retaining screws and clips. Lift out the glass and pull off the old gasket. This is a good time to clean the glass thoroughly.

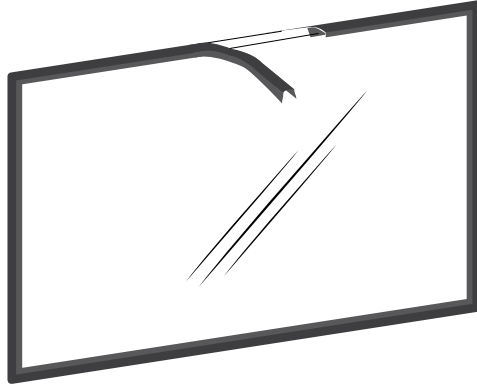

The gasket must be centred on the edge of the glass. To do this easily, peel back a section of the paper covering the adhesive and place the gasket on a table with the adhesive side up. Stick the end of the gasket to the middle of one edge, then press the edge of the glass down onto the gasket, taking care that it is perfectly centred on the gasket. Peel off more of the backing and rotate the glass and press the next section onto the gasket. Do not stretch the gasket as you place it. Continue until you get to the start and trim the gasket to length. Now pinch the gasket to the glass in a U shape, all around the glass. Reinstall the glass, being careful to centre the glass carefully in the door. Do not over-tighten the screws. Note that the two main causes of broken door glass are uneven placement in the door and over-tightening of retaining screws.

Do not abuse the glass door by striking or slamming shut. Do not use the stove if the glass is broken.

To replace the glass (D), remove the eight screws (A), the eight glass retainers (B), and the metal frames (C). Remove the damaged glass and install the new one in place. Make sure you have a gasket around the replacement glass (see procedure above). Put back the metal frames and the glass retainers and secure to the door frame (E) with the screws removed earlier.

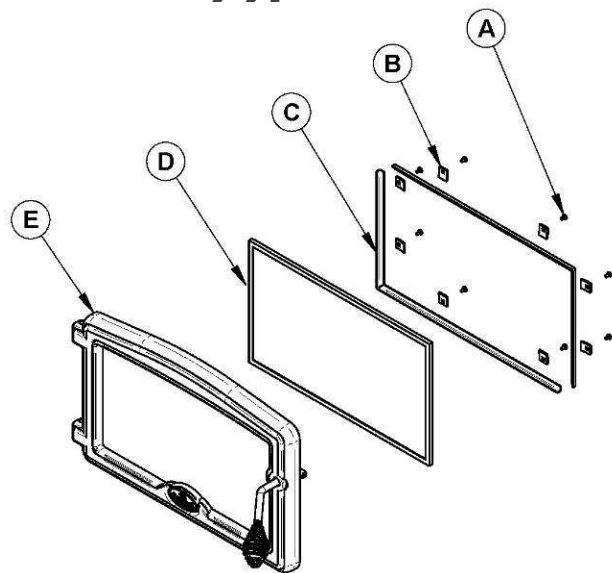

### 5.1.5 CLEANING AND PAINTING THE STOVE

**Do not attempt to clean or paint the stove when the unit is hot.** Painted surfaces can be wiped down with a damp cloth. Plated surfaces may be scratched by abrasive cleaners. To maintain the finish at its original brilliance, use only a damp soft cloth to clean plated surfaces.

If the paint becomes scratched or damaged, you can give your wood stove a brand new look by repainting it with heat-resistant paint. Before painting, roughen the surface with fine sand paper, wipe it down to remove dust, and apply two thin coats of paint. For best results, use the same paint that was originally used on the stove, which is available in spray cans. See your dealer for details.

## 5.2 CHIMNEY AND CHIMNEY CONNECTOR MAINTENANCE

### 5.2.1 WHY CHIMNEY CLEANING IS NECESSARY

Wood smoke can condense inside the chimney connector and chimney, forming a combustible deposit called creosote. If creosote is allowed to build up in the venting system it can ignite when a hot fire is burned in the stove and a very hot fire can progress to the top of the chimney. Severe chimney fires can damage even the best chimneys. Smouldering, smoky fires can quickly cause a thick layer of creosote to form. When you avoid smouldering so the exhaust from the chimney is mostly clear, creosote builds up more slowly. Your new stove has the right characteristics to help you to burn clean fires with little or no smoke, resulting in less creosote in the chimney.

### 5.2.2 HOW OFTEN SHOULD YOU CLEAN THE CHIMNEY?

It is not possible to predict how much or how quickly creosote will form in your chimney. It is important, therefore, to check the build-up in your chimney monthly when getting used to the new stove until you determine the rate of creosote formation. Even if creosote forms slowly in your system, the chimney should be cleaned and inspected at least once each year.

Contact your local municipal or provincial fire authority for information on how to handle a chimney fire. Have a clearly understood plan to handle a chimney fire.

### 5.2.3 CLEANING THE CHIMNEY

Chimney cleaning can be a difficult and dangerous job. If you don't have experience cleaning chimneys, you might want to hire a professional chimney sweep to clean and inspect the system for the first time. After having seen the cleaning process, you can decide if it is a job you would like to take on.

The most common equipment used are fiberglass rods with threaded fittings and stiff plastic brushes. The brush is forced up and down inside the chimney flue to scrub off the creosote.

The chimney connector assembly should always be cleaned at the same time the chimney is cleaned.



**CAUTION:** Operation of your stove without the baffle may cause unsafe and hazardous temperature conditions and will void the warranty. **NOTE:** Before installing the firebrick, check to ensure that none are broken or damaged in any way. If so, have the damaged ones replaced. Check the firebrick for damage at least annually and replace any broken or damaged ones with new ones. Inspection and cleaning of the chimney is facilitated by the removable baffle.

Napoleon Home Inspections

## PART B - INSTALLATION

### 6 SAFETY INFORMATION

#### 6.1 SUMMARY OF INSTALLATION CAUTIONS AND WARNINGS

- THE INFORMATION GIVEN ON THE CERTIFICATION LABEL AFFIXED TO THE APPLIANCE ALWAYS OVERRIDES THE INFORMATION PUBLISHED, IN ANY OTHER MEDIA (OWNER'S MANUAL, CATALOGUES, FLYERS, MAGAZINES AND/OR WEB SITES).
- MIXING OF APPLIANCE COMPONENTS FROM DIFFERENT SOURCES OR MODIFYING COMPONENTS MAY RESULT IN HAZARDOUS CONDITIONS. WHERE ANY SUCH CHANGES ARE PLANNED, STOVE BUILDER INTERNATIONAL INC. SHOULD BE CONTACTED IN ADVANCE.
- ANY MODIFICATION OF THE APPLIANCE THAT HAS NOT BEEN APPROVED IN WRITING BY THE TESTING AUTHORITY VIOLATES CSA B365 (CANADA), AND ANSI NFPA 211 (USA).
- CONNECT THIS STOVE ONLY TO A LISTED FACTORY-BUILT CHIMNEY FOR USE WITH SOLID FUEL OR TO A LINED MASONRY CHIMNEY CONFORMING TO NATIONAL AND LOCAL BUILDING CODES.
- IF REQUIRED, A SUPPLY OF COMBUSTION AIR SHALL BE PROVIDED TO THE ROOM OR SPACE.
- DO NOT CONNECT TO OR USE IN CONJUNCTION WITH ANY AIR DISTRIBUTION DUCTWORK UNLESS SPECIFICALLY APPROVED FOR SUCH INSTALLATION.
- DO NOT CONNECT THIS UNIT TO A CHIMNEY FLUE SERVING ANOTHER APPLIANCE.
- MAY BE INSTALLED IN A MOBILE HOME
- THIS MOBILE HOME APPROVED STOVE REQUIRES INSTALLATION OF A FRESH AIR KIT, SOLD SEPARATELY.

**WARNING: DO NOT INSTALL IN SLEEPING ROOM.**

**WARNING: THE STOVE MUST BE ATTACHED TO THE STRUCTURE OF THE MOBILE HOME.**

**CAUTION: THE STRUCTURAL INTEGRITY OF THE MOBILE HOME FLOOR, WALL, AND CEILING/ROOF MUST BE MAINTAINED.**

#### 6.2 REGULATIONS COVERING STOVE INSTALLATION

When installed and operated as described in these instructions, the Osburn 2000 wood stove is suitable for use as a freestanding heater in residential installations. The Osburn 2000 wood stove is not intended for installation in a sleeping room of a mobile home.

In Canada, the CSA B365 Installation Code for Solid Fuel Burning Appliances and Equipment and the CSA C22.1 Canadian National Electrical Code are to be followed in the absence of local code requirements. In the USA, the ANSI NFPA 211 Standard for Chimneys, Fireplaces, Vents and Solid Fuel-Burning Appliances and the ANSI NFPA 70 National Electrical Code are to be followed in the absence of local code requirements.

This stove must be connected to a chimney complying with the requirements for Type HT chimneys in the Standard for Factory-Built Chimneys for Residential Type and Building Heating Appliances, UL 103 and ULC S629 or to a code-approved masonry chimney with a flue liner.

## 7 CLEARANCES TO COMBUSTIBLE MATERIAL

The clearances shown in this section have been determined by test according to procedures set out in safety standards ULC S627 (Canada), UL1482 (U.S.A.) and UL737 (U.S.A.). When the stove is installed so that its surfaces are at or beyond the minimum clearances specified, combustible surfaces will not overheat under normal and even abnormal operating conditions.

**No part of the stove or flue pipe may be located closer to combustibles than the minimum clearance figures given.**

### 7.1 LOCATION OF THE CERTIFICATION LABEL

Since the information given on the certification label affixed to the appliance always overrides the information published, in any other media (owner's manual, catalogues, flyers, magazines and/or web sites) it is important to refer to it in order to have a safe and compliant installation. In addition, you will find information about your stove (model, serial number, etc.). You can find the certification label on the back of the stove.

*Napoleon Home Inspections*

## 7.2 CLEARANCES TO WALLS AND CEILING

The clearances to combustible walls may be slightly different in Canada and the U.S.A. and may also differ depending on whether you use single or double wall flue pipe. Please be sure to choose the *correct clearance for your location and type of flue pipe. See figure Clearances to combustible materials and floor protection to match each letter to a clearance.*

| APPLIANCE CLEARANCES<br>(INSTALLATION WITH SINGLE WALL<br>PIPE CONNECTOR) |               |               |
|---|---------------|---------------|
|   | CANADA        | USA           |
| A   | 15" (381 mm)) | 15" (381 mm)) |
| B   | 17" (432 mm)  | 17" (432 mm)  |
| C   | 10" (254 mm)  | 10" (254 mm)  |
| K   | 48" (1220 mm) | 48" (1220 mm) |
| L   | 84" (213 cm)  | 84" (213 cm)  |

| APPLIANCE CLEARANCES<br>(INSTALLATION WITH DOUBLE WALL<br>PIPE CONNECTOR) |               |               |
|---|---------------|---------------|
|   | CANADA        | USA           |
| A   | 6" (152 mm)   | 6" (152 mm)   |
| B   | 17" (432 mm)  | 17" (432 mm)  |
| C   | 5" (127 mm)   | 5" (127 mm)   |
| K   | 48" (1220 mm) | 48" (1220 mm) |
| L   | 84" (213 cm)  | 84" (213 cm)  |

If the above clearances are met, then the distances measured from the flue outlet will be:

| DISTANCES* FROM PIPE CONNECTOR<br>TO THE COMBUSTIBLE MATERIALS |               |               |
|--|---------------|---------------|
|  | CANADA        | USA           |
| D  | 18½" (470 mm) | 18½" (470 mm) |
| E  | 27½" (699 mm) | 27½" (699 mm) |
| F  | 20" (508 mm)  | 20" (508 mm)  |

| DISTANCES* FROM PIPE CONNECTOR<br>TO THE COMBUSTIBLE MATERIALS |               |               |
|--|---------------|---------------|
|  | CANADA        | USA           |
| D  | 9½" (241 mm)  | 9½" (241 mm)  |
| E  | 27½" (699 mm) | 27½" (699 mm) |
| F  | 15" (381 mm)  | 15" (381 mm)  |

\*The pipe distances listed in this table refer to the distances obtained when the stove is installed in accordance with the appliance clearances above mentioned. However, you can install the stove at reduced clearances; follow the instructions in Section 7.4: *Reducing Wall and Ceiling Clearances Safely*. Where they are followed, the new distance of the pipe to combustible materials must be respected in the appropriate certification of the pipe.

**Clearances with ceiling (L) lowered to 76" (193 cm)**

|          | APPLIANCE CLEARANCES<br>(INSTALLATION WITH SINGLE WALL<br>PIPE CONNECTOR) |               |
|----------|---|---------------|
|          | CANADA  | USA           |
| <b>A</b> | 15" (381 mm))   | 15" (381 mm)) |
| <b>B</b> | 17" (432 mm)  | 17" (432 mm)  |
| <b>C</b> | 14" (356 mm)  | 14" (356 mm)  |
| <b>K</b> | 48" (1220 mm)   | 48" (1220 mm) |
| <b>L</b> | 76" (193 cm)  | 76" (193 cm)  |

|          | APPLIANCE CLEARANCES<br>(INSTALLATION WITH DOUBLE WALL<br>PIPE CONNECTOR) |               |
|----------|---|---------------|
|          | CANADA  | USA           |
| <b>A</b> | 8" (203 mm)   | 8" (203 mm)   |
| <b>B</b> | 17" (432 mm)  | 17" (432 mm)  |
| <b>C</b> | 9" (229 mm)   | 9" (229 mm)   |
| <b>K</b> | 48" (1220 mm)   | 48" (1220 mm) |
| <b>L</b> | 76" (193 cm)  | 76" (193 cm)  |

If the above clearances are met, then the distances measured from the flue outlet will be:

|          | DISTANCES* FROM PIPE CONNECTOR<br>TO THE COMBUSTIBLE MATERIALS |               |
|----------|--|---------------|
|          | CANADA   | USA           |
| <b>D</b> | 18½" (470 mm)  | 18½" (470 mm) |
| <b>E</b> | 27½" (699 mm)  | 27½" (699 mm) |
| <b>F</b> | 24" (610 mm)   | 24" (610 mm)  |

|          | DISTANCES* FROM PIPE CONNECTOR<br>TO THE COMBUSTIBLE MATERIALS |               |
|----------|--|---------------|
|          | CANADA   | USA           |
| <b>D</b> | 11½" (292 mm)  | 11½" (292 mm) |
| <b>E</b> | 27½" (699 mm)  | 27½" (699 mm) |
| <b>F</b> | 19" (483 mm)   | 19" (483 mm)  |

\*The pipe distances listed in this table refer to the distances obtained when the stove is installed in accordance with the appliance clearances above mentioned. However, you can install the stove at reduced clearances; follow the instructions in Section 7.4: *Reducing Wall and Ceiling Clearances Safely*. Where they are followed, the new distance of the pipe to combustible materials must be respected in the appropriate certification of the pipe.

**Clearances for mobile homes**

| MOBILE HOME APPLIANCE CLEARANCES (INSTALLATION WITH DOUBLE WALL PIPE CONNECTOR) |               |               |
|---|---------------|---------------|
|   | CANADA        | USA           |
| <b>A</b>  | 14" (356 mm)  | 14" (356 mm)  |
| <b>B</b>  | 19" (483 mm)  | 19" (483 mm)  |
| <b>C</b>  | 13" (330 mm)  | 13" (330 mm)  |
| <b>K</b>  | 48" (1220 mm) | 48" (1220 mm) |
| <b>L</b>  | 84" (213 cm)  | 84" (213 cm)  |

If the above clearances are met, then the distances measured from the flue outlet will be:

| DISTANCES* FROM PIPE CONNECTOR TO THE COMBUSTIBLE MATERIALS |               |               |
|---|---------------|---------------|
|   | CANADA        | USA           |
| <b>D</b>  | 17½" (445 mm) | 17½" (445 mm) |
| <b>E</b>  | 29½" (749 mm) | 29½" (749 mm) |
| <b>F</b>  | 23" (584 mm)  | 23" (584 mm)  |

\*The pipe distances listed in this table refer to the distances obtained when the stove is installed in accordance with the appliance clearances above mentioned. However, you can install the stove at reduced clearances; follow the instructions in Section 7.4: *Reducing Wall and Ceiling Clearances Safely*. Where they are followed, the new distance of the pipe to combustible materials must be respected in the appropriate certification of the pipe.



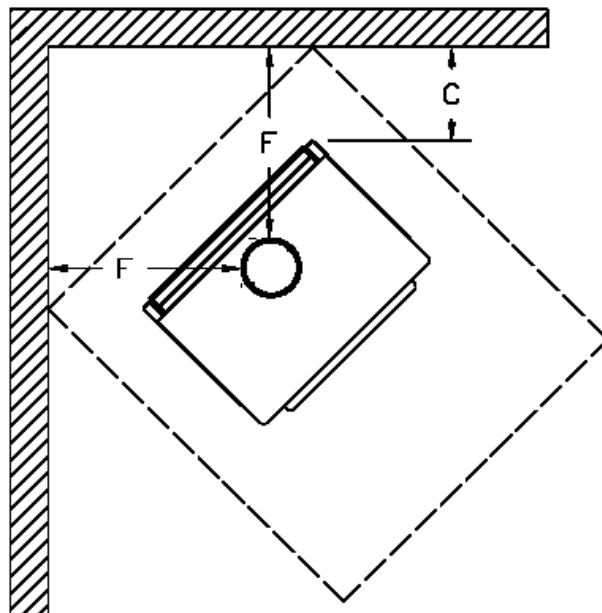
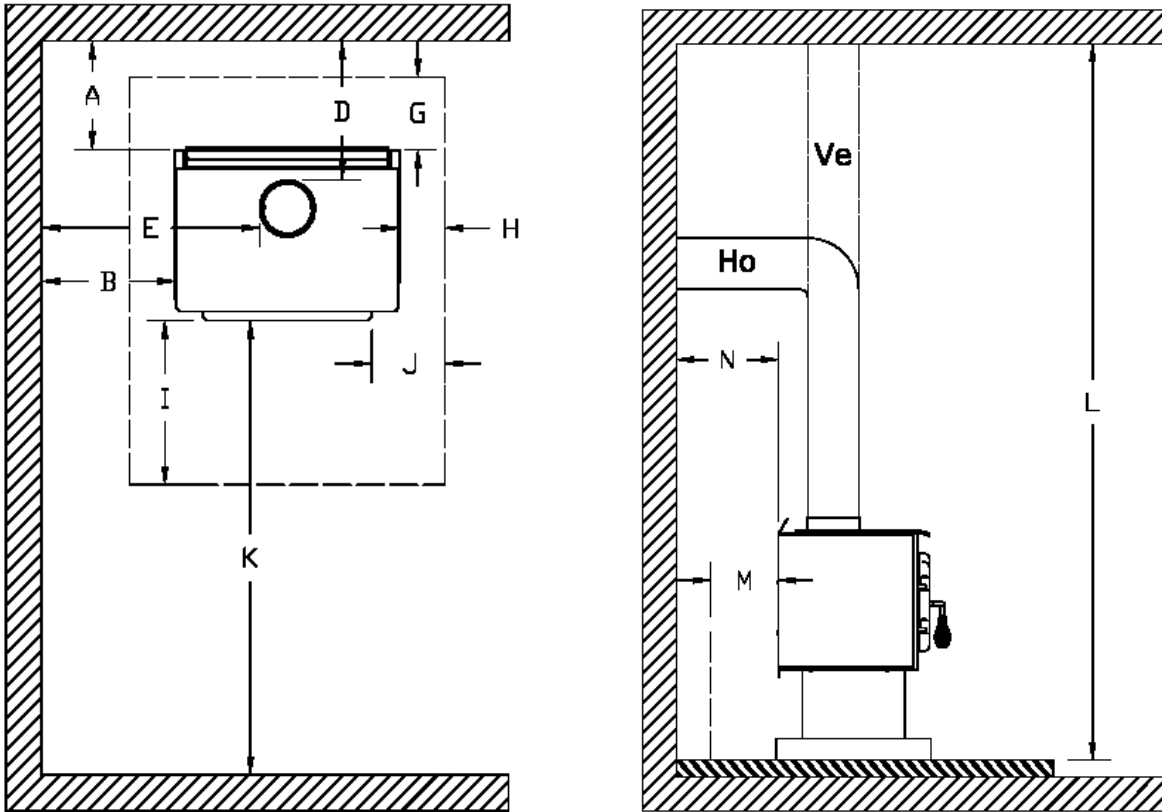

Clearances to combustible materials and floor protection

### 7.3 FLOOR PROTECTOR

If the stove is to be installed on top of a combustible floor, it must be guarded by a non combustible material as shown on figure **Clearances to combustible materials and floor protection** (see the dotted line area).

| FLOOR PROTECTOR* |                                   |                                   |
|------------------|-----------------------------------|-----------------------------------|
|                  | CANADA                            | USA                               |
| <b>G</b>         | 8" (203 mm) – Note 1              | N/A (Canada only)                 |
| <b>H</b>         | 8" (203 mm)                       | N/A (Canada only)                 |
| <b>I</b>         | 18" (457 mm)<br>From door opening | 16" (406 mm)<br>From door opening |
| <b>J</b>         | N/A (USA only)                    | 8" (203 mm)                       |
| <b>M</b>         | 8" (203 mm)                       | N/A (Canada only)                 |
| <b>N</b>         | N/A (USA only)                    | Note 2                            |

\*Steel with a minimum thickness of 0.015" (0.38 mm) or ceramic tiles sealed together with grout. No protection is required if the unit is installed on a non-combustible floor (ex: concrete).

**Note 1:** The floor protection at the back of the stove is limited to the stove's required clearance if such clearance is smaller than 8 inches (203 mm).

**Note 2:** Only required under the horizontal section of the connector. Must exceed each side of the connector by at least 2 inches (51 mm).

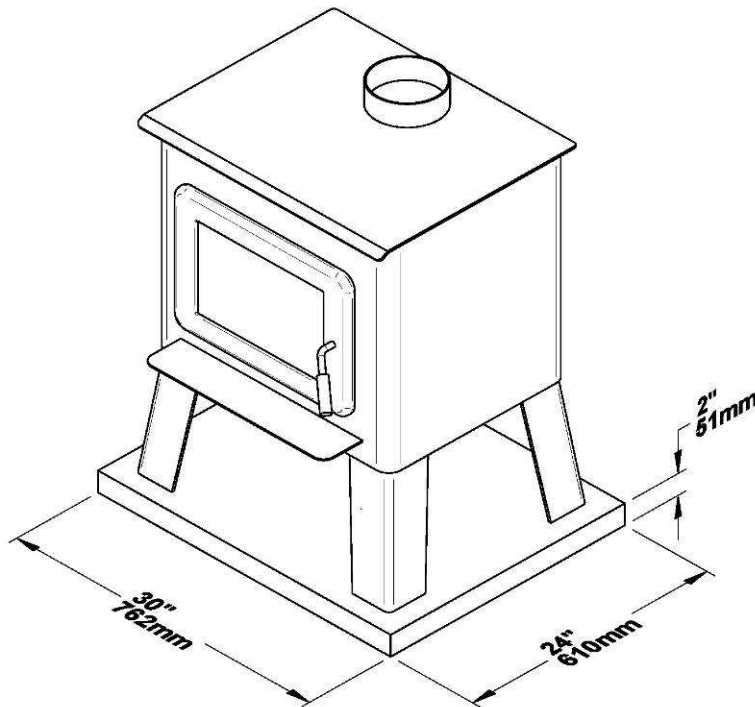

**Important Note:** Addition required to the floor protection when the stove is installed in a mobile home and assembled on legs version only:

In addition to meeting the minimum size of the floor protection, the stove must be placed on a podium having a maximum dimension of 30" (762 mm) x 24" (610 mm) and a minimum height of 2" (51 mm). This podium can be constructed of combustible materials as long as it is covered of non-combustible materials. See figure beside.

## 7.4 REDUCING WALL AND CEILING CLEARANCES SAFELY

It is often desirable to reduce the minimum installation clearances by placing the stove closer to walls so the installation takes up less floor space. You can safely reduce the minimum clearances by permanently installing a shield between the stove and combustible material. The rules for safe shields can be complicated, so read them carefully and follow them exactly. Note that there may be minor regional differences in clearance reduction rules so be sure to check with your building or fire inspector before proceeding.

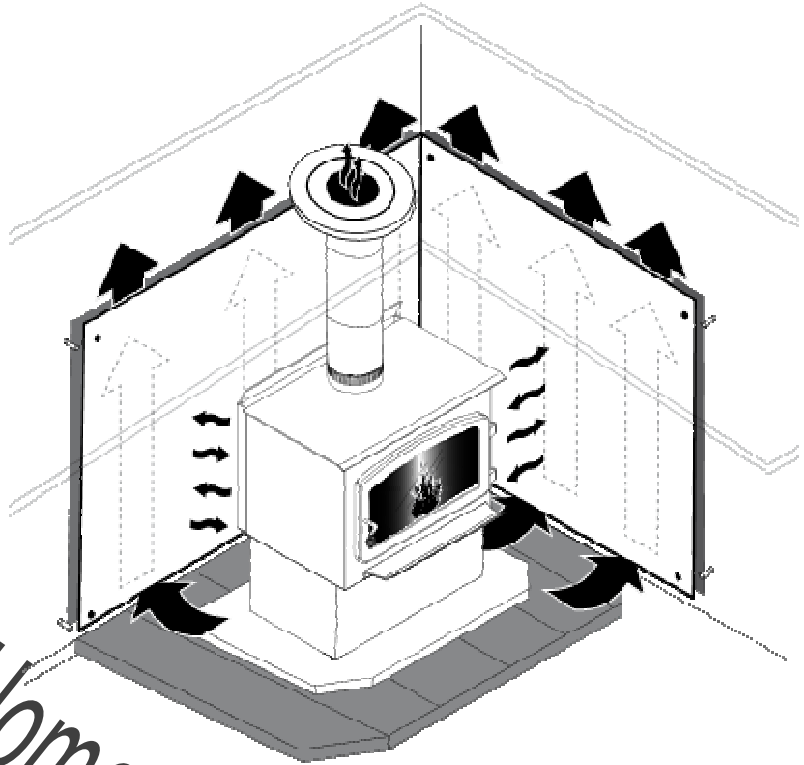

### 7.4.1 SHIELD CONSTRUCTION RULES

See figure *Clearances for shield construction* to match each letter to a clearance.

- Adhesives used in shield construction must not ignite or lose adhesive qualities at temperatures likely to be encountered.
- Mounting hardware which extends from the shield surface into combustibles may be used only at the edges of the shield.
- Mounting hardware must allow full vertical ventilation.

**A** Minimum clearance between the appliance top and an unshielded combustible ceiling: 1143 mm (45 in.).

**B** Shield extension above appliance: 500 mm (20 in.).

**C** Minimum space behind shield: 25 mm (1 in.). In Canada 21 mm (7/8 in.).

**D** Clearance along the bottom of shield: minimum: 25 mm (1 in.) and maximum: 75 mm (3 in.).

**E** Minimum clearance along the top of shield at ceiling: 75 mm (3 in.).

**F** Mounting hardware must not be located closer than 200 mm (8 in.) from the vertical centre line of the appliance.

**G** Edge clearance for ceiling shields to side and back walls: 75 mm (3 in.).

**H** Shield extension beyond each side of appliance: 450 mm (18 in.).

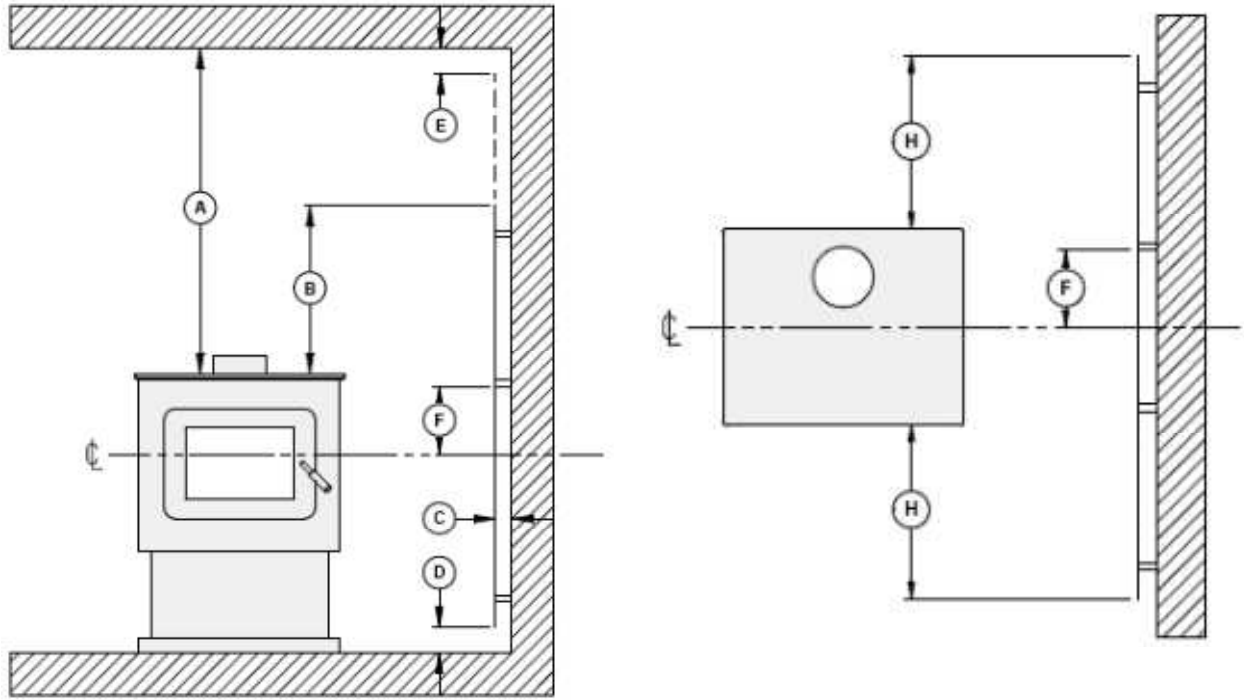

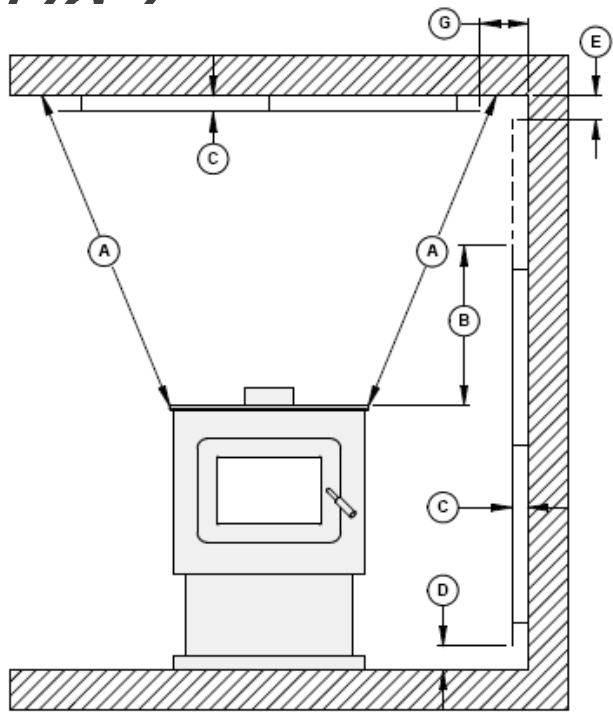

Clearances

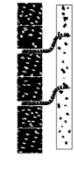

Clearances for shield construction

7.4.2 TABLE OF CLEARANCE REDUCTION PERCENTAGES

| Type of shield   | Clearances may be reduced by these percentages |          |                 |          |    |
|--|--|----------|-----------------|----------|---|
|  | Sides and rear %                               |          | Top % (ceiling) |          |   |
|  | Can/USA (%)                                    | USA min. | Can/USA (%)     | USA min. |   |
| Sheet metal, a minimum of 24 gauge (0.61 mm) in thickness , spaced out at least 25 mm (1 in)* by non-combustible spacers   | 67   | 12 in    | 50              | 18 in    |    |
| Ceramic tiles or equivalent non-combustible material, on non-combustible board spaced out at least 25 mm (1 in)* by non-combustible spacers  | 50   | 18 in    | 33              | 24 in    |  |
| Ceramic tiles, or equivalent non-combustible material, on non-combustible board, with a minimum of 24 gauge (0.61 mm) sheet metal backing spaced out at least 25 mm (1 in)* by non-combustible spacers | 67   | 12 in    | 50              | 24 in    |  |
| Brick, spaced out at least 25 mm (1 in)* by non-combustible spacers  | 50   | 18 in    | N/A             | N/A      |  |
| Brick, with a minimum of 24 gauge (0.61 mm) sheet metal backing, spaced out at least 25 mm (1 in)* by non-combustible spacers  | 67   | 12 in    | N/A             | N/A      |  |

\* In Canada this space can be 21 mm (7/8 in).

## 8 THE VENTING SYSTEM

### 8.1 GENERAL

The venting system, made up of the chimney and the connecting pipe between the stove and the chimney, acts as the engine that drives your wood heating system. Even the best stove will not function safely and efficiently as intended if it is not connected to a suitable chimney.

The heat in the flue gases that pass from the stove and chimney connector into the chimney is not waste heat. This heat is what the chimney uses to make the draft that draws in combustion air, keeps smoke inside the stove and safely vents exhaust to outside. You can think of heat in the flue gas as the fuel the chimney uses to make draft.

### 8.2 SUITABLE CHIMNEYS

Your wood stove will provide optimum efficiency and performance when connected to a 6-inch diameter chimney flue system. The connection to a chimney having a diameter of at least 5 inches (Canada only) or no more than 7 inches is permitted, if it allows the proper venting of combustion gases and that such application is verified and authorized by a qualified installer. Otherwise, the diameter of the flue should be 6 inches.

To be suitable, a factory-built metal chimney must comply with UL 103 (U.S.A.) or ULC S629 (Canada).

#### 8.2.1 FACTORY-BUILT METAL CHIMNEYS

These are sometimes referred to as 'high temp' chimneys because they have the special characteristics to withstand the temperatures that can be created by wood burning stoves. Factory-built chimneys are tested as a system with all the necessary components for installation. The instructions provided with the chimney by its manufacturer are the only reliable source of installation guidelines. To be safe and effective, the chimney must be installed exactly in accordance with the manufacturer's instructions. **Use only components intended for the brand and model of chimney you are using. Never substitute parts from other chimney brands or fabricate your own components. The chimney must be a type suitable for solid fuel.**

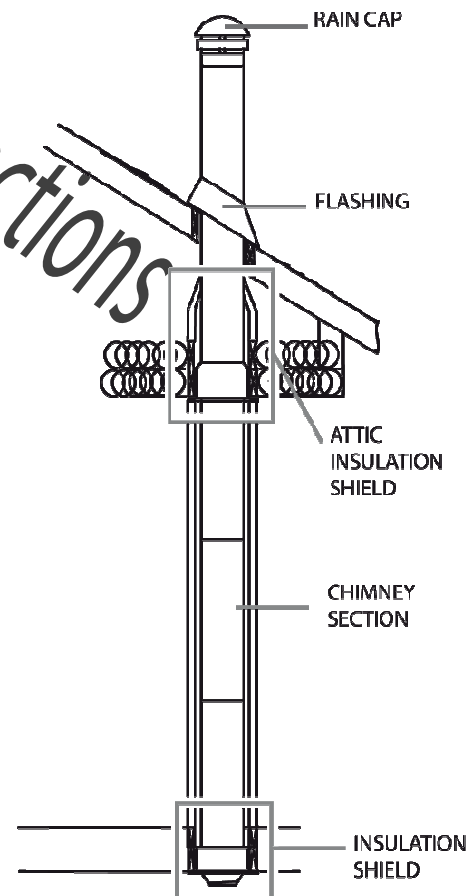

### 8.2.2 FACTORY-BUILT METAL CHIMNEYS IN MOBILE HOMES

For use in a mobile home, this stove is to be connected to a 6" in diameter double wall factory built chimney conforming to CAN/UCL-S629, Standards for 650°C Factory-built chimney. The total length of the flue system should be at least 12 feet including elbows, from the top of the stove.

To maintain an effective vapour barrier, insulation and waterproof at the chimney and outside flue pipe, install a mobile home roof flashing and seal it with silicone.

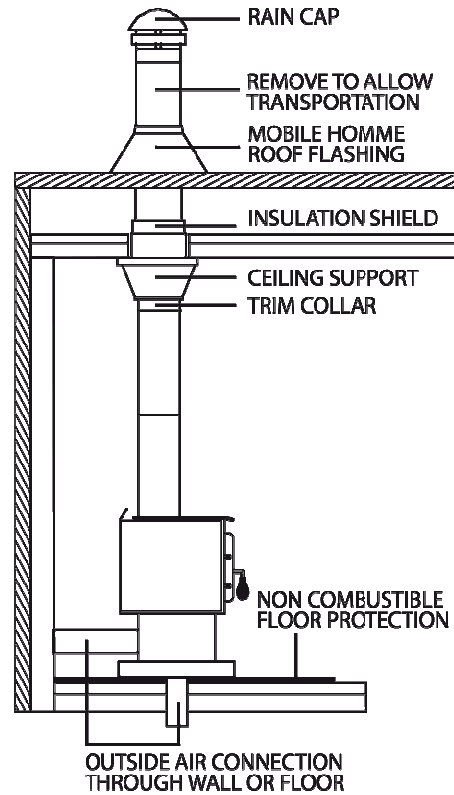

### 8.2.3 MASONRY CHIMNEYS

The stove may also be connected to a masonry chimney, provided the chimney complies with the construction rules found in the building code enforced locally. The chimney must have either a clay liner or a suitably listed stainless steel liner. If the masonry chimney has a square or rectangular liner that is larger in cross sectional area than a round 6" flue, it should be relined with a suitably listed 6" stainless steel liner. Do not downsize the flue to less than 6" unless the venting system is straight and exceeds 25 feet in height. When passing through a combustible wall, the use of an insulated listed thimble is required.

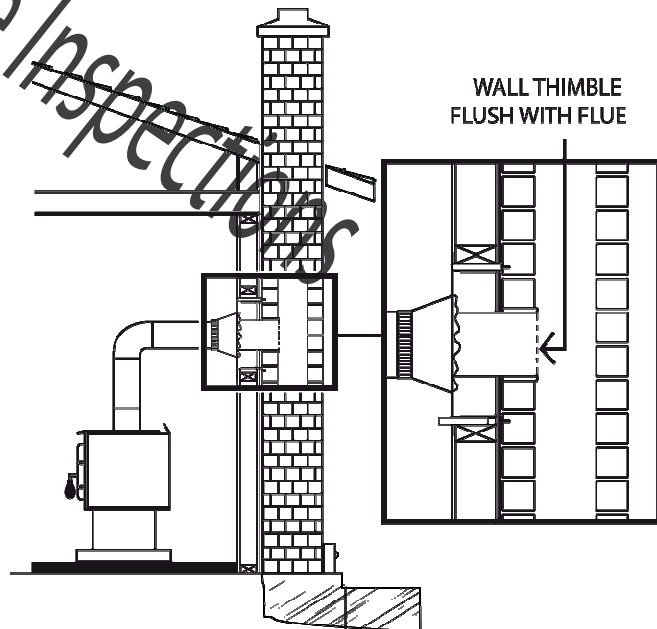

### 8.3 MINIMUM CHIMNEY HEIGHT

The top of the chimney should be tall enough to be above the air turbulence caused when wind blows against the house and its roof. The chimney must extend at least 1 m (3 ft.) above the highest point of contact with the roof, and at least 60 cm (2 ft.) higher than any roof line or obstacle within a horizontal distance of 3 m (10 ft.).

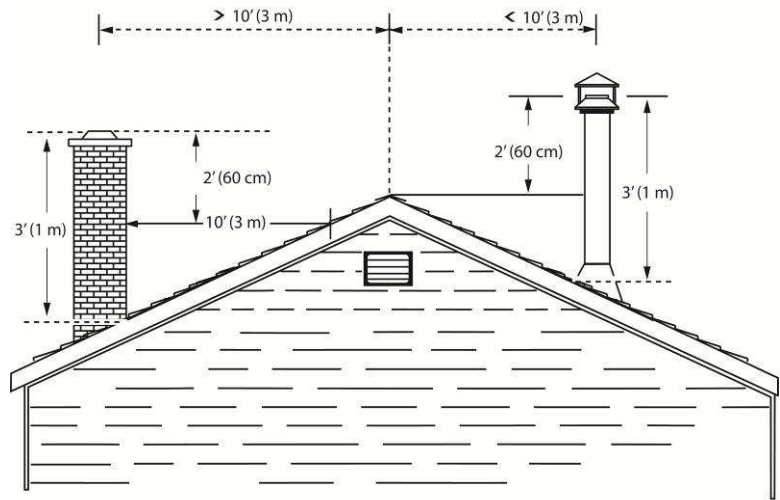

### 8.4 THE RELATIONSHIP BETWEEN THE CHIMNEY AND THE HOUSE

Because the venting system is the engine that drives the wood heating system, it must have the right characteristics. The signs of bad system design are cold backdrafting when there is no fire in the stove, slow kindling of new fires, and smoke roll-out when the door is opened for loading. There are two guidelines to follow. First, the chimney should be installed up through the heated space of the house, not out and up an outside wall. Second, the chimney should penetrate the top of the building at or near the highest heated space.

#### 8.4.1 WHY INSIDE CHIMNEYS ARE PREFERRED

Venting systems that rise straight up from the stove flue collar provide the best performance. Chimneys that rise inside the warm space of the house tend to provide a small amount of draft even when there is no fire burning. This means that when you light a fire, the initial smoke goes up the chimney and strong draft builds quickly as the chimney flue warms up. Although they are common in North America, chimneys that exit a house wall and run up outside can cause problems.



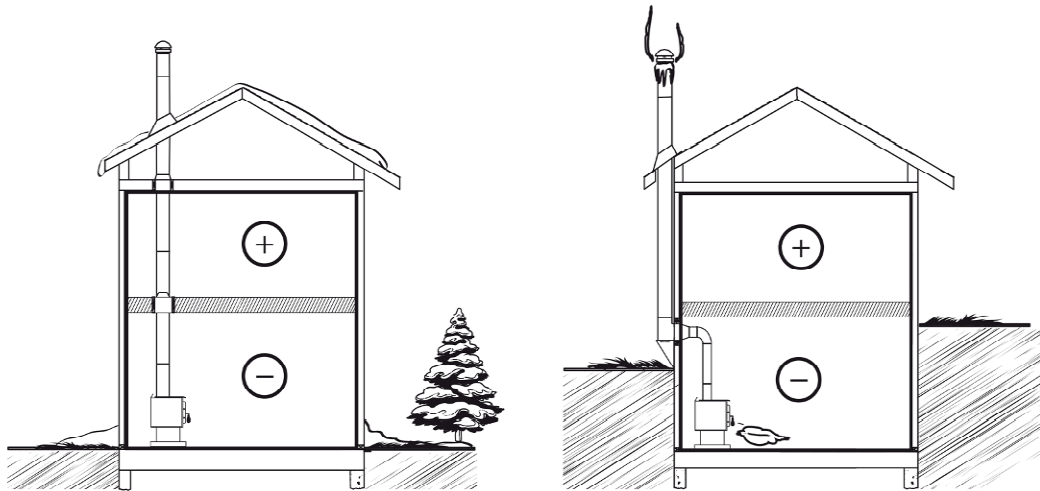

#### Good System Design

Inside chimneys are preferred because even when no fire is burning, there is normally upward flow in the system.

#### Inferior System Design

Outside chimneys are a problem because when no fire burns they will go into cold backdraft if the stove is installed low in the house.

### 8.4.2 WHY THE CHIMNEY SHOULD PENETRATE THE HIGHEST HEATED SPACE

When it is cold outside, the warm air in the house is buoyant so it tends to rise. This tendency of warm air to rise creates a slight pressure difference in the house. Called 'stack effect', it produces a slightly negative pressure low in the house (relative to outside) and a slightly positive pressure zone high in the house. If there is no fire burning in a heater connected to a chimney that is shorter than the warm space inside the house, the slight negative pressure low in the house will compete against the desired upward flow in the chimney.

There are two reasons why the chimney in the house at right will cold backdraft when it is cold outside and there is no fire burning in the stove. First, the chimney runs up the outside of the house, so the air in it is colder and denser than the warm air in the house. And second, the chimney is shorter than the heated space of the house, meaning the negative pressure low in the house will pull outside air down the chimney, through the stove and into the room. Even the finest stove will not work well when connected to this chimney.



## 8.5 SUPPLY OF COMBUSTION AIR

In Canada, wood stoves are not required to have a supply of combustion air from outdoors (except in mobile homes) because research has shown that these supplies do not give protection against house depressurization and may fail to supply combustion air during windy weather. However, to protect against the risk of smoke spillage due to house depressurization, **a carbon monoxide (CO) detector/alarm is required** in the room in which the stove is installed. The CO detector will provide warning if for any reason the wood stove fails to function correctly.

### 8.5.1 COMBUSTION AIR SUPPLY IN MOBILE HOMES

**Only a wood stove certified and labelled as 'mobile home approved' may be installed in a mobile home.** This Osburn 2000 stove is 'mobile home approved'. Wood stoves installed in mobile homes must have a ducted supply of combustion air from outdoors. This air supply should be routed down through the house floor into the vented crawl space under the mobile home. The air supply duct should be non-combustible aluminum flex duct with a screened weatherhood on the outside end.

Note: Fabric duct may also be used, provided it is suitable for HVAC use and meets the requirements of ULC-S210 or UL-181 Class 1 standards. It must have a non-combustible insulation and be corrosion resistant.

Where a mobile home has been converted to a standard house by mounting it on a permanent basement foundation, the supply of outdoor air is not required.

### 8.5.2 AIR SUPPLY IN CONVENTIONAL HOUSES

The safest and most reliable supply of combustion air for your wood stove is from the room in which it is installed. Room air is already preheated so it will not chill the fire, and its availability is not affected by wind pressures on the house. Contrary to commonly expressed concerns, almost all tightly-sealed new houses have enough natural leakage to provide the small amount of air needed by the stove. The only case in which the wood stove may not have adequate access to combustion air is if the operation of a powerful exhaust device (such as a kitchen range exhaust) causes the pressure in the house to become negative relative to outdoors.

Some jurisdictions in the United States require that wood stoves have a supply of combustion air from outdoors. If you do install an air supply through the wall of the house, be aware that its pressure can be affected during windy weather. If you notice changes in wood stove performance in windy weather, and in particular if smoke puffs from the stove, you should disconnect the outdoor air duct from the stove and remove the duct. In some windy conditions, negative pressure at the duct weatherhood outside the house wall may draw hot exhaust gases from the stove backwards through the duct to outdoors. Check the outdoor air duct for soot deposits when the full system is cleaned and inspected at least once each year.

## 8.6 INSTALLING THE CHIMNEY CONNECTOR

The chimney connector is the single or double wall pipe installed between the stove flue collar and the chimney breech. Single wall pipe components are available from most hardware and building supply stores. These components are not usually tested to a particular standard and certified as compliant. Therefore, a list of rules found in solid fuel installation codes apply to the installation of single wall pipe.

Double wall chimney connectors are tested and certified. The rules for double wall pipe are found in the manufacturer's installation instructions. These rules will be very different than those for single wall.

### 8.6.1 INSTALLATION OF SINGLE WALL CHIMNEY CONNECTOR

The chimney connector assembly has been called 'the weak link' in the safety of wood heating systems because failure to install the connector properly (which has been common in the past) can result in house fires.

The best flue pipe assembly is one that rises straight up from the stove to the base of the chimney with no elbows. Straight assemblies are less likely to cause problems like smoke roll-out when the door is opened for loading. They are also more stable and easier to maintain than assemblies with elbows. Horizontal runs of flue pipe should be avoided where possible because they reduce chimney draft.

*Napoleon Home Inspections*

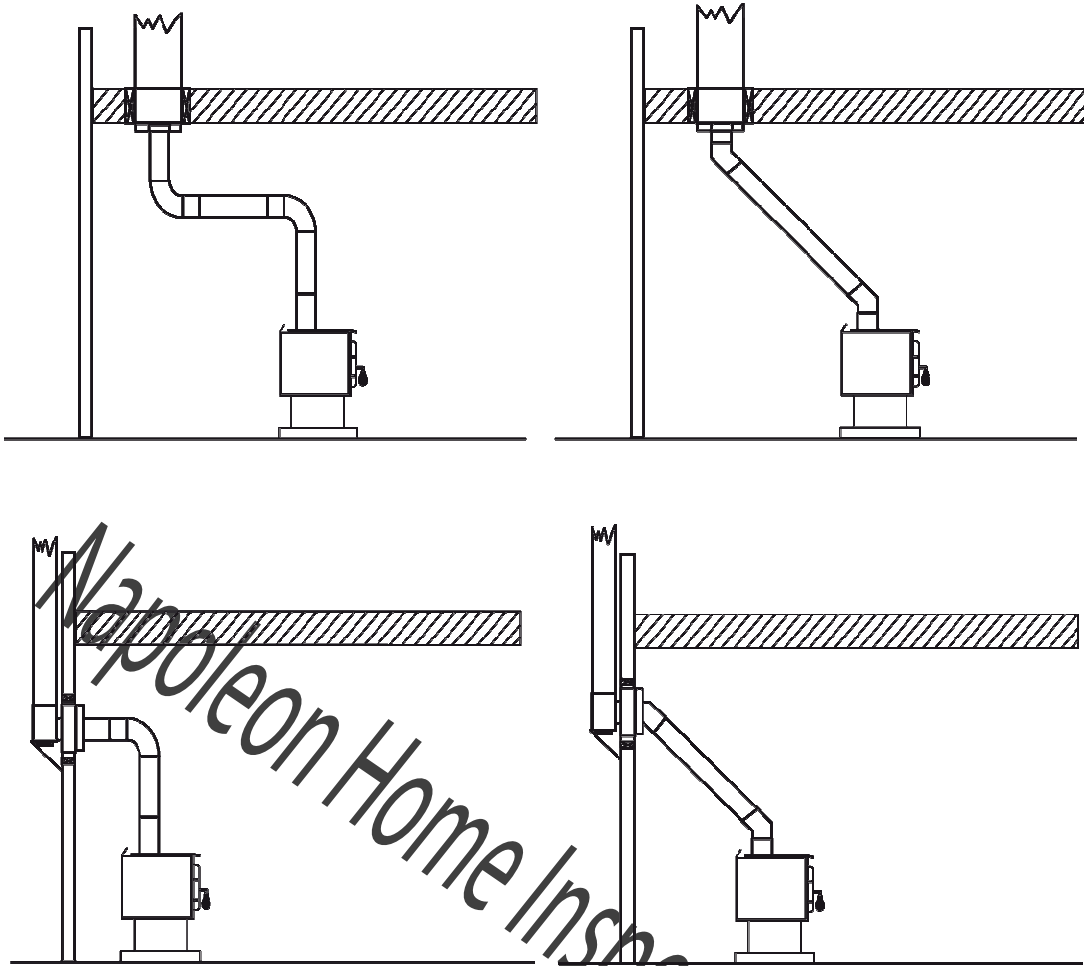

*Use 45 degree elbows where possible, instead of 90 degree elbows.*

The rules below are based on those found in the CSA B365 installation code. Please carefully follow these installation instruction rules, or those enforced where you live.

- Maximum overall length of straight pipe: 3 m (10 ft.) including elbows.
- Minimum clearance from combustible material: 450 mm (18 in.). The minimum clearance may be reduced by 50 percent to 225 mm (9 in.) if suitable shielding is installed either on the pipe or on the combustible surface.
- The assembly should be as short and direct as possible between the stove and chimney. The use of two 45 degree elbows is often preferable to a single 90 degree elbow because less turbulence is created in the exhaust flow and they result in less horizontal run.
- Maximum number of 90-degree elbows: 2.
- Maximum unsupported horizontal length: 1 m (3 feet).
- Galvanized flue pipes must not be used because the coatings vaporize at high temperatures and release dangerous gases. Use black painted flue pipes.
- Flue pipes must be at least 24 gauge in thickness.
- Flue pipe joints should overlap 30 mm (1 1/4 in.)
- Each joint in the assembly must be fastened with at least three screws.
- The assembly must have allowance for expansion: elbows in assemblies allow for expansion; straight assemblies should include an inspection wrap with one end unfastened, or a telescopic section.
- Minimum upward slope towards the chimney: 20 mm/m (1/4 in/ft.).
- One end of the assembly must be securely fastened to the flue collar with 3 sheet metal screws and the other end securely fastened to the chimney.
- There must be provision for cleaning of the pipes, either through a clean out or by removal of the pipe assembly. Removal of the assembly should not require that the stove be moved.
- The male ends of the sections must be oriented towards the appliance so that falling dust and condensation stay inside the pipe.
- A flue pipe must never pass through a combustible floor or ceiling or through an attic, roof space, closet or concealed space.
- Where passage through a wall or partition of combustible construction is desired, the installation shall conform to CAN/CSA-B365, Installation Code for Solid-Fuel-Burning Appliances and Equipment.

The ideal flue pipe assembly is one that rises straight up from the appliance flue collar and directly into the chimney with no elbows. A straight up connector assembly needs either a telescopic length or an inspection wrap (pipe coupler) to allow it to be assembled and disassembled without moving the stove.

A straight flue pipe assembly offers the least restriction to gas flow and results in stronger draft. Straight assemblies also need less maintenance because there are no corners to collect creosote.

The chimney connector must be in good condition.

## APPENDIX 1: INSTALLING THE OPTIONAL LEGS OR PEDESTAL

### LEGS ASSEMBLY

In order to install the legs on your Osburn 2000 wood stove, follow these steps:

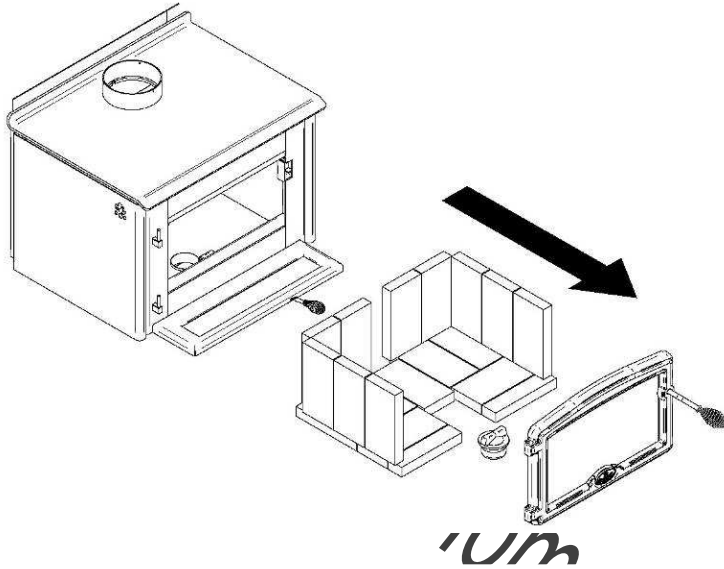

- 1- Remove the door, the firebricks and the cast iron ash plug from the stove.

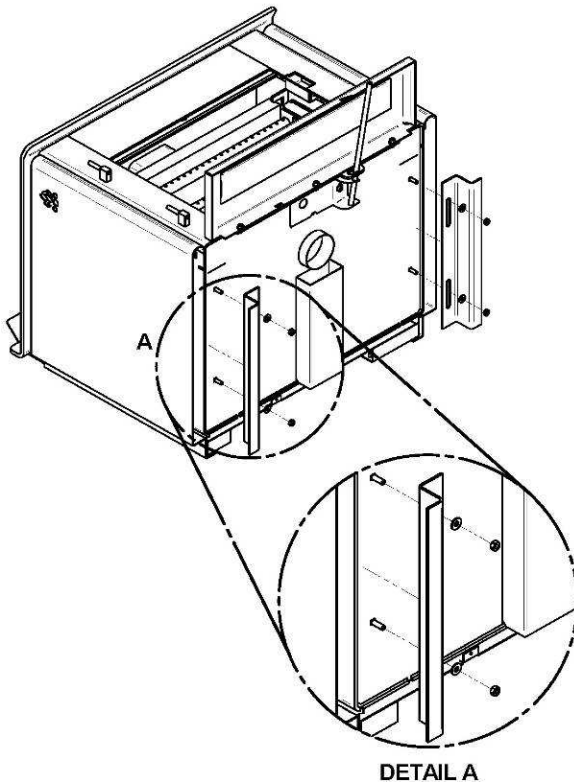

- 2- Put the stove on its back. Remove and dispose of the two freight supports. Keep the nuts and washers for step 4.

inspections

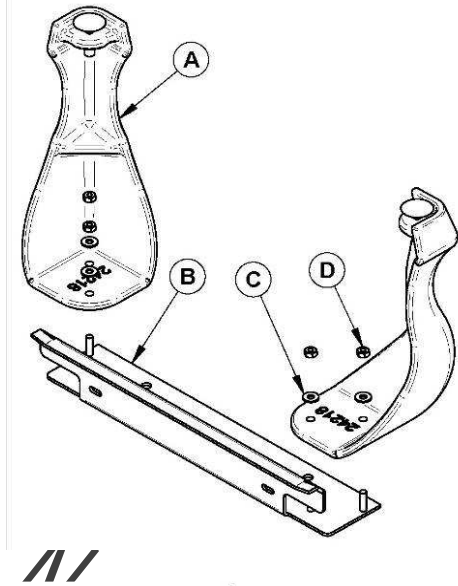

3- Secure the legs (A) to the legs supports (B) using two screws already installed on the legs supports. There are two screws per leg. Use the washers (C) and nuts (D) supplied with the leg assembly.

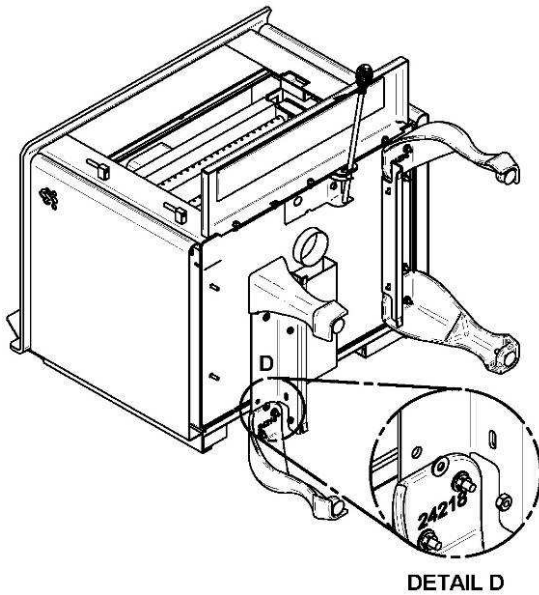

4- With the nuts and washers removed in step 1; secure both leg assemblies to the stove. There are two nuts and washers per leg assembly.

Inspections

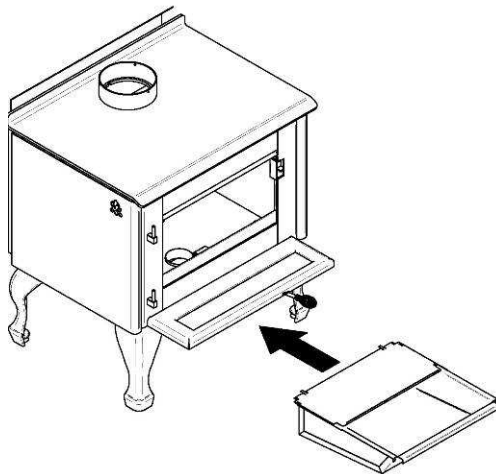

5- Put the stove on its legs and install the ash drawer included with the kit.

6- Put back the firebricks, the cast iron ash plug and the door on the stove.

## PEDESTAL ASSEMBLY

In order to install the pedestal on your Osburn 2000 wood stove, follow these steps:

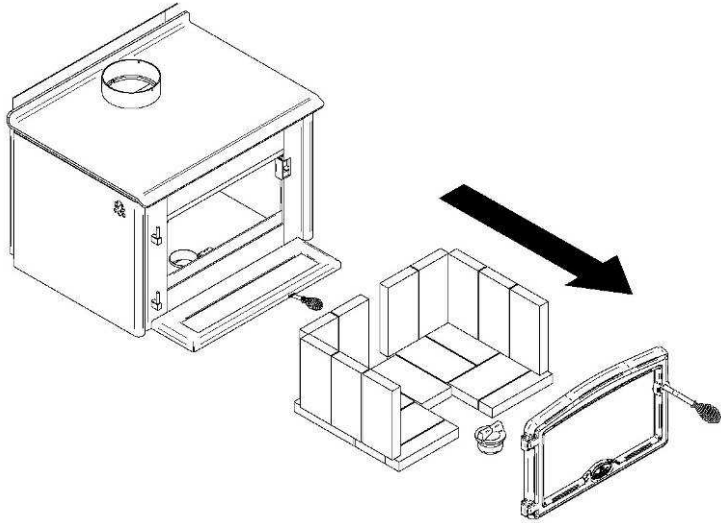

- 1- Remove the door, the firebricks and the cast iron ash plug from the stove.

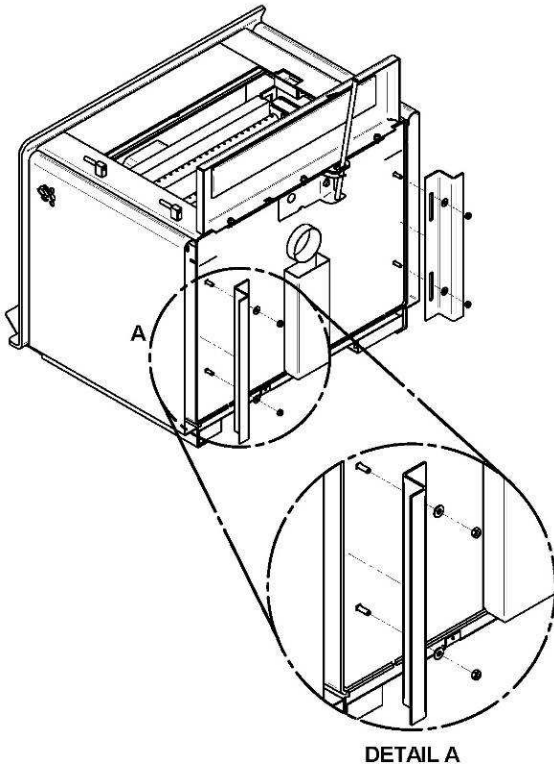

- 2- Put the stove on its back. Remove and dispose of the two freight supports. Keep the nuts and washers for step 3.



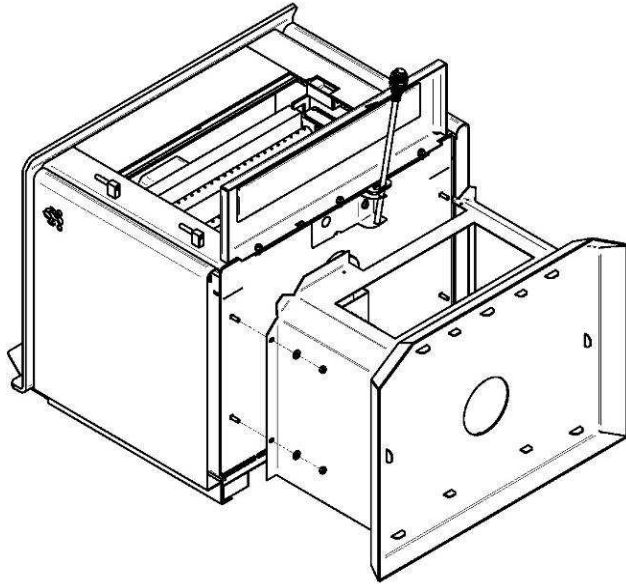

- 3- Secure the pedestal to the stove using the 4 screws already installed, with the nuts and washers kept from step 2. There are 4 places where the pedestal should be secured.

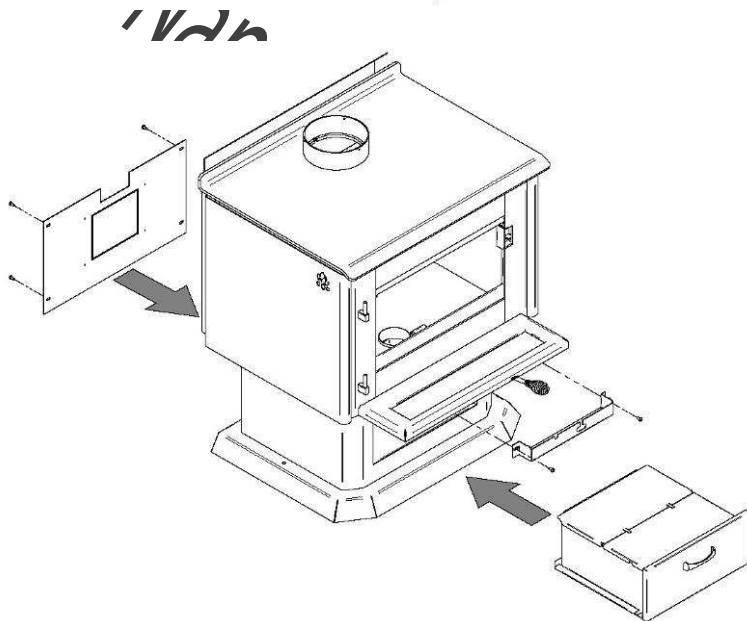

- 4- Put the stove on its pedestal and complete the installation by securing the fresh air rear panel, the front air control cover and by sliding in the ash drawer (all included in the kit).
- 5- Put back the firebricks, the cast iron ash plug and the door on the stove.

ctions

## APPENDIX 2: INSTALLING THE OPTIONAL DOOR OVERLAY

Your Osburn 2000 wood stove must be equipped with a door overlay (A). In order to install it, secure it to the door using 4 screws (B) (screws #8 – 32 x 5/8" pan quadrex, supplied with the owner's manual) as shown below.

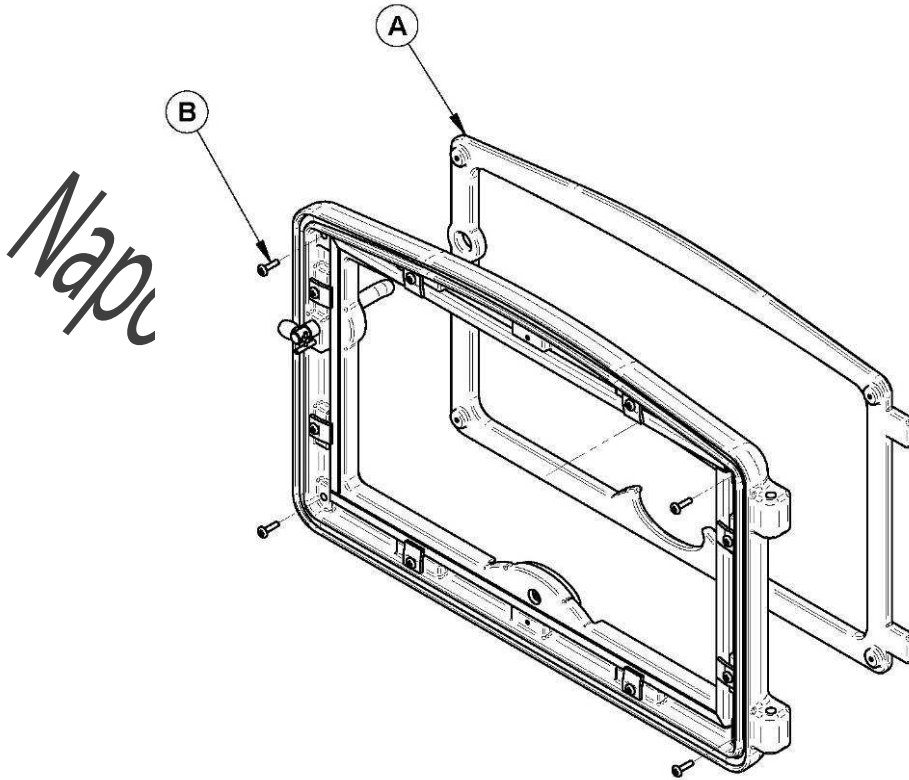

## APPENDIX 3: INSTALLING THE DECORATIVE PANELS

1. Start by fixing the front part of the decorative panel in the two clips welded on the sides of the fire box.
2. Then, fix the back of the decorative side with two screws and washers supplied. Line up the decorative sides parallel to the side of the appliance.

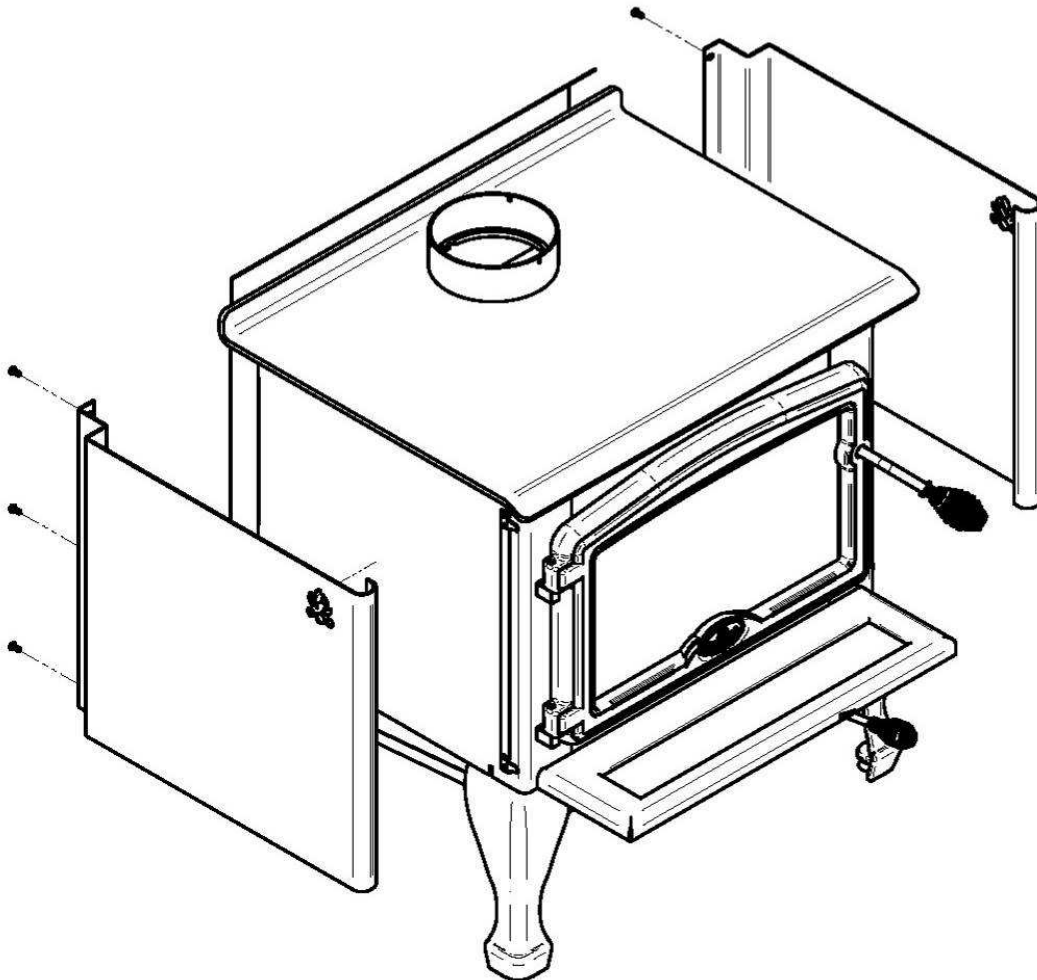

## APPENDIX 4: INSTALLING THE OPTIONAL FRESH AIR INTAKE KIT (AC01316 / AC01336)

This mobile home approved stove requires installation of a fresh air intake kit (A) and an insulated fresh air intake pipe (B), sold separately.

### INSTALLATION WITH LEGS (AC01316)

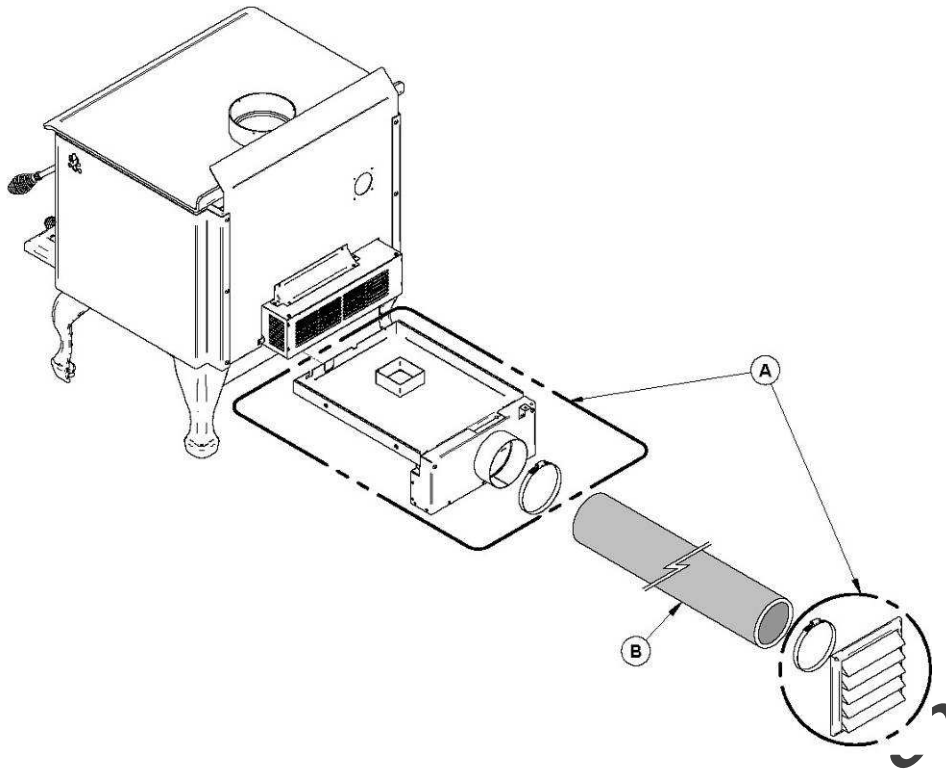

**INSTALLATION WITH PEDESTAL (AC01336)**

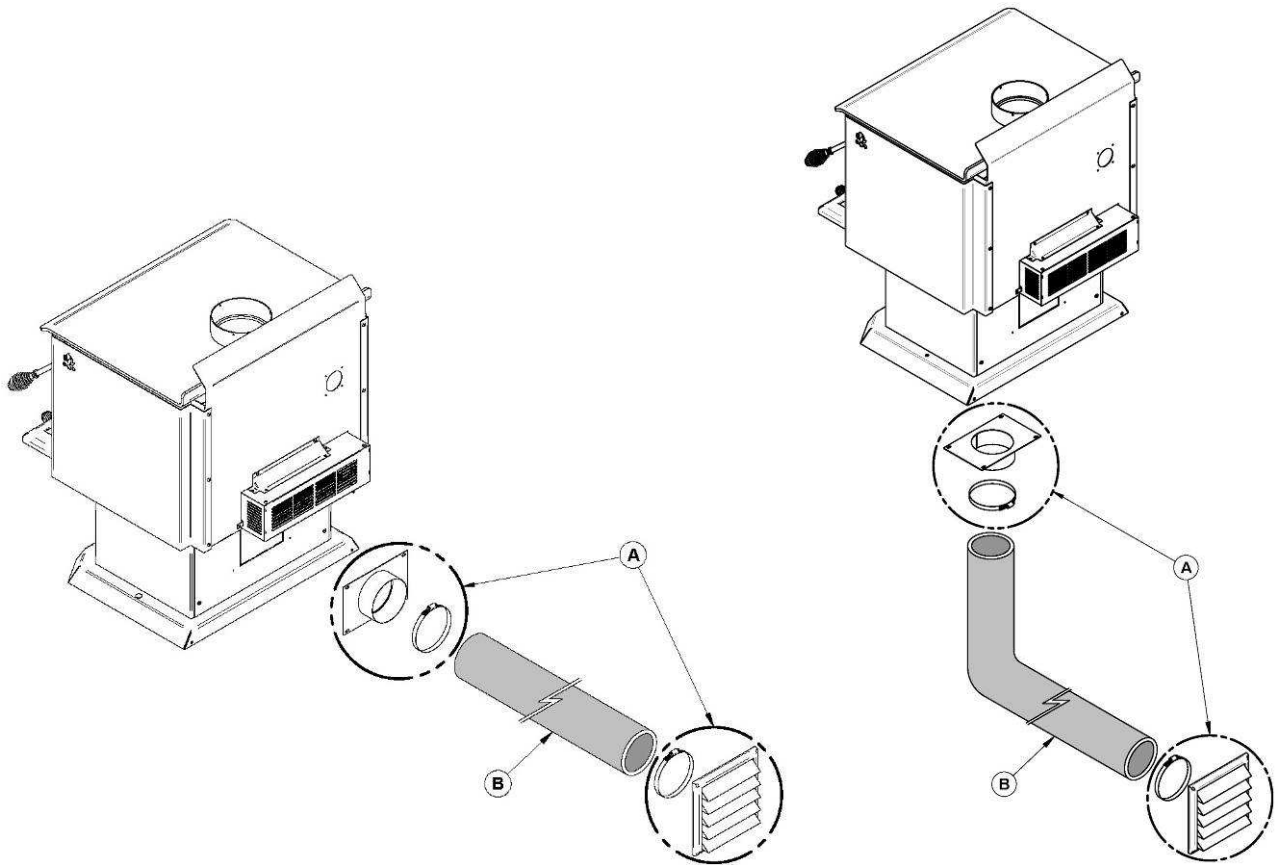

**Note:** If using a wood stove on a pedestal, refer to AC01336 manual for further information.

## APPENDIX 5: INSTALLING THE OPTIONAL FIRE SCREEN (AC01315)

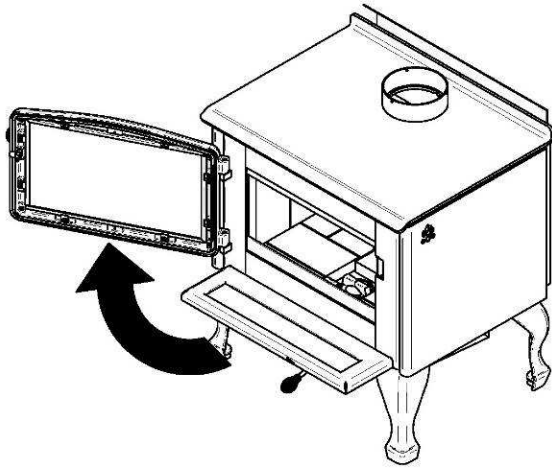

Open the door.

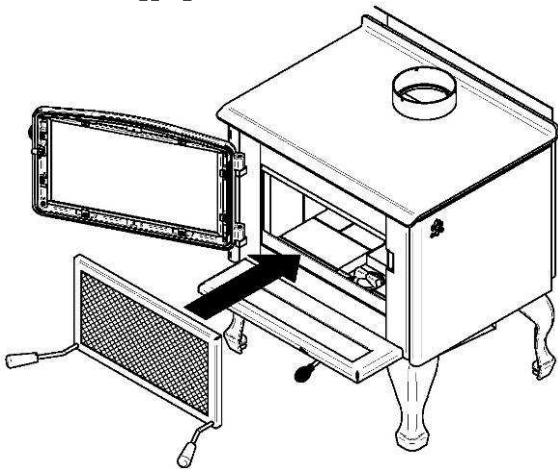

Hold the fire screen by the two handles and bring it close to the door opening.

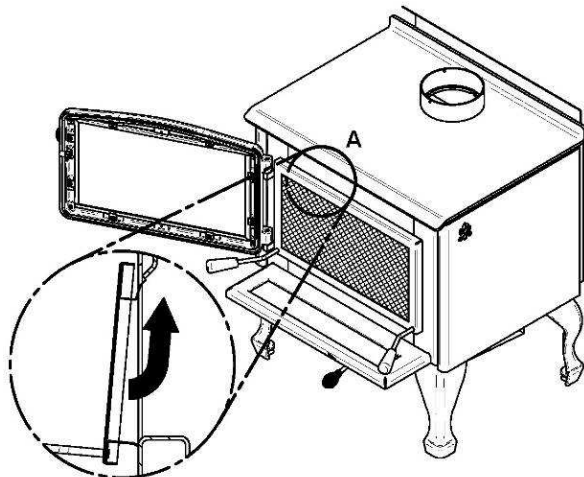

Lean the upper part of the fire screen against the top door opening making sure to insert the top fire screen brackets behind the primary air deflector as in (Detail A).

Lift the fire screen upwards and push the bottom part towards the stove then let the fire screen rest on the bottom of the door opening.

DETAIL A

**Warning:** Never leave the stove unattended while in use with the fire screen.

## APPENDIX 6: INSTALLATION AND USE OF THE BLOWER, AND USE OF THE OPTIONAL THERMODISC

Your Osburn 2000 comes with a blower. The blower assembly is the same for the version on pedestal and for the version on legs. All you need to do is secure the blower to the back of the stove using 4 screws (screws #10 x 1/2" type "a" pan quadrex black, supplied with the owner's manual).

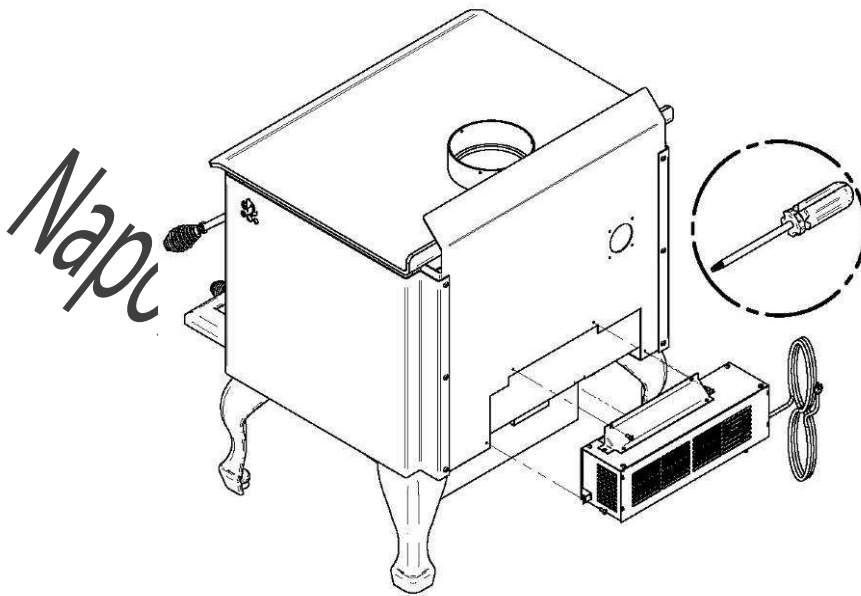

The blower is installed on the back of the stove to increase the flow of air past heat exchange surfaces and to help circulate warm air in the room. When used regularly, the blower can provide a small increase in efficiency, up to 2 percent. However, the use of a blower should not be used as a way to gain more output from a stove that is undersized for the space it is intended to heat.

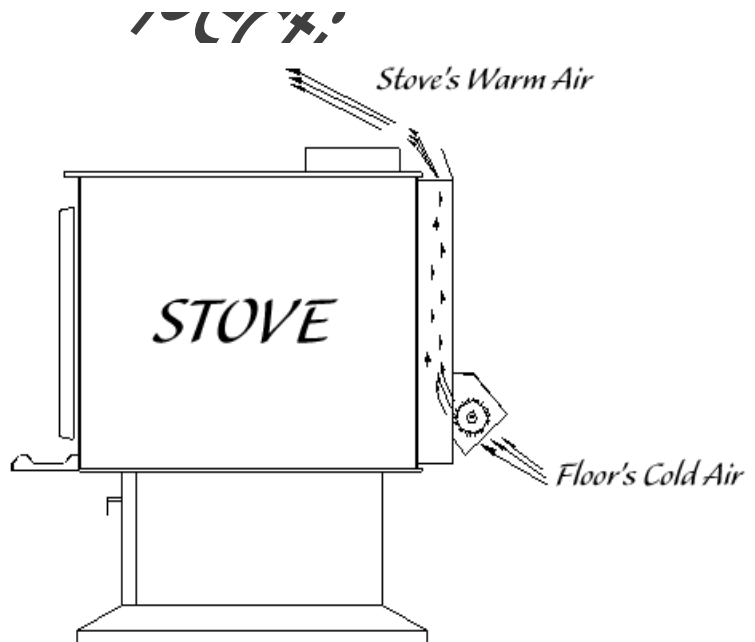

When using the optional blower, allow the stove to reach operating temperature (approximately one hour), before turning it on. The increased airflow from the blower cools the firebox and could affect the start-up combustion efficiency if the blower is turned on too early. You can also install a thermodisc to enable the blower to start or stop automatically when the stove is hot or too cold. The thermodisc part number is AC05530 for a basic model and ACO2055 for a quick connect model. Installation instructions are supplied with the blower and the thermodisc.

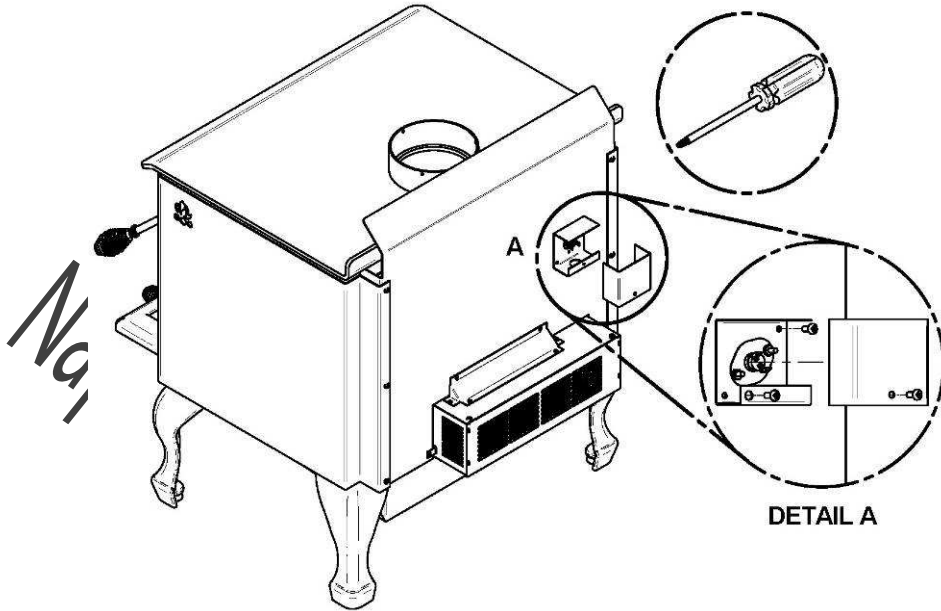

**CAUTION: ENSURE THAT THE BLOWER'S POWER CORD IS NOT IN CONTACT WITH ANY SURFACE OF THE STOVE TO PREVENT ELECTRICAL SHOCK OR FIRE DAMAGE. DO NOT RUN THE POWER CORD BENEATH THE STOVE.**



## APPENDIX 7: INSTALLATION OF SECONDARY AIR TUBES AND BAFFLE

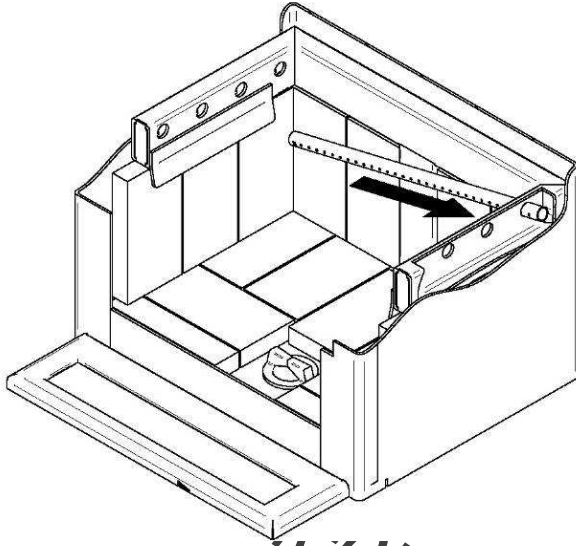

- 1- Starting with the rear tube, lean and insert the right end of the secondary air tube into the rear right channel hole. Then lift and insert the left end of the tube into the rear left channel.

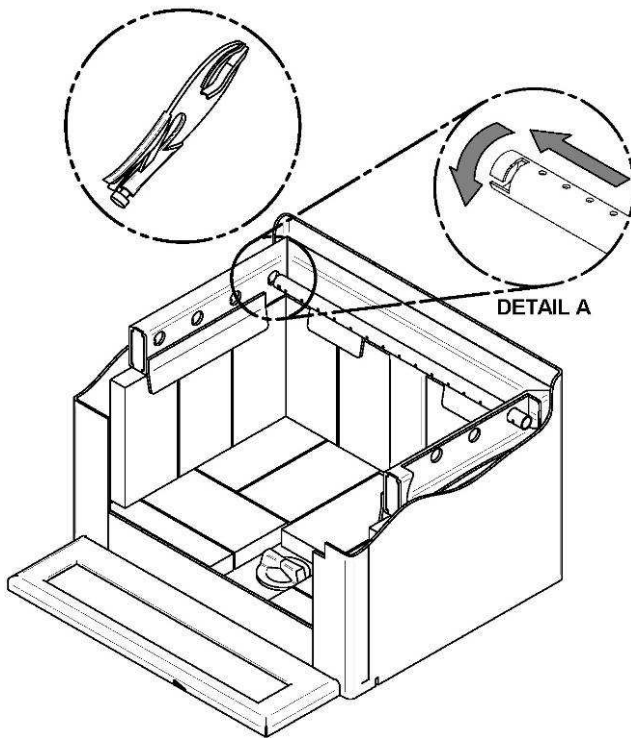

- 2- Align the notch in the left end of the tube with the key of the left air channel hole. Using a « Wise grip » hold the tube and lock it in place by turning the tube as shown in detail A. Make sure the notch reaches the end of the key way.
- 3- Repeat step 1 and 2 for the other secondary air tubes.
- 4- To remove the tubes use the above steps in reverse order.

Secondary air tubes (B) can be replaced without removing the baffle board (A).

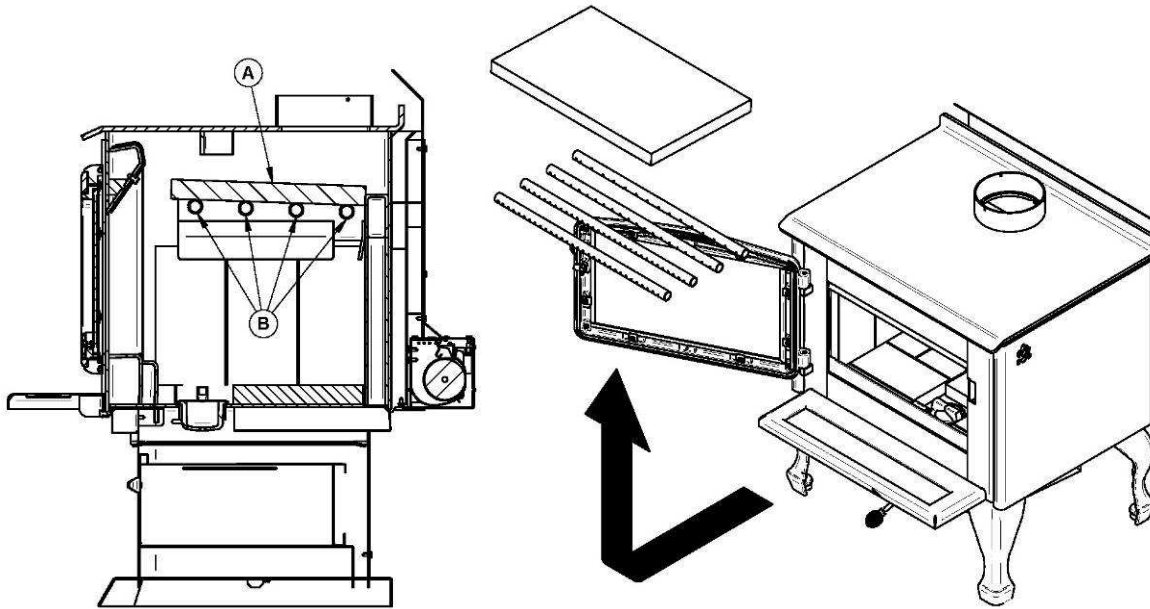

**Important Notes:**

The air tubes are identified for placement as follows:

| Model       | Type of tube   |
|-------------|--|
| Osburn 2000 | Front ▶ 30 holes of 0.147"<br>Middle front ▶ 30 holes of 0.136"<br>Middle rear ▶ 20 holes of 0.128"<br>Rear ▶ 15 holes of 0.128" |

## APPENDIX 8: EXPLODED DIAGRAM AND PARTS LIST

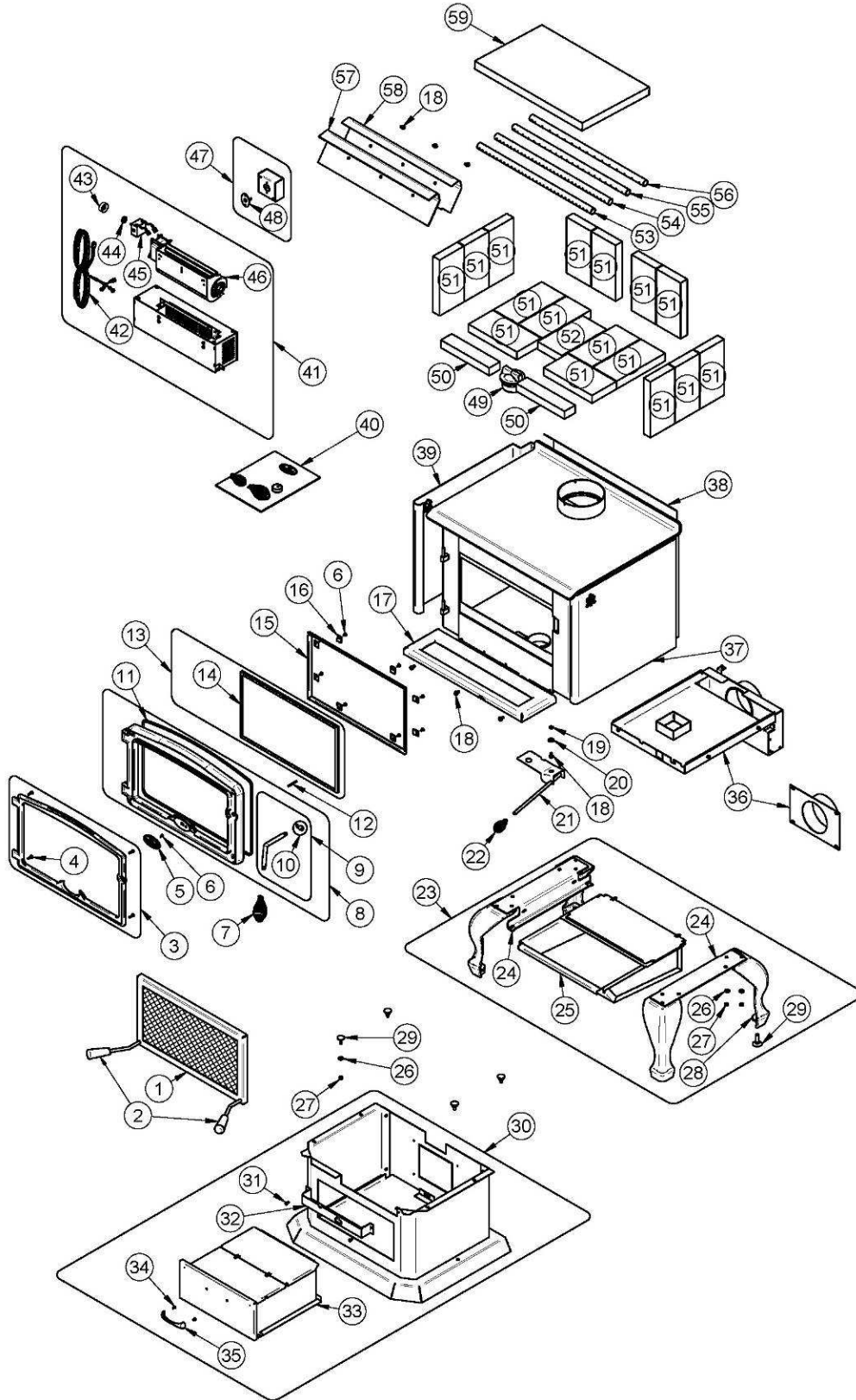

**IMPORTANT:** THIS IS DATED INFORMATION. When requesting service or replacement parts for your stove, please provide the model number and the serial number. We reserve the right to change parts due to technology upgrade or availability. Contact an authorized dealer to obtain any of these parts. Never use substitute materials. Use of non-approved parts can result in poor performance and safety hazards.

| #  | Item    | Description  | Qty |
|----|---------|--|-----|
| 1  | AC01315 | FIRE SCREEN  | 1   |
| 2  | 30569   | ROUND WOODEN HANDLE BLACK  | 1   |
| 3  | OA10221 | BROWN CAST IRON DOOR OVERLAY   | 1   |
| 3  | OA10222 | GOLD PLATED CAST IRON DOOR OVERLAY                                   | 1   |
| 3  | OA10220 | BLACK CAST IRON DOOR OVERLAY   | 1   |
| 3  | OA10224 | BRUSHED NICKEL CAST IRON DOOR OVERLAY                                | 1   |
| 4  | 30123   | SCREW #8 - 32 X 5/8" PAN QUADREX ZINC                                | 4   |
| 5  | 30450   | OSBURN DOOR LOGO   | 1   |
| 6  | 30124   | SCREW #8 - 32 X 5/16" TRUSS QUADREX ZINC                             | 9   |
| 7  | AC07868 | 1/2" BLACK COIL HANDLE   | 1   |
| 8  | SE24124 | CAST IRON DOOR WITH HANDLE AND GASKET                                | 1   |
| 9  | AC07900 | DOOR HANDLE AND LATCH KIT  | 1   |
| 10 | AC09185 | DOOR LATCH KIT   | 1   |
| 11 | AC06100 | BLACK GASKET AND SILICONE KIT 1/4" X 1/2" X 6'                       | 1   |
| 12 | 30101   | SPRING TENSION PIN 5/32" DIA X 1 1/2" L                              | 1   |
| 13 | SE53597 | REPLACEMENT GLASS WITH GASKET 10 9/16" X 18"                         | 1   |
| 14 | AC06400 | BLACK SELF-ADHESIVE GLASS GASKET KIT (6')                            | 1   |
| 15 | PL53588 | GLASS RETAINER FRAME   | 2   |
| 16 | PL53585 | GLASS RETAINER 3/4" X 7/8"   | 8   |
| 17 | PL65554 | ASH LIP  | 1   |
| 18 | 30060   | THREAD-CUTTING SCREW 1/4-20 X 1/2" F HEX STEEL SLOT WASHER C102 ZINC | 7   |
| 19 | 30187   | ZINC WASHER ID 17/64" X OD 1/2"                                      | 1   |
| 20 | 30206   | ZINC WASHER ID=5/16" X OD=3/4"                                       | 1   |
| 21 | SE65521 | AIR CONTROL ROD WITH DAMPER  | 1   |
| 22 | AC07869 | 3/8" BLACK COIL HANDLE   | 1   |
| 23 | OA10226 | BLACK LEG KIT  | 1   |
| 24 | PL65546 | LEFT OR RIGHT LEG SUPPORT  | 2   |
| 25 | SE53541 | ASH DRAWER LEGS VERSION  | 1   |
| 26 | 30185   | 17/64" "AA" TYPE WASHER  | 12  |
| 27 | 30100   | BLACK HEX NUT 1/4 - 20   | 12  |
| 28 | 24218   | BLACK CAST IRON LEG WITH LEVELING BOLT                               | 4   |
| 29 | 30050   | LEVELING BOLT 3/8-16 X 1 1/2"  | 4   |
| 30 | OA10225 | PEDESTAL AND ASH DRAWER KIT  | 1   |
| 31 | 30131   | BLACK METAL SCREW #10 X 1/2" TYPE "A" PAN QUADREX                    | 2   |
| 32 | PL65541 | AIR CONTROL COVER  | 1   |

| #  | Item    | Description  | Qty |
|----|---------|--|-----|
| 33 | SE53537 | ASH DRAWER PEDESTAL VERSION                            | 1   |
| 34 | 30108   | MECHANICAL SCREW M4 X 8MM PAN PHILLIPS ZINC            | 2   |
| 35 | 28062   | BLACK DRAWER HANDLE 3 25/32"                           | 1   |
| 36 | AC01316 | FRESH AIR INTAKE KIT (LEGS VERSION)                    | 1   |
| 36 | AC01336 | FRESH AIR INTAKE KIT (PEDESTAL VERSION)                | 1   |
| 37 | PL53705 | RIGHT DECORATIVE PANEL                                 | 1   |
| 38 | 99999   | BUILD TO ORDER   | 1   |
| 39 | PL53706 | LEFT DECORATIVE PANEL                                  | 1   |
| 40 | SE45553 | OSBURN 2000 STOVE INSTRUCTION MANUEL KIT               | 1   |
| 41 | AC03095 | ULTRA-QUIET 130 CFM BLOWER WITH VARIABLE SPEED CONTROL | 1   |
| 42 | 60013   | POWER CORD 96" X 18-3                                  | 1   |
| 43 | 44085   | RHEOSTAT KNOB  | 1   |
| 44 | 44087   | RHEOSTAT NUT   | 1   |
| 45 | 44080   | RHEOSTAT WITH NUT                                      | 1   |
| 46 | 44070   | CROSSFLOW BLOWER 115V-60Hz-56W (B)                     | 1   |
| 47 | AC05530 | THERMODISC KIT   | 1   |
| 48 | 44046   | THERMODISC F110-20F                                    | 1   |
| 49 | 24096   | ROUND CAST IRON ASH PLUG                               | 1   |
| 50 | VP00014 | 2" X 7 3/4" X 1 1/4" REFRACTORY BRICK                  | 2   |
| 51 | 29020   | 4 1/2" X 9" X 1 1/4" REFRACTORY BRICK HD               | 16  |
| 52 | PL36028 | 4 1/2" X 8 1/8" X 1 1/4" REFRACTORY BRICK              | 1   |
| 53 | PL65514 | FRONT SECONDARY AIR TUBE                               | 1   |
| 54 | PL65515 | MIDDLE FRONT SECONDARY AIR TUBE                        | 1   |
| 55 | PL65516 | MIDDLE REAR SECONDARY AIR TUBE                         | 1   |
| 56 | PL65517 | REAR SECONDARY AIR TUBE                                | 1   |
| 57 | 21387   | TOP AIR DEFLECTOR INSULATION                           | 1   |
| 58 | PL65505 | TOP AIR DEFLECTOR PROTECTOR                            | 1   |
| 59 | 21389   | C-CAST BAFFLE 20" X 12 1/2" X 1 1/4"                   | 1   |

## OSBURN LIMITED LIFETIME WARRANTY

The warranty of the manufacturer extends only to the original retail purchaser and is not transferable. This warranty covers brand new products only, which have not been altered, modified nor repaired since shipment from factory. Proof of purchase (dated bill of sale), model name and serial number must be supplied when making any warranty claim to your OSBURN dealer.

**This warranty applies to normal residential use only. Damages caused by misuse, abuse, improper installation, lack of maintenance, over firing, negligence or accident during transportation, power failures, downdrafts, venting problems or underestimated heating area are not covered by this warranty. The recommended heated area for a given appliance is defined by the manufacturer as its capacity to maintain a minimum acceptable temperature in the designated area in case of a power failure.**

This warranty does not cover any scratch, corrosion, distortion, or discoloration. Any defect or damage caused by the use of unauthorized or other than original parts voids this warranty. An authorized qualified technician must perform the installation in accordance with the instructions supplied with this product and all local and national building codes. Any service call related to an improper installation is not covered by this warranty.

The manufacturer may require that defective products be returned or that digital pictures be provided to support the claim. Returned products are to be shipped prepaid to the manufacturer for investigation. Transportation fees to ship the product back to the purchaser will be paid by the manufacturer. Repair work covered by the warranty, executed at the purchaser's domicile by an authorized qualified technician requires the prior approval of the manufacturer. All parts and labour costs covered by this warranty are limited according to the table below.

The manufacturer, at its discretion, may decide to repair or replace any part or unit after inspection and investigation of the defect. The manufacturer may, at its discretion, fully discharge all obligations with respect to this warranty by refunding the wholesale price of any warranted but defective parts. The manufacturer shall, in no event, be responsible for any uncommon, indirect, consequential damages of any nature, which are in excess of the original purchase price of the product. A one-time replacement limit applies to all parts benefiting from lifetime coverage. This warranty applies to products purchased after June 1<sup>st</sup>, 2015.

| DESCRIPTION   | WARRANTY APPLICATION* |         |
|---|-----------------------|---------|
|   | PARTS                 | LABOUR  |
| Combustion chamber (welds only) and cast iron door frame.   | Lifetime              | 5 years |
| Ceramic glass (thermal breakage only**), plating (manufacturing defect**), and convector air-mate.  | Lifetime              | N/A     |
| Surrounds, heat shields, ash drawer, steel legs, pedestal, trims (aluminum extrusions), C-Cast baffle**, vermiculite baffle**, secondary air tubes**, removable stainless steel combustion chamber, deflectors, and supports. | 7 years               | N/A     |
| Handle assembly, glass retainers and air control mechanism.   | 5 years               | 3 years |
| Removable carbon steel combustion chamber components.   | 5 years               | N/A     |
| Standard and optional blower, heat sensors, switches, rheostat, wiring, and electronics.  | 2 years               | 1 year  |
| Paint (peeling**), gaskets, insulation, ceramic fiber blankets, firebricks, and other options.  | 1 year                | N/A     |
| All parts replaced under the warranty.  | 90 days               | N/A     |

**\*Subject to limitations above. \*\*Picture required.**

Labour cost and repair work to the account of the manufacturer are based on a predetermined rate schedule and must not exceed the wholesale price of the replacement part.

Shall your unit or a components be defective, contact immediately your **OSBURN** dealer. To accelerate processing of your warranty claim, make sure to have on hand the following information when calling:

- Your name, address and telephone number;
- Bill of sale and dealer's name;
- Installation configuration;
- Serial number and model name as indicated on the nameplate fixed to the back of your unit;
- Nature of the defect and any relevant information.

**Before shipping your unit or defective component to our plant, you must obtain an Authorization Number from your OSBURN dealer. Any merchandise shipped to our plant without authorization will be refused automatically and returned to sender.**