

IMPORTANT:
THESE INSTRUCTIONS ARE TO
REMAIN WITH THE HOMEOWNER.
PLEASE SAVE THESE INSTRUCTIONS.

**PACIFIC
ENERGY**

SAFETY NOTICE

If this fireplace is not properly installed, a house fire may result. For your safety, follow the installation instructions. Contact local building or fire officials about restrictions and installation inspection requirements in your area.

SERIAL #

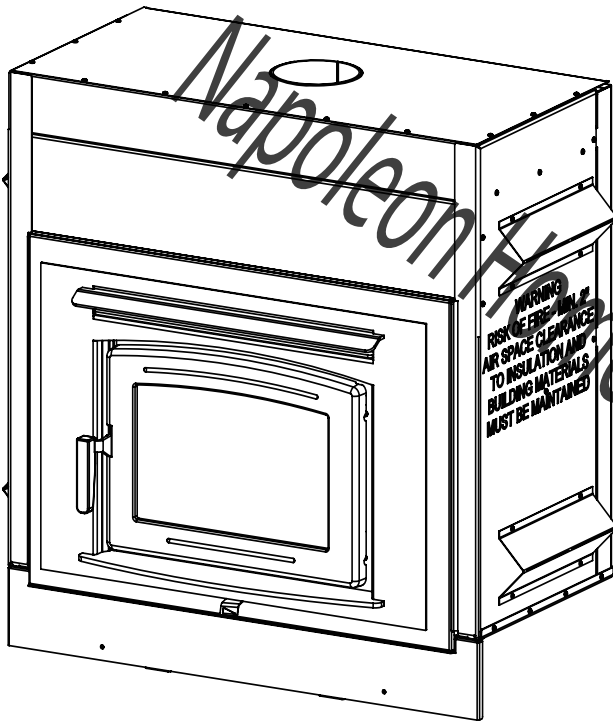

INSTALLATION AND OPERATING INSTRUCTIONS

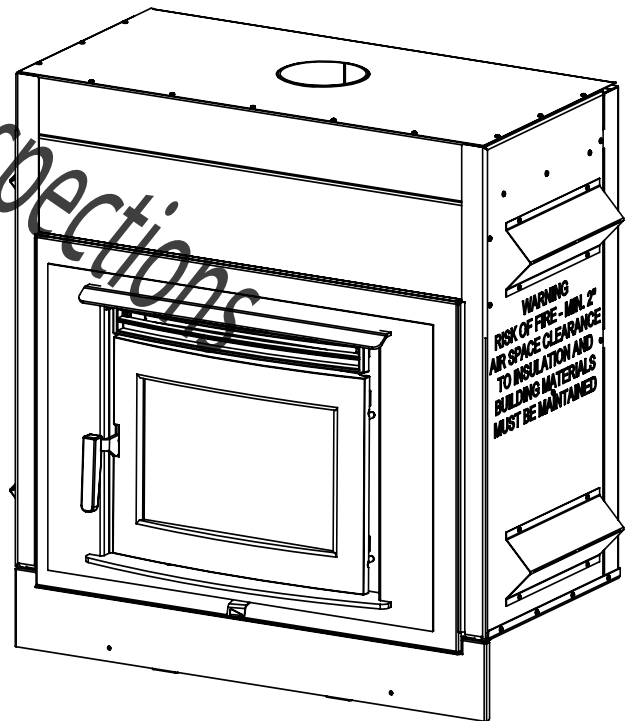

TESTED and LISTED to CAN/ULC
S610-M87 AND UL 127
Meets the Environmental Protection
Agency's May 2015 Particulate Emission
Standards



MODEL: FP16 & FP16AR

**ZERO CLEARANCE WOOD
FIREPLACE**

Contents

Safety and Maintenance	3
Maintenance Checks	4
Chimney Smoke and Creosote Formation.....	5
Chimney Fires.....	5
In the event of a Chimney Fire.....	5
Preventing a Chimney Fire.....	5
Wood Selection.....	5
How to Test Your Wood.....	5
Operation	6
Lighting a Fire.....	6
Normal Operation.....	6
Restarting After Extended or Overnight Burns.....	7
Overfiring.....	7
Heat Output Calculation.....	7
Proper Draft.....	7
Ash Removal.....	7
Disposal of Ashes.....	7
Blower Operation.....	7
Baffle Removal	8
Secondary Air Box Cleaning.....	8
Glass Cleaning.....	9
Blower Replacement.....	9
Firebrick Installation Instructions.....	10
Crate Removal.....	11
Locating The FP16 Fireplace.....	11
Clearances.....	11
Procedure.....	11
Fireplace Installation	11
Dimensions	12
Minimum Clearances to Combustibles	12
Minimum Framing Dimensions	13
Framing Kit Assembly	14
Chase/Enclosure.....	16
Listed Chimney and Chimney Connector.....	16
Offsets	17
Combustion Air	18
Framing	19
Ember Protection	20
Safety Strip.....	20
Blower Wiring.....	20
Mantel Clearances	21
Appendix A	22
Troubleshooting.....	22
Understanding & Operating Your Pacific Energy Fireplace.....	23
Replacement Parts.....	24
Warranty Information	25
Label Location.....	27
Label.....	27

PLEASE SAVE THESE INSTRUCTIONS

This manual describes the installation and operation of the Pacific Energy, FP16 wood heater. This heater meets the 2015 U.S. Environmental Protection Agency's crib wood emission limits for wood heaters sold after May 15, 2015. Under specific test conditions this heater has been shown to deliver heat at rates ranging from 10,800 to 24,600 Btu/hr.

NOTE: WE STRONGLY RECOMMEND THAT SMOKE AND CARBON MONOXIDE DETECTORS BE INSTALLED IN THE AREA WHERE THE HEATER IS TO BE INSTALLED.

If smoke detectors have been previously installed, you may notice that they are operating more frequently. This may be due to curing of stove paint or fumes caused by accidentally leaving the fire door open. Do not disconnect the detectors.

SAFETY NOTICE: If this stove is not properly installed, a house fire may result. For your safety, follow the installation instructions. Contact local building or fire officials about restrictions and installation inspection requirements in you area.

Please read this entire manual before you install and use your new room heater. Failure to follow instructions may result in property damage, bodily injury, or even death.

Safety and Maintenance

1. **Burn only, dry and well seasoned cord wood.** The denser or heavier the wood when dry, the greater its heat value. This is why hardwoods are generally preferred. Green or wet wood should not be used, it will reduce heat output, as well as, contribute significantly to creosote buildup.

WARNING: NEVER USE CHEMICALS OR ANY OTHER VOLATILE LIQUID TO START A FIRE. DO NOT BURN GARBAGE OR FLAMMABLE FLUIDS SUCH AS GASOLINE, NAPHTHA, OR ENGINE OIL. WE STRONGLY RECOMMEND THAT SMOKE DETECTORS BE INSTALLED.

2. Maintain a 1"(25mm) minimum ash base for best results. The area where boost combustion air enters the firebox must be kept clear of excessive ash buildup which will block air flow. This area is at the front of the firebox. Remove ashes if excess build occurs. Embers may roll out of the firebox door opening and create a fire hazard.
3. If glass becomes darkened through slow burning or poor wood, it can be cleaned with fireplace glass cleaner when the fireplace is cold. Never scrape with an object that might scratch the glass. The type and amount of deposit on the glass is a good indication of the flue pipe and chimney buildup. A light brown dusty deposit that is easily wiped off usually indicates good combustion and dry, well-seasoned wood and therefore relatively clean pipes and chimney. On the other hand, a black greasy deposit that is difficult to remove is a result of wet and green wood and too slow a burning rate. This heavy deposit is building up as quickly in the chimney.
4. Establish a routine for the fuel, wood burning and firing technique. Check daily for creosote buildup until experience shows how often you need to clean to be safe.

WARNING: ONLY USE MATERIALS AND COMPONENTS SUPPLIED OR SPECIFIED BY MANUFACTURER WHEN DOING MAINTENANCE OR REPLACEMENTS. DO NOT USE A FIREPLACE INSERT OR OTHER PRODUCTS NOT SPECIFIED FOR USE WITH THIS FIREPLACE.

5. **DOOR GASKETS** - The gasket used by Pacific Energy (3/4"(19mm) round high density fibreglass rope) requires only light pressure to seal. This will prolong seal life. It is important that the door seal be maintained in good condition. Periodically inspect seals and replace if necessary with WODC.NEODGKIT.
6. **DOOR GLASS** - Replacement glass can be obtained from your dealer. Use 16-1/2"(419mm) x 10-1/2"(267mm) x 5 mm ceramic glass only.

WARNING: DO NOT SUBSTITUTE GLASS WITH ANY OTHER TYPE MATERIAL OTHER THAN CERAMIC GLASS

WARNING: DO NOT SLAM LOADING DOOR OR OTHERWISE IMPACT GLASS. WHEN CLOSING DOOR, MAKE SURE THAT NO LOGS PROTRUDE TO IMPACT THE GLASS. IF THE GLASS GETS CRACKED OR BROKEN, IT MUST BE REPLACED BEFORE USING THE FIREPLACE.

WARNING: OVER FIRING THE APPLIANCE WILL SHORTEN THE LIFE OF THE PRODUCT. FAILURE TO RECTIFY AN OVER FIRING CONDITION CAN BE HAZARDOUS AND MAY VOID THE MANUFACTURER'S WARRANTY.

To remove broken glass, remove the door gasket and clean out the screw heads. Remove the screws that hold the retainer and remove the retainer, noting position for re-assembly. Remove all particles of glass. Be careful as they are very sharp. Install new glass complete with gasket. Replace retainer, screws and gasket.

CAUTION:

- DO NOT OVERTIGHTEN - TIGHTEN SCREWS HAND TIGHT
- DO NOT CLEAN GLASS WHEN HOT
- DO NOT USE ABRASIVE CLEANERS ON GLASS

7. Do not store wood within heater installation clearances, or within the space required for fuel loading and ash removal. Keep the area around the heater clean and free of loose combustibles, furniture, newspapers, etc.
8. Be aware that the hotter the fire, the less creosote is deposited. Weekly cleaning may be necessary in mild weather, even though monthly cleaning is usually enough in the coldest months when burning rates are higher.
9. Instruct all members of your family on the safe operation of the heater. Ensure they have enough knowledge of the entire system if they are expected to operate it. Stress the section on chimney fires and the importance of following the steps outlined "In Case of Chimney Fire".
10. Inspect and clean your chimney system at the beginning of the burning season before your first fire and at least every two months during the burning season. Inspect the interior and exterior of the pipe for defects and/or damage. Remove and inspect the rain cap. Refer to the chimney system manufacturer's installation instructions for the procedure to remove and or replace any necessary components to the chimney system.
11. Maintain a distance of 48"(1.22m) to all combustible materials in the room unless otherwise specified. (see Floor Protector section on page 19 for Floor Protection dimensions)

Maintenance Checks

Check the following parts for damage such as cracks, excessive corrosion, burned out sections and excessive warping:
(See website for descriptions and more detail)

Weekly:

- Firebrick - Visual, for cracking.
- Door Gasket - sagging, displacement, damage.

Monthly

- Brick rail tabs and brick rails.
- Air riser tube in the back of the firebox.
- Back side of airwash chamber.
- Baffle locking pin.
- Boost tube cover.

When Cleaning the Chimney System:

- Top baffle board/blanket.
- Baffle.
- Top heat shield and mounting bolt.
- Baffle Gasket.
- Brick Rails.
- Manifold.

Blowers:

- The blowers should be cleaned out annually or more often if required by using a vacuum on the intakes on the side of the blower to remove any dust and debris. The blower is accessed by removing both the outer and inner surrounds.

Baffle:

- Some warping of the baffle is normal (up to 1/4" or .65cm).
- Replace if the baffle has permanent warping greater than this or has cracking or breakage.
- Please contact your Dealer if you experience any of the damage listed above. Continuing to operate your fireplace with broken parts may accelerate damage to other parts and may void your warranty.

Chimney Smoke and Creosote Formation

When wood is burned slowly, it produces tar and other organic vapours, which combine with expelled moisture to form creosote. The creosote vapours condense in the relatively cool chimney flue of a slow burning fire. As a result, creosote residue accumulates on the flue lining. When ignited, this creosote makes an extremely hot fire. The chimney connector and chimney should be inspected periodically (at least once every two months) during the heating season to determine if a creosote buildup has occurred. If creosote has accumulated (3 mm. or more), it should be removed to reduce the risk of a chimney fire.

1. The highest smoke densities and emissions occur when a large amount of wood is added to a bed of hot coals and the air inlet is closed. The heated wood generates smoke, but without ample air, the smoke cannot burn. Smoke-free, clean burning requires smaller fuel loads, two or three logs at a time or 1/4 to 1/2 of fuel load and leaving the air inlet relatively wide open, especially during the first 10 to 30 minutes after each loading, when most of the smoke generating reactions are occurring. After 30 minutes or so, the air inlet can be turned down substantially without excessive smoke generation. Wood coals create very little creosote-producing smoke.
2. The cooler the surface over which the wood smoke is passing, the more creosote will be condensed. Wet or green wood contributes significantly to creosote formation as the excess moisture that is boiled off cools the fire, making it difficult for the tars and gases to ignite, thus creating dense smoke and poor combustion. This moisture-laden smoke cools the chimney, compounding the problem by offering the smoke the ideal place to condense.
In summary, a certain amount of creosote is inevitable and must be lived with. Regular inspection and cleaning is the solution. The use of dry, seasoned wood and ample combustion air will help to minimize annoying smoke emissions and creosote buildup.

Chimney Fires

The result of excessive creosote buildup is a chimney fire. Chimney fires are dangerous. Temperatures inside the chimney can exceed 2000° F (1093°C). This causes much higher than normal temperatures on its exterior surfaces. Thus ignition of nearby or touching combustible material is more likely during a chimney fire. Proper clearances are critical during such a fire.

Chimney fires are easy to detect; they usually involve one or more of the following:

- Flames and sparks shooting out of the top of the chimney
- A roaring sound
- Vibration of the chimney

In the event of a Chimney Fire

1. Prepare to evacuate to ensure everyone's safety. Have a well understood plan of action for evacuation. Have a place outside where everyone is to meet.
2. Close air inlet on fireplace.
3. Call local fire department. Have a fire extinguisher handy. Contact your local municipal or provincial fire authority for further information on how to handle a chimney fire. It is most important that you have a clearly understood plan on how to handle a chimney fire.
4. After the chimney fire is out, the chimney system must be cleaned and checked for damage before starting another fire. **Have the system inspected by a certified installer or chimney sweep.** Also check combustibles around the chimney and the roof.

Preventing a Chimney Fire

There are three things you can do to prevent chimney fires:

1. Do not let creosote build up to a point where a chimney fire is possible.
2. Do not have fires in the heater that may ignite chimney fires. These are very hot fires, such as when burning household trash, cardboard, Christmas tree limbs, or even ordinary fuel wood; (e.g.. with a full load on a hot bed of coals and with the air control open for long period of time.)
3. Regular inspections and cleaning.

The services of a competent or certified installer, (certified by the Wood Energy Technical Training program (WETT) - in Canada, Hearth Education Foundation (HEARTH) - in U.S.A.,) are strongly recommended.

Wood Selection

This heater is designed to burn natural wood only. Higher efficiency and lower emissions generally result when burning air-dried seasoned hardwoods, as compared to softwoods or to green or freshly cut hardwoods.

Wood should be properly air dried (seasoned) for six months or more. Wet or undried wood will cause the fire to smoulder and produce large amounts of creosote. Wet wood also produces very little heat and tends to go out often.

Do not burn anything but wood. Other fuels, eg. charcoal, can produce large amounts of carbon monoxide, a tasteless, odourless gas that can kill. Under no circumstances should you attempt to barbecue in this heater.

How to Test Your Wood

Add a large piece of wood to the fireplace when it has a large hot bed of coals. It is dry if it is burning on more than one side within one minute. It is damp if it turns black and lights within three minutes. If it sizzles, hisses and blackens without igniting in five minutes it is soaked and should not be burnt.

Operation

CAUTION: HOT WHILE IN OPERATION. KEEP CHILDREN, CLOTHING AND FURNITURE AWAY. CONTACT WILL CAUSE SKIN BURNS.

WARNING: OVER FIRING THE APPLIANCE WILL SHORTEN THE LIFE OF THE PRODUCT. FAILURE TO RECTIFY AN OVER FIRING CONDITION CAN BE HAZARDOUS AND MAY VOID THE MANUFACTURER'S WARRANTY.

DO NOT OVER FIRE THIS HEATER: ATTEMPTS TO ACHIEVE HEAT OUTPUT RATES THAT EXCEED HEATER DESIGN SPECIFICATIONS CAN RESULT IN PERMANENT DAMAGE TO THE HEATER AND CHIMNEY AND MAY VOID MANUFACTURERS WARRANTY.

CAUTION: Never use gasoline, gasoline type lantern fuel, kerosene, charcoal lighter fluid or similar liquids to start or "freshen up" a fire in this heater. Keep all such liquids well away from the heater while it is in use.

DO NOT BURN :

- Salt water wood*
- Wet or green wood
- Garbage*
- Lawn clippings/yard waste
- Railroad ties
- Materials containing rubber, including tires
- Materials containing plastic
- Waste petroleum products, paints or paint thinners, or asphalt products
- Materials containing asbestos
- Construction or demolition debris
- Paper products, cardboard, plywood, or particleboard.
- Treated wood
- Coal/charcoal
- Solvents
- Unseasoned wood
- Manure or animal remains

* **These materials contain chlorides which will rapidly destroy metal surfaces and void warranty.**

Burning these materials may result in the release of toxic fumes or render the heater ineffective and cause smoke.

The prohibition against burning these materials does not prohibit the use of fire starters made from paper, cardboard, saw dust, wax and similar substances for the purpose of starting a fire in an affected wood heater.

Your PACIFIC ENERGY heater is designed for maximum overall efficiency at a moderate firing rate. Over firing is hazardous and a waste of fuel. Too slow a burn contributes to creosote buildup and lowers combustion efficiency.

NOTE: Left and Right as referred to in this manual are considered your left and right when facing the front of the fireplace.

Lighting a Fire

WARNING: Never use chemicals or any other volatile liquid to start a fire.

1. Adjust air control to "High" position (all the way to the left) and open door.
2. Place crumpled newspaper in the centre of the heater and criss-cross with several pieces of dry kindling. Add a few small pieces of dry wood on top.

3. Ignite the paper and leave the door ajar approximately 1/2"(13mm) - 1"(25mm) until the wood kindling is fully engulfed in flame.
4. After the kindling is fully engulfed add a few small logs. Close door.
5. Begin normal operation after a good coal base exists and wood has charred.

Curing of the Paint Finish

When burning your stove for the first 2-3 times it is very important that the room be well ventilated. Open all windows and doors. Smoke and fumes caused by the curing process may cause discomfort to some individuals.

Normal Operation

WARNING: This wood heater has a manufacturer-set minimum low burn rate that must not be altered. It is against federal regulations to alter this setting or otherwise operate this wood heater in a manner inconsistent with the operating instructions in this manual.

1. Set air control to a desired setting. If smoke pours down across the glass (waterfall effect) this indicates you have shut the control down too soon or you are using too low a setting. The wide range control makes finding the desired setting for your application easy. As every home's heating needs vary (ie. insulation, windows, climate, etc.) the proper setting can only be found by trial and error and should be noted for future burns.
2. To refuel, adjust air control to "High" position (all the way to the left), and give the fire time to brighten. Open the door slowly, this will prevent backpuffing or flame roll-out.
3. Use wood of different shape, diameter and length (recommended 16"(406mm)). Load your wood and try to place the logs so that the air can flow between them. Always use dry wood.
4. Do not load fuel to a height or in such a manner that would be hazardous when opening the door.
5. For extended or overnight burns, unsplit logs are preferred. Remember to charge the wood completely on "High" setting before adjusting air control to the "Low" setting for overnight burn.

WARNING: Always keep the loading door closed when burning. This heater is not designed for open door burning. If unit is operated with the door open, gases and flame may be drawn out of the fireplace opening creating risks of both fire and smoke.

WARNING: No alteration or modification of the combustion air control assembly is permitted. Any tampering will void warranty and could be very hazardous.

WARNING: Do not use grates or andirons to elevate the fuel. Burn directly on the fire bricks. Replace broken or missing bricks. Failure to do so may create a hazardous condition.

Restarting After Extended or Overnight Burns

1. Open door and rake any hot embers towards the front of the heater. Add a couple of dry, split logs on top of the embers, close the door.
2. Adjust the air control to the "High" position (all the way to the left) and in just a few minutes, logs should begin burning.
3. After the wood has charred, reset the air control to the desired setting.
4. To achieve the maximum firing rate, set the air control to high. Do not use this setting other than for starting or preheating fresh fuel loads.

Overfiring

Over firing can be caused by the following; operating the unit with the door open, damage to door gaskets allowing excess air to enter the firebox, the use of kiln dried lumber, mill ends or paper waste and prolonged or continual use on a high burn setting.

Heat Output Calculation

Seasoned wood has approximately 7500 BTU's per pound.

The calculation is as follows:

$\frac{\text{Amount of wood in lbs. X 7500BTU's}}{\text{Burn rate in Hrs.}} \times .8(80\% \text{ Avg. Efficiency})$
--

Experience will give you the right settings for proper combustion and efficient burning. Remember the correct air inlet setting is affected by variables such as type of wood, outside temperature, chimney size and weather conditions. With practice, you will become proficient in operating your heater and will obtain the performance for which it was designed.

Proper Draft

- Draft is the force which moves air from the appliance up through the chimney. The amount of draft in your chimney depends on the length of the chimney, local geography, nearby obstructions and other factors.
- Too much draft may cause excessive temperatures in the appliance. An uncontrollable burn or a glowing red fireplace part or chimney indicates excessive draft.
- Inadequate draft may cause back puffing into the room and plugging of the chimney. Smoke leaking into the room through appliance and chimney connector joints indicates inadequate draft.

Ash Removal

Caution: Ashes are to be removed only when the heater is cold. Whenever ashes get 3(76mm) to 4(102mm) inches deep in your firebox, remove excess ashes. Leave an ash bed approximately 1" (25 mm) deep on the firebox bottom to help maintain a hot charcoal bed.

Disposal of Ashes

Ashes should be placed in a metal container with a tight fitting lid. The closed container of ashes should be placed outside on a non-combustible floor or on the ground, well away from all combustible materials, pending final disposal. If the ashes are disposed of by burial in soil or otherwise locally dispersed, they should be retained in closed container until all cinders have thoroughly cooled. Other waste should not be placed in this container.

Blower Operation

The blowers are wired with a thermo switch that will turn on the blower automatically once the fireplace has reached an appropriate operating temperature.

The blowers must be wired to a wall switch or fan speed controller for manual control(not included). If a blower should ever need to be replaced, power to the blowers can be shut off at the switch during replacement.

Baffle Removal

DO NOT OPERATE WITH BAFFLE ASSEMBLY OR INSULATION REMOVED.

WARNING: AFTER YOU REMOVE THE BAFFLE, ALWAYS COVER THE TOP OF THE BAFFLE AIR TUBE LOCATED IN THE REAR OF THE FIREBOX. THIS PREVENTS DEBRIS FALLING DOWN THE TUBE. FAILURE TO DO SO WILL RESULT IN POOR OPERATION AND POSSIBLE DAMAGE TO FIREPLACE COMPONENTS.

Remove retaining pin located just beneath the baffle at the rear inside top of the firebox. Remove either of the Side Brick Rails by lifting up on the baffle and dis-engaging the rail from its mounting posts. Lift baffle up and pull forward to disconnect from the supply tube. Slide the baffle to one side and then tilt baffle sideways to drop down and remove from firebox. To re-install the baffle, perform the removal steps in the reverse order. Ensure that the two side pieces of insulation are set tight against the baffle. If the insulation is damaged during removal, it should be replaced.

Secondary Air Box Cleaning

1. The secondary air box access is located on the bottom rear of the fireplace and can be accessed for cleaning by removing the two bottom center bricks inside the fireplace Fig. #1. This will expose the access cover.
2. Remove the screws securing the access cover to the firebox bottom. Inspect airbox for debris. If debris is present, carefully use a vacuum to suck debris through the hole in the firebox bottom.
3. Replace the cover plate and the bricks.

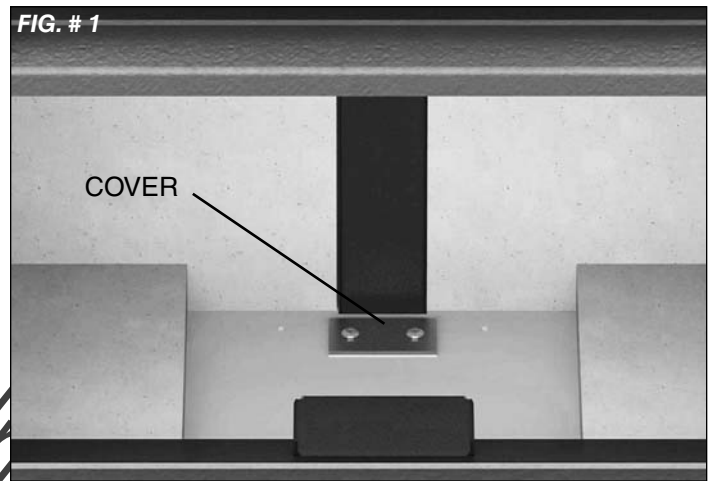
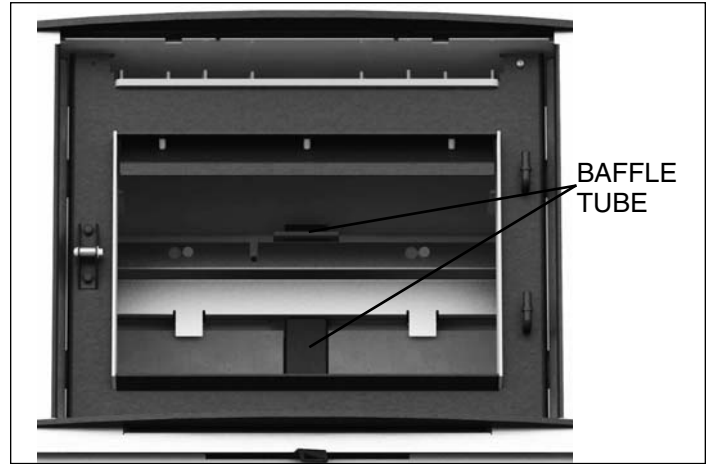

Glass Cleaning

If glass becomes darkened due to poor burning conditions, it can be cleaned with fireplace/ceramic glass cleaner when the fireplace is cold. Never scrape with an object that might scratch the glass. The type and amount of deposit on the glass is a good indication of flue pipe and chimney buildup. A light brown dusty deposit that is easily wiped off usually indicates good combustion and dry, well-seasoned wood and therefore relatively clean pipes and chimney. On the other hand, a black greasy deposit that is difficult to remove is a result of green wood or poor draft. NOTE: This heavy deposit is building up just as quickly in the chimney.

Blower Replacement

1. Remove the surround front by lifting and pulling away from the unit. Remove the four screws securing the back surround to the brackets and set the surround aside carefully to avoid damage.

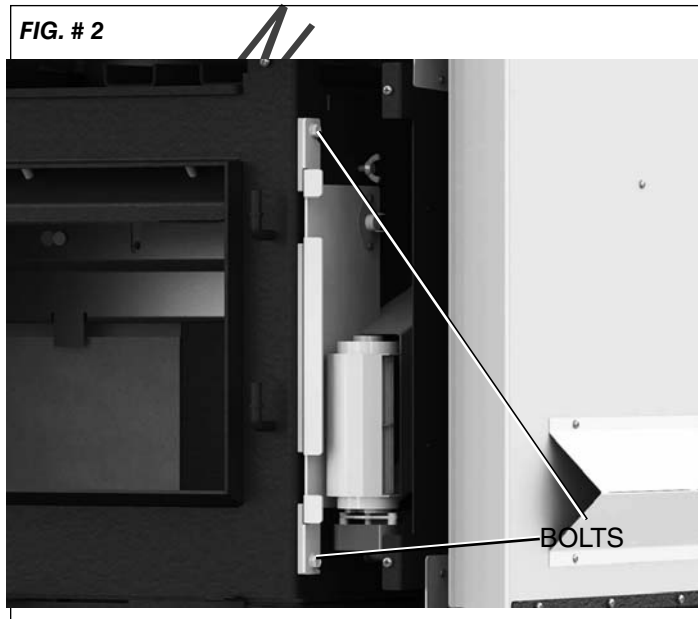

2. With a 3/8" (10mm) wrench, loosen the two bolts securing the blower mounting bracket to the unit. Fig. #2
3. Disconnect the two wires leading to the blower motor.
4. Pull the blower mounting bracket bottom out first and then lift the blower up and back to remove from the bolts. If replacing the right side blower, then disconnect the two wires leading to the thermo-switch at this time as well.
5. Remove the three screws securing the blower to the mounting bracket and replace the blower. Fig. #3
6. Reverse all previous steps to reinstall the new blower.

FIG. # 3

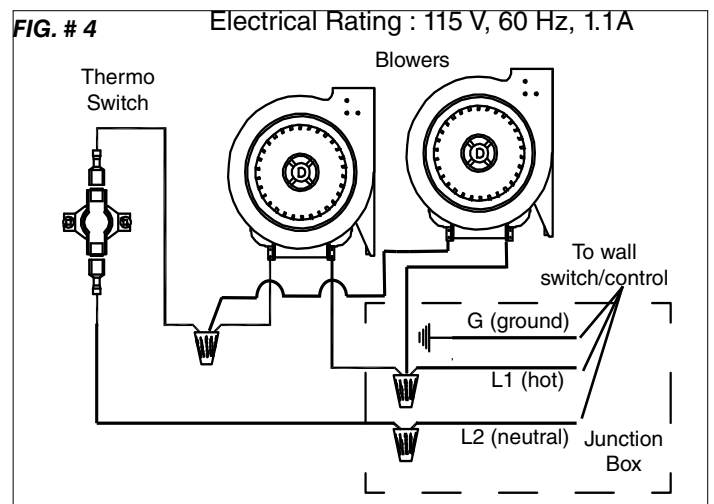
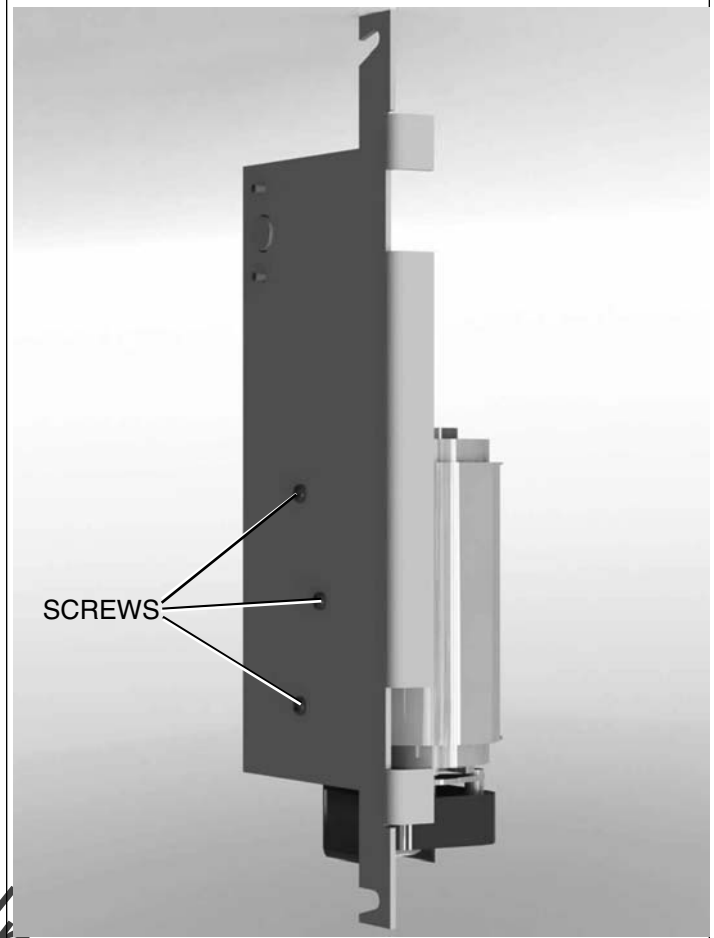

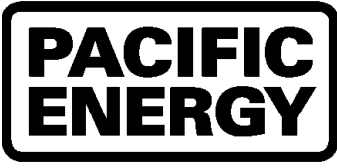

Firebrick Installation Instructions

FP16

This package contains 14 full-size firebricks.

With the heater in the upright position, install firebricks as follows:

- First, install 4 firebricks against the rear wall.
- Next, install the side firebricks, 3 each side.
- Lastly, place 4 firebricks on the bottom of the heater.

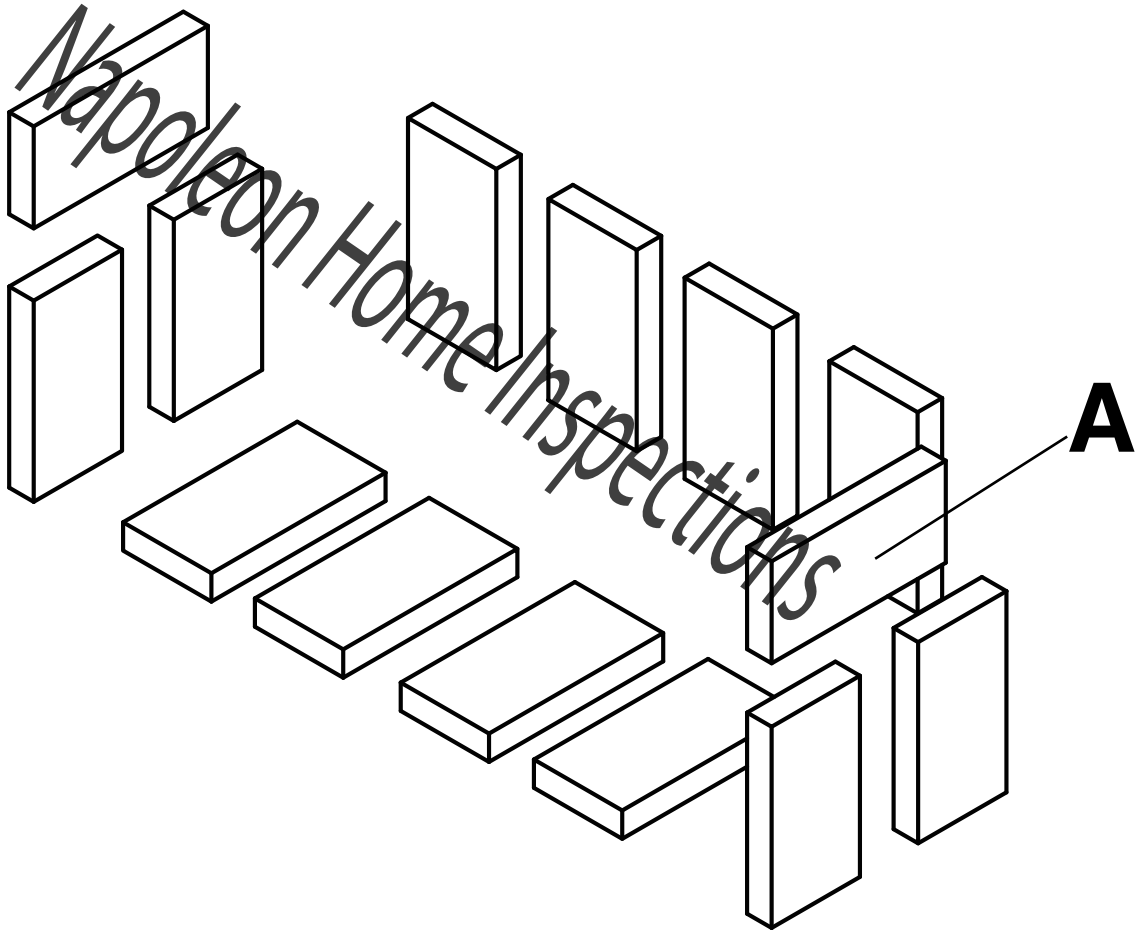

ITEM	SIZE	PART NUMBER
A	9" X 4 1/2" X 1 1/4" (230 mm x 115 mm x 32 mm)	5096.99



Fireplace Installation

Crate Removal

- 1) Carefully remove wood top and supports.
- 2) Remove the screws securing the fireplace to the pallet(4).
- 3) Remove from pallet bottom.

Warning: Under no circumstances is this heater to be installed in a makeshift or "temporary" manner. It may be fired only after the following conditions have been met.

- DO NOT CONNECT THIS UNIT TO A CHIMNEY FLUE SERVING ANOTHER APPLIANCE.

- WARNING:DO NOT INSTALL IN A SLEEPING ROOM. (MANUFACTURED OR MOBILE HOME ONLY)

- The services of a competent or certified installer, (certified by the Wood Energy Technical Training program (WETT) - in Canada, Hearth Education Foundation (HEARTH) - in U.S.A.,) are strongly recommended.

Locating The FP16 Fireplace

The best location to install your fireplace is determined by considering the location of windows, doors, and the traffic flow in the room where the FP16 Fireplace is located, allowing space in front of the unit for the hearth extension and the mantel, and taking into consideration the location of the chimney. Ideally, you should choose a location where the chimney will pass through the house without cutting floor or roof joists.

Check the adequacy of the floor by first estimating the weight of the fireplace system (approx. 500lbs(227Kg)). Next measure the area the fireplace will occupy. Note the floor construction and consult your local building code to determine if any additional support is needed. In most cases, no additional floor support is needed for the FP16 fireplace.

The FP16 fireplace may be installed directly on a combustible floor or on a raised base. A minimum of 72"(1.83m) measured from the base of the appliance to the ceiling is required.

The FP16 fireplace may not be installed in a factory built fireplace unless tested with the fireplace.

Wind direction and magnitude can play a factor in the chimney performance. Therefore the chimney outlet position is important when locating the fireplace

We recommend, whenever possible, that the chimney should:

- Penetrate the highest part of the roof.
- Be installed as far as possible from roof offsets, trees or any other obstructions that may cause wind turbulence or back drafts in the chimney.
- Contain the least number of offsets (elbows) possible.

Clearances

Clearances to combustible surfaces and materials are shown on pages 11 & 16.

Clearances may be reduced with various heat insulating materials. Consult local, National fire codes and authorities for approval.

Procedure:

Note: See "Combustion Air" section on page 17.

MAINTAIN CLEARANCES TO COMBUSTIBLES AS SPECIFIED IN THE INSTALLATION INSTRUCTIONS

CAUTION:THE STRUCTURAL INTEGRITY OF THE FLOOR, WALL AND CEILING/ROOF MUST BE MAINTAINED.

THE SPACE HEATER MUST BE CONNECTED TO A FACTORY-BUILT CHIMNEY CONFORMING TO CAN/ULC-S629 AND UL 103HT STANDARDS FOR 650C FACTORY-BUILT CHIMNEYS.

1. Position fireplace and floor protection in accordance with the clearances as stated on the label and in these installation instructions.
2. Mark the position for the hole for the chimney in the ceiling and roof by using a string and plumb-bob.
3. Check that the intended location will not interfere with floor joists, ceiling joists or rafters before proceeding further.

Dimensions

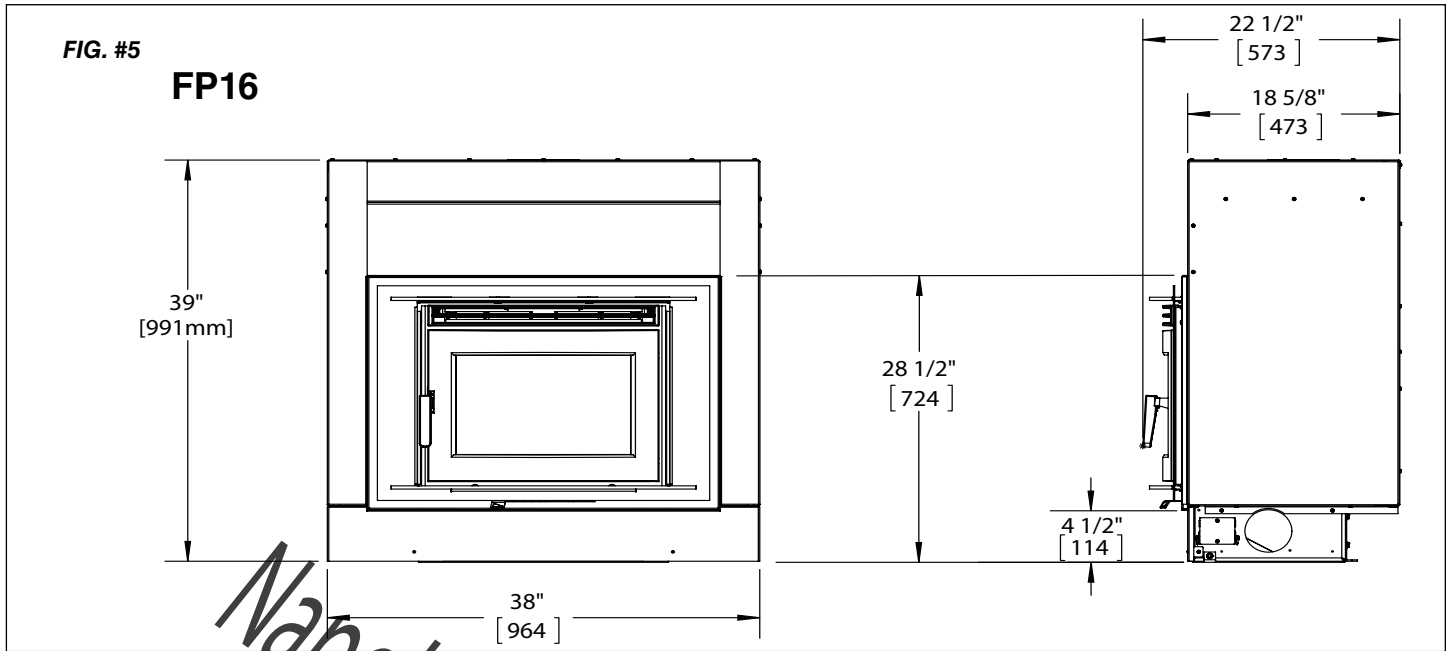

Minimum Clearances to Combustibles

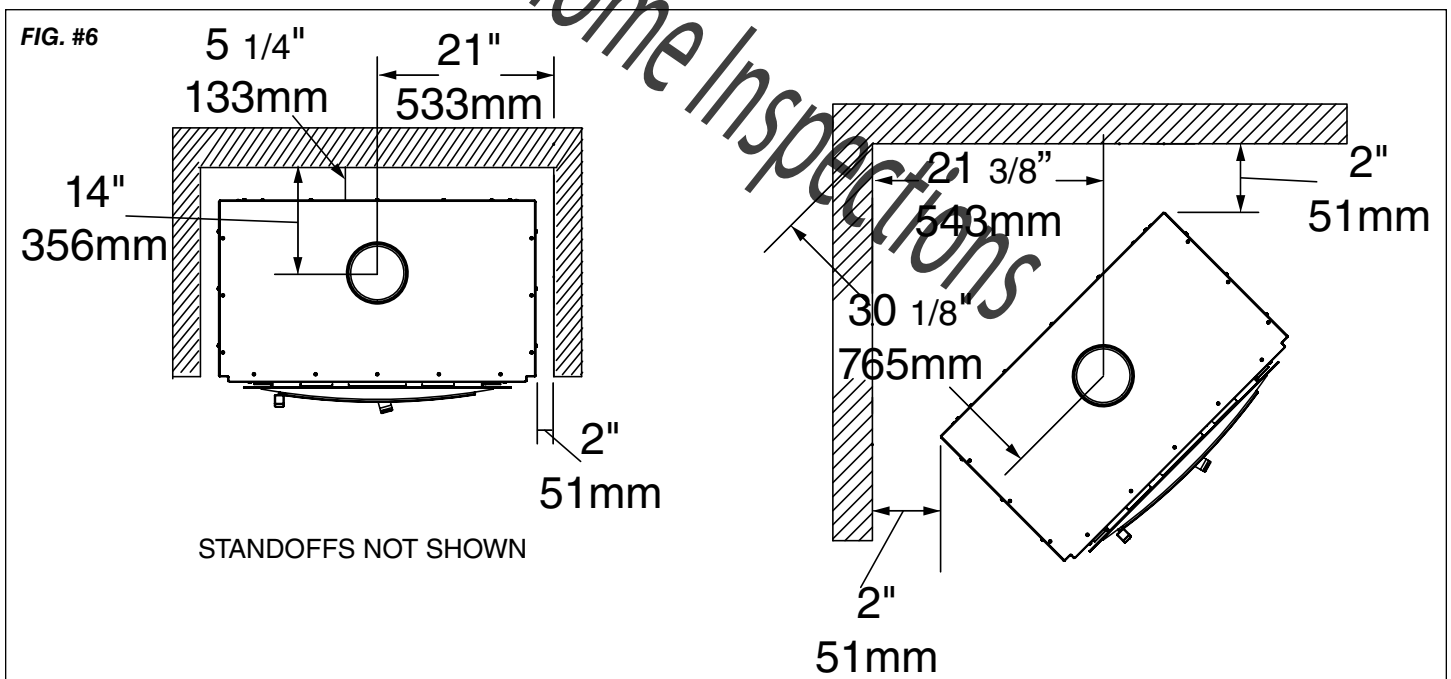

Minimum Framing Dimensions

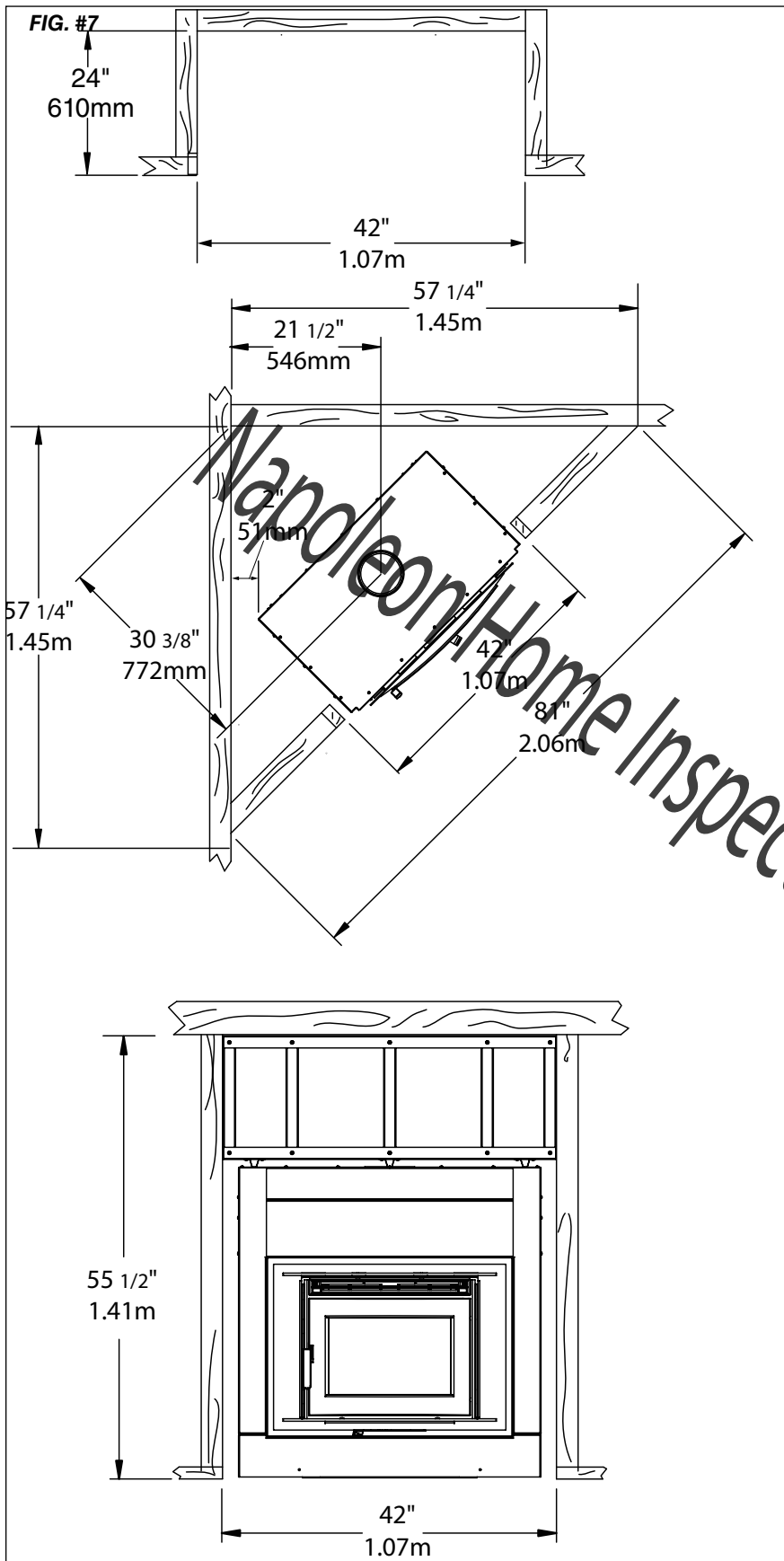

NOTE: FRAMING DIMENSIONS AROUND THE FIREPLACE ARE THE MINIMUMS. FRAMING DIMENSIONS WILL NEED TO BE ADJUSTED ACCORDINGLY TO ACCEPT DRYWALL IF USED INSIDE ENCLOSURE.

Napoleon Home Inspections

Framing Kit Assembly

Each Kit Contains:

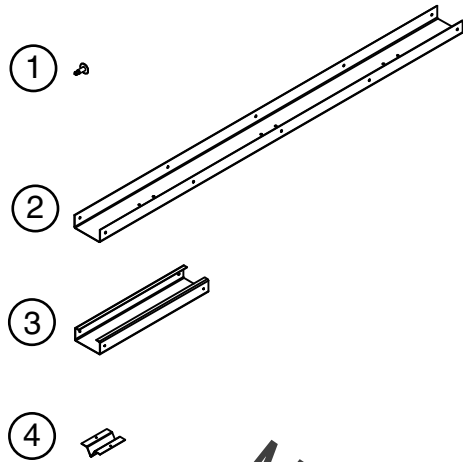

Item	Part #	Description	Qty.	
1	5049.9912	SCREW, TEKS #8 x 1/2"(13mm)	Pkg 40	
2	7946	STUD, TOP/BOTTOM 41 3/4"(1.06m)L	2	
3	7746.5	STUD, CNTR SUPPORT SIDES, 15"(381mm)L	5	
4	7747	FRAMING KIT LEG 3 1/2"(89mm)L	3	

Assembly

- Lay out top/bottom studs (2) and center studs (3) on a large flat surface. (Fig #9)
- Using the screws provided (1), attach the framing kit legs(4) to the bottom stud (2).
- Next, attach each center support(3) to the bottom stud(2) and then attach the top stud(2) to the center supports(3).

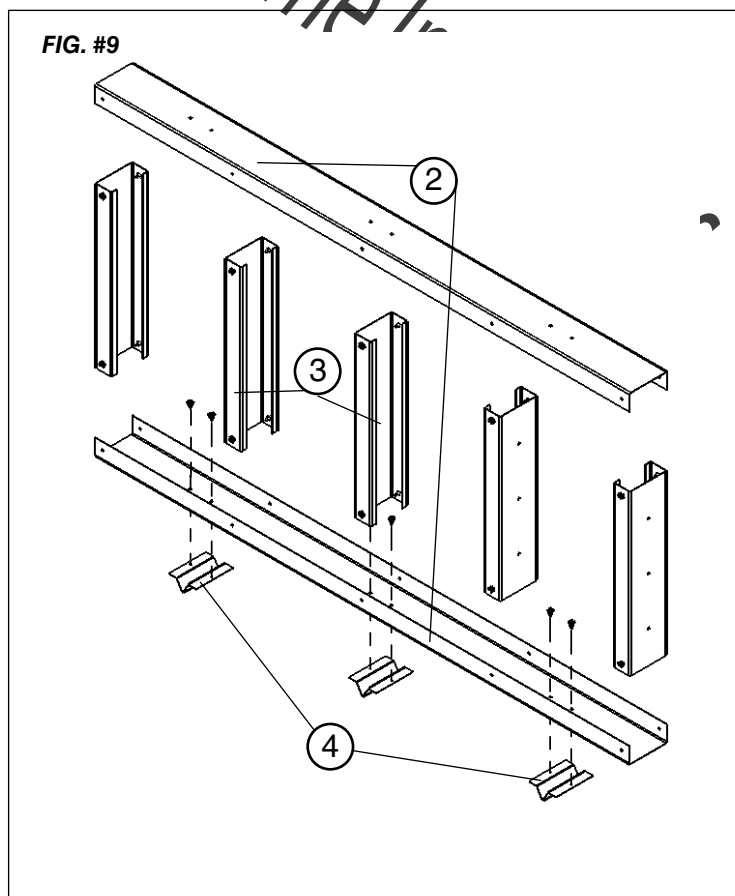
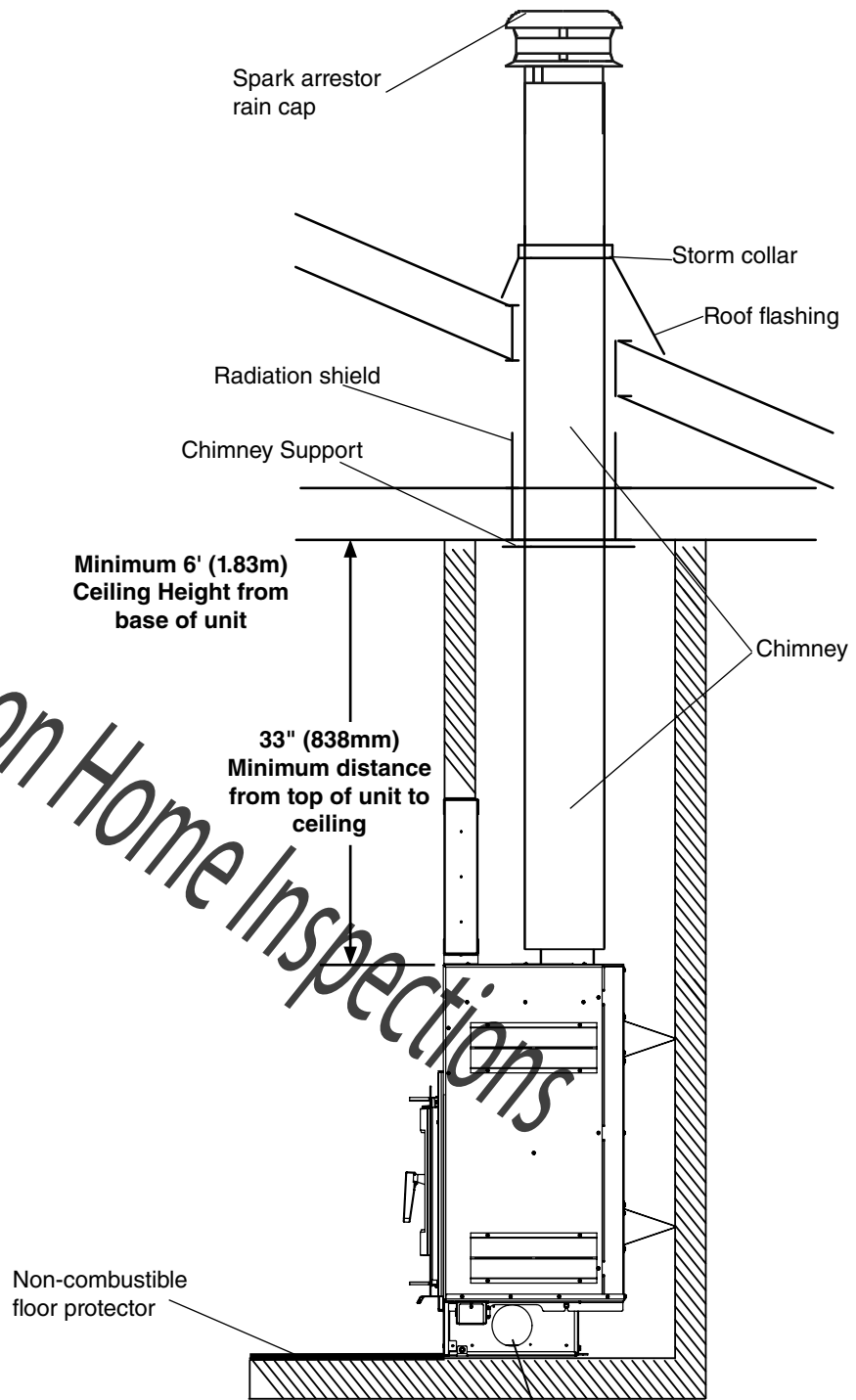

FIG. #8

The chimney may incorporate an offset. To do this safely, all sections of listed connector, offset elbows and chimney section must be screwed together by at least three sheet metal screws per joint. The chimney must be suitably supported by the chimney manufacturer's listed offset support. NOTE: Maximum unsupported chimney height is 20 feet(6.1m)



Napoleon Home Inspections

* 4"(102mm) diameter combustion outside air inlet. One on either side of unit. Also one in rear and on bottom of base plate if desired.

Chase/Enclosure

WARNING: Combustible materials cannot be used in the space directly above the fireplace. Do not fill the space above the fireplace with any material. (except the wood framing)

WARNING: The fireplace must not be in contact with any insulation or loose filling material. Cover the insulation with drywall panels around the fireplace.

WARNING: Drywall materials are considered combustible and their thickness must be accounted for in your framing dimensions.

If the chimney runs up the outside of the residence, we recommend it be enclosed in a chase structure. The chase should be constructed in such a way that it is an extension of the home. It should be well insulated between the footings and the floor of the home to prevent heat loss. We also recommend to insulate the ceiling of the chase just as if it were in the attic space. This will prevent cold air from dropping down through the chase and into the room where the fireplace is installed. Some local codes require that the walls be insulated, vapor sealed and sheathed with a fire rated gypsum board. We strongly recommend this procedure for all installations to prevent cold drafts from originating in the fireplace enclosure. If you follow this procedure, do not insulate the wall directly above the front of the fireplace.

NOTE: Check local codes concerning installation requirements and restrictions in your area.

Chimney Installation

Listed Chimney and Chimney Connector

This appliance must be installed with a 6"(150mm) chimney system approved under the following standards: CAN-ULC S629(IN CANADA) AND UL 103HT(IN U.S.).

YOU MUST FOLLOW THE CHIMNEY MANUFACTURER'S INSTALLATION INSTRUCTIONS FOR INSTALLATION OF ALL CHIMNEY COMPONENTS.

MAINTAIN CLEARANCES TO COMBUSTIBLES AS SPECIFIED IN THE CHIMNEY MANUFACTURERS INSTALLATION INSTRUCTIONS

USE APPROPRIATE SUPPORTS, CAPS, FLASHING AND SHIELDS IN ACCORDANCE WITH THE CHIMNEY MANUFACTURERS INSTALLATION INSTRUCTIONS.

THE FOLLOWING INSTRUCTIONS ARE GENERAL GUIDELINES ONLY.

CAUTION: THE STRUCTURAL INTEGRITY OF THE FLOOR, WALL AND CEILING/ROOF MUST BE MAINTAINED.

NOTE: FOR ALL CHIMNEYS, YOU MUST USE THE MANUFACTURER'S FIREPLACE ANCHOR PLATE.

NOTE: The FP16 must be installed so the outlet of the chimney system is a minimum 15ft(4.6m) in height as measured from the base of the unit.

NOTE: Longer chimney lengths and different pitch flashings may be used. All other parts indicated can be installed (see Figure 8, Page 14). Install all components to the chimney manufacturer's installation requirements. Consult your chimney supplier for installation advice.

1. After locating the desired location and framing in the fireplace, cut and frame square holes in all floors, ceilings, and roof that the chimney will pass through. Use a plumb bob to line up the holes. The chimney support is mounted to the framing.
2. Maintain a minimum 2"(51mm) clearance between the chimney and any combustible materials. Do not fill the space with insulation or any other combustible material.
3. Install the pipe manufacturer's, **fireplace anchor plate** by inserting it into the flue collar on the fireplace. We recommend sealing the joint with stove cement. Secure the anchor plate with stainless steel screws.
4. Assemble the chimney sections so the finished length is resting on the manufacturer's adapter and protruding through the roof. Avoid having joints between the ceiling and the roof. It is required that the chimney connections be secured with three (3)-#8 x 1/2"(12 mm) metal screws.
5. Install the radiation shields, firestops and all pieces necessary to prevent contact with combustible materials whenever passing through floors, ceilings or attic spaces.
6. Install the roof support then assemble the flashing and the storm collar. Be sure to maintain the vapour barrier at this point. (Seal securely.)
7. Attach the rain cap and check the flashing for leaks.
8. If the chimney extends more than 5'(1.5m) above the point of contact with the roof, then it must be secured using roof braces.

Offsets

The chimney for the FP16 can be installed with a maximum of four 45° elbows(in Canada) and four 30° elbows(in U.S.A.) as shown in Fig. #10.

Installation:

1. NOTE: Install the first elbow and turn it in the required direction.
2. Install the necessary chimney lengths to achieve the required offset. Lock the chimney lengths together according to the chimney manufacturer's instructions. If the offset length is made of two (2) chimney lengths or more, many chimney manufacturers may require that you use an offset or roof support halfway up the offset. If penetrating a wall, install a wall radiation shield supplied by the chimney manufacturer and install according to the manufacturer's instructions.
3. Use another elbow to turn the chimney vertically and secure the elbow.
4. Use a plumb bob to line up the centre of the hole with the center of the flue collar on the fireplace. Cut a hole for the chimney in the ceiling/floor. Frame the hole as described on page 15.
5. Install a firestop following the chimney manufacturer's directions.
6. Follow the chimney manufacturer's guidelines for supporting the offsets. Reminder - The chimney must be supported after the first 20'(6.1m).

NOTE: IT IS REQUIRED THAT ALL CHIMNEY SYSTEM CONNECTIONS BE SECURED WITH (3)-#8 X ½"(12 MM) METAL SCREWS.

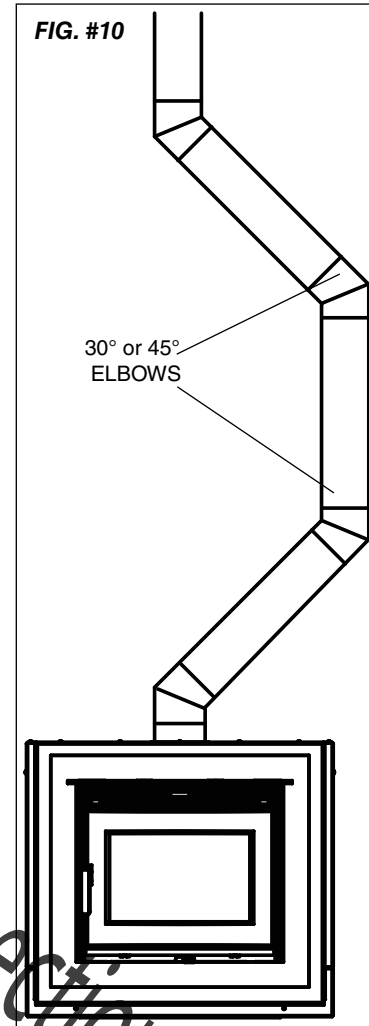

Table 1 Fireplace Clearances and Dimensions

A	Distance of combustible material from side, back standoffs and framing kit.	0" (0,0 mm)
B	Minimum distance of adjacent wall to side of fireplace door.	15" (381mm)
C	Ceiling clearance: from the base of the fireplace to the ceiling.	6' (1.83m)
D	Minimum chimney height: minimum total chimney height from fireplace bottom to below the chimney rain cap.	15' (4.6m)
E	Recommended maximum chimney height (at sea level) from top of fireplace to rain cap.	35' (10.7m)
F	Maximum unsupported chimney height.	20' (6.1m)
G	Minimum depth of non-combustible ember protector: from the front of the fireplace.	18" (457mm)
H	Minimum width of floor protection from side of door opening(in U.S.A.) and from side of unit(in Canada).	8" (203 mm)
I	Minimum distance to side facing from fireplace door opening.	12" (305mm)

Combustion Air

Intake or combustion air can be supplied to the fireplace in one of two ways. Consult your local building code or CAN/CSA-B365, Installation Code for Solid-Fuel-Burning Appliances and Equipment before proceeding.

1. **Outside air supply** - Outside air may be drawn through either side, the back or from below the unit using 4"(100mm) rigid or flex pipe into any of the openings provided in the support base. (Fig. #11).

Installation:

Use an approved 4"(100mm) inlet vent cap. Cut or drill a corresponding hole in the closest exterior wall or in the floor anywhere inside the chase. **Cover the hole with a 20GA wire mesh minimum, rodent screen and staple/nail in place.** Provide water protection as required. Attach 4"(100mm) venting (not supplied).

A typical outside air connection is shown in Fig. #12.

WARNING: This hole must get its air from the outdoors and be finished with an approved vent cap. The use of outside combustion air for residential installations requires that the fireplace be secured to the structure to prevent dislodging of the air duct. Check local building codes for instructions on sealing the vent cap at the penetration point of the building. The combustion air inlet ducts can not terminate in an attic space or garage.

2. **Room air supply** - The fireplace will draw its air from the room through the space behind the front trim plate and into the firebox intake. You must ensure the room has adequate air to operate the unit.

WARNING: This unit is not designed to be operated with the firing door open. In addition to the obvious hazard of sparks landing on combustibles, an open fire door will cause the heater to draw excess air from the living space and possibly cause suffocation.

CAUTION: The living space around the heater must be well ventilated with good air circulation. Anything that may cause a negative pressure can cause gases or fumes to be pulled into the living area. During extremely cold weather, and especially when burning at very slow rates, the upper parts of the exposed chimney may ice up, partially blocking the flue gases. If blockage occurs, flue gases may enter living space.

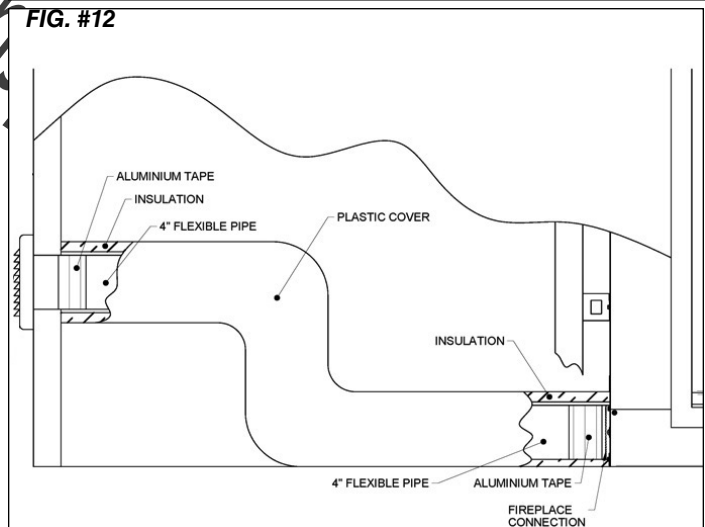
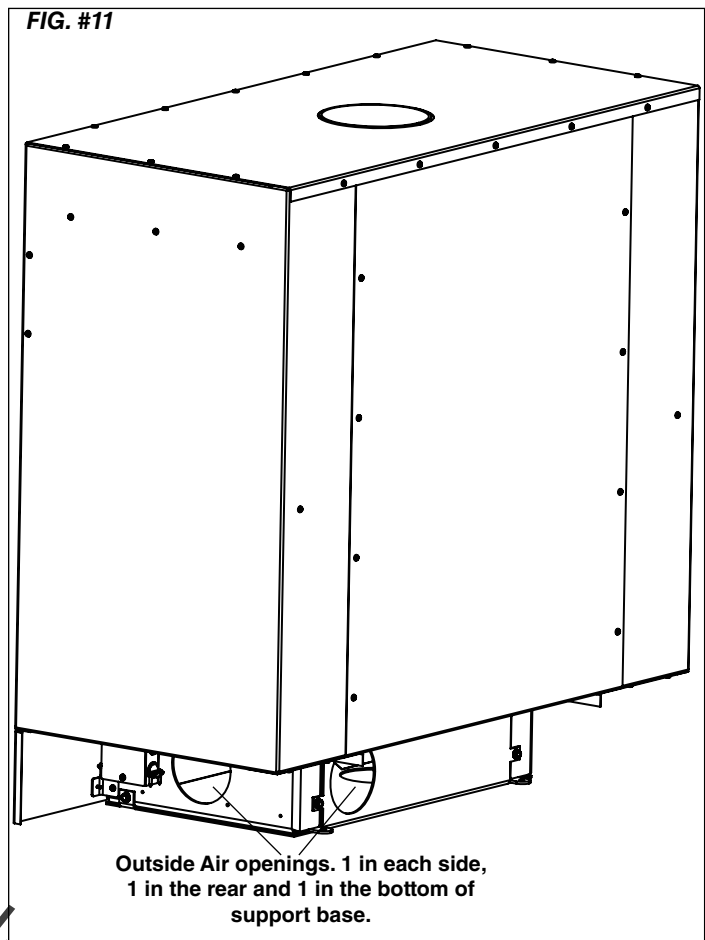

WARNING: THE COMBUSTION AIR INLET MUST BE AT LEAST 5ft(1.5m) BELOW CHIMNEY FLUE AND MUST NEVER TERMINATE IN ATTIC SPACES.

Framing

Typical Installation

The front facing area of the FP16 must be covered with non-combustible cement board prior to applying any non-combustible finishing material.

Frame the unit in as shown in Fig. #13 below using the framing kit provided on top of the unit, then 2x4 wood or metal framing above that.

The **wood** framing must be installed as shown below with no **wood** framing directly in front of the chimney.

The cement board must cover from the floor to the ceiling and the full width of the unit(42"(1.07m)).

Use the manufactures suggested fasteners to attach the cement board and install as recommended.

Finish the joints as per the board manufacturers recommendations.

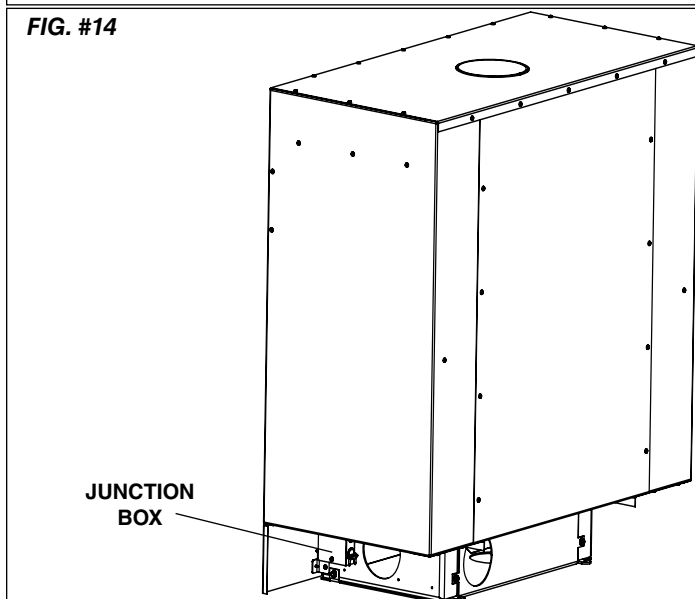
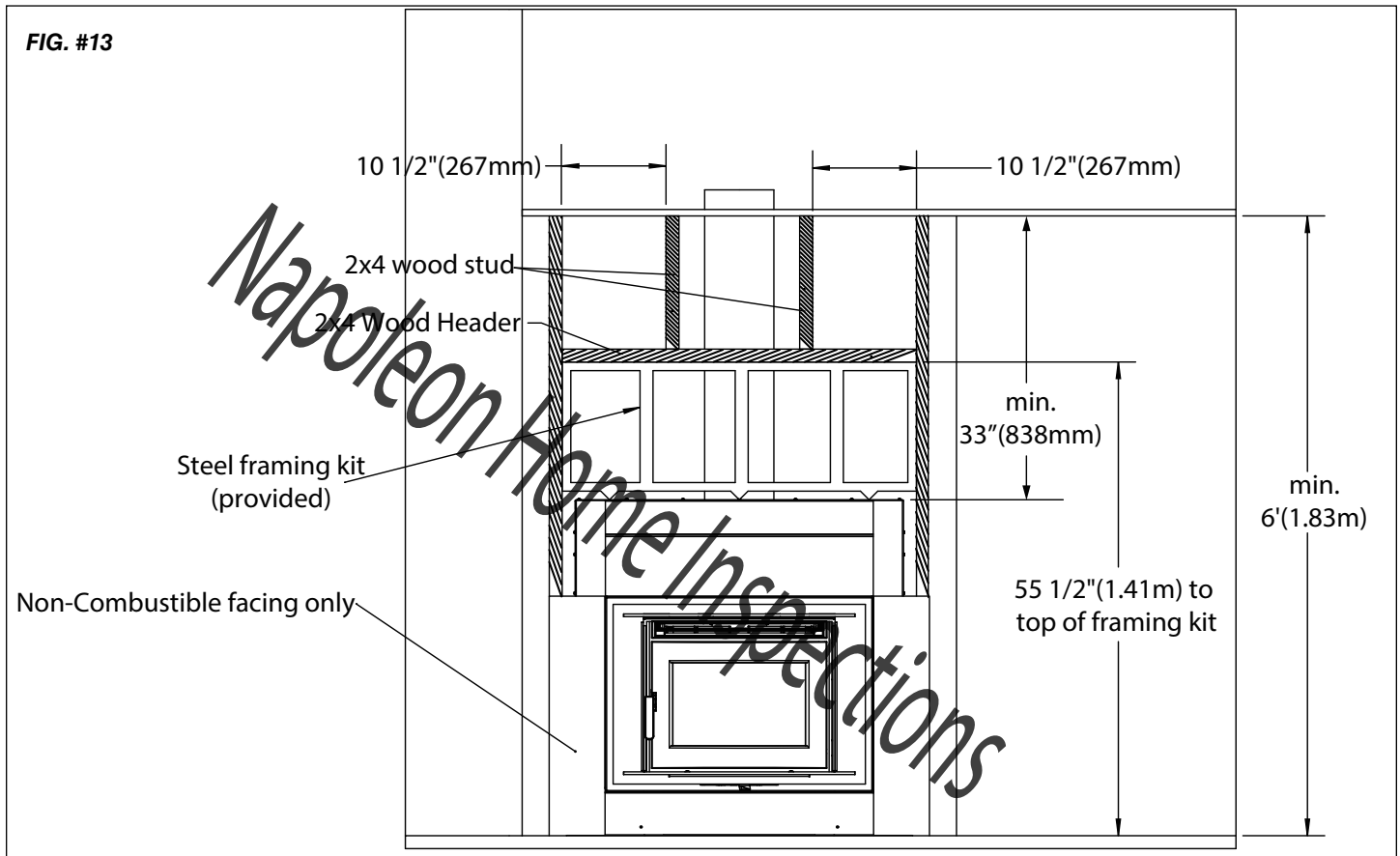

Ember Protection

The stove may be installed on a combustible floor provided ember protection made from a non-combustible material with a minimum K value of 23.7 btu/ft h °F is used. Equivalent to 20GA steel.

This protection must extend as follows:

In Canada: 18" (457 mm) on the firing side and 8"(203mm) to the sides. See Figure #15, below.

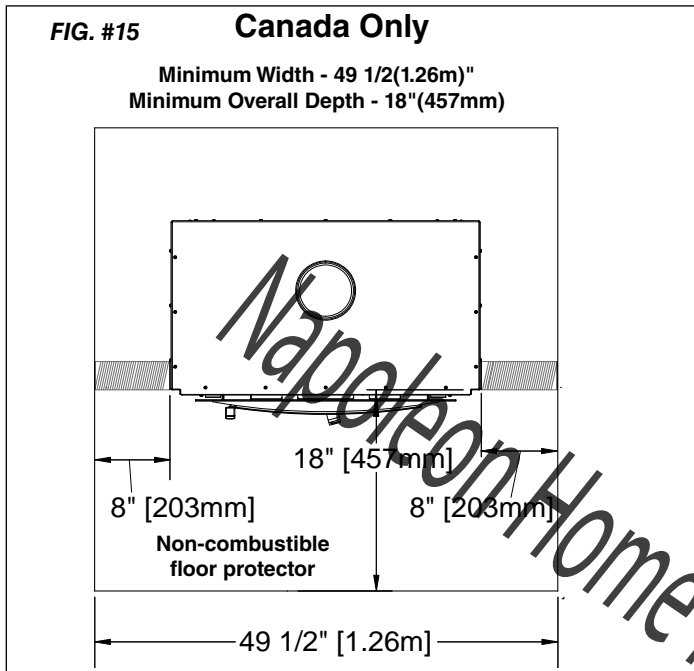

In U.S.A: 18" (457 mm) to the front and 8"(203mm) to the sides of the fuel loading door opening. See Figure #16, below.

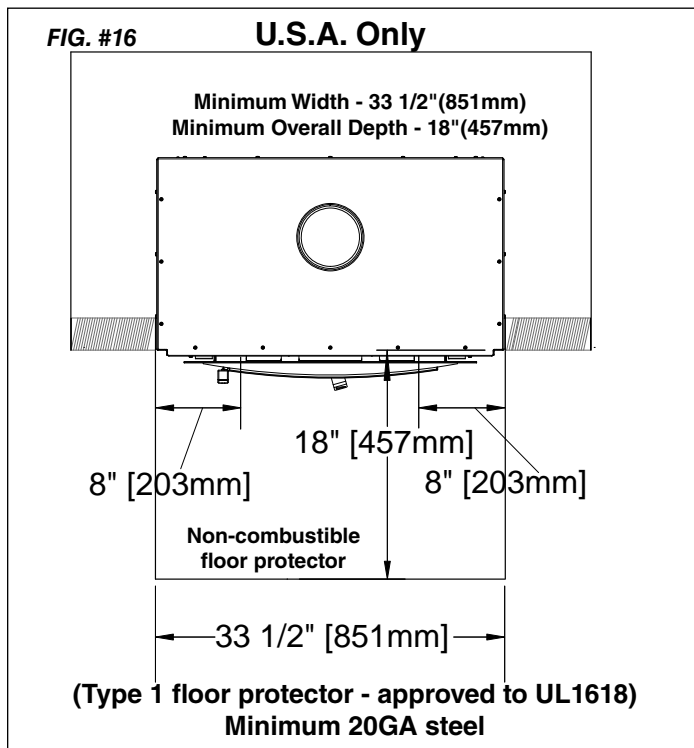

Safety Strip

The floor between the fireplace and the hearth extension/ember protection must be protected with a 2"(51mm) deep safety metal strip equal to the width of the unit.

One half of the metal strip must be under the fireplace front and the other half must extend onto the floor and under the hearth extension/ember protection as shown in Fig. #17.

FIG. #17

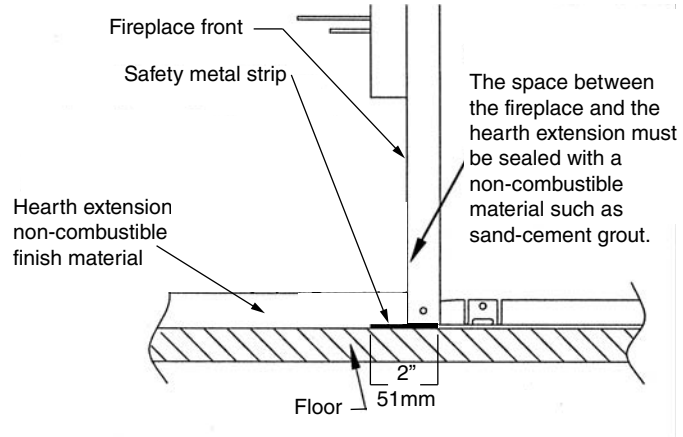

Blower Wiring

The FP16 blowers must be connected to 120 VAC house hold electrical system.

It is recommended to also connect the circuit to a wall switch or fan speed controller.(not supplied)

Insert the Romex 14/2 wire, or equivalent, into the unit through the strain relief located in the junction box on the right hand side of the support base Fig. #14, page18.

Connect the wiring as shown in the wiring diagram below to the wires located in the junction box. See section (Blower Replacement) on Page 8. All electrical connections should be performed by a certified/licensed electrician.

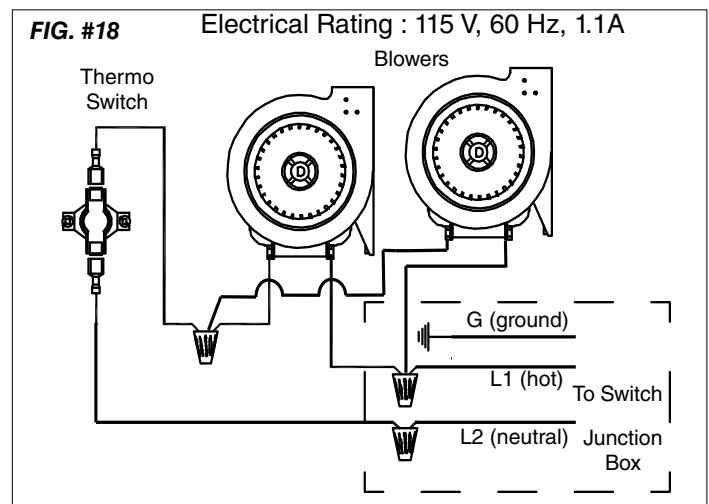

Mantel Clearances

FIG. #19

Graduated Mantle	
Depth (A)	Height from floor (B)
4"(102mm)	46 1/2"(1.18m)
5"(127mm)	47"(1.19m)
6"(150mm)	47 1/2"(1.21m)
7"(178mm)	48"(1.22m)
8"(203mm)	48 1/2"(1.23m)
9"(229mm)	49"(1.25m)
10"(254mm)	49 1/2"(1.26m)
11"(279mm)	50"(1.27m)
12"(305mm)	50 1/2"(1.28m)

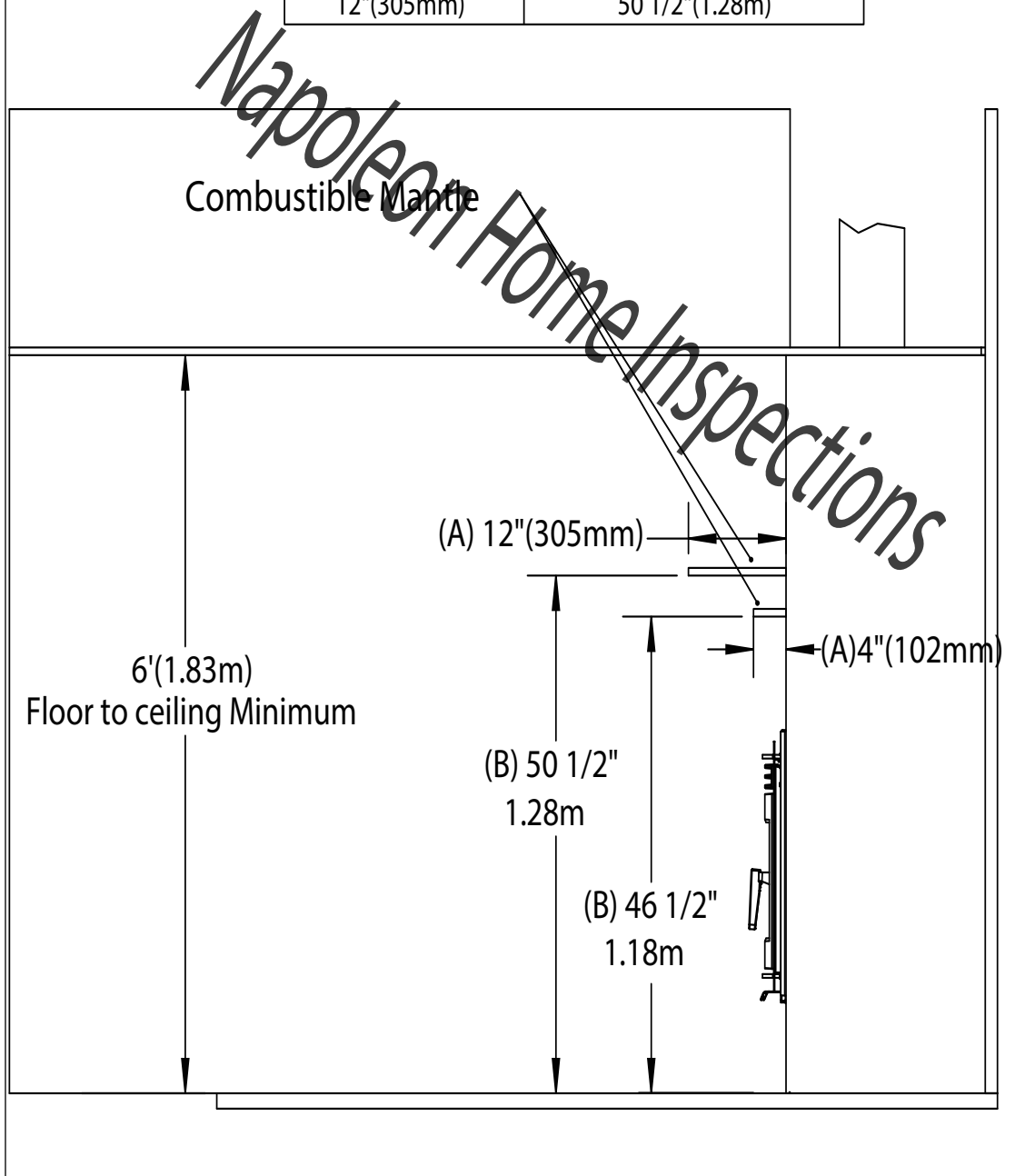

Appendix A

Troubleshooting

Problem	Cause	Cure
Glass is Dirty	1. Wood is wet	- Ensure wood is dried to less than 20% moisture content
	2. Turning down air control or damper too soon	- Do not turn air control down until: a) there is a good bed of coals built up b) the wood is charred
	3. Draft too low	- Chimney plugged or restricted, inspect and clean - Improper chimney design, height and/or diameter - Provide outside air for combustion
	4. Door gasket leakage	- Replace gasket - Check latch
	5. Baffle not installed correctly	- check to see that the baffle is properly installed over the air tube and locking pin is installed
Excessive Creosote Buildup	See 1, 2, 3, above.	
Low Heat Output	1. Wood is wet	- Ensure wood is dried to less than 20% moisture content
	2. Fire too small for room size	- Build a larger fire
	3. Draft too low to achieve larger fire	- Chimney plugged or restricted, inspect and clean
Won't Burn Overnight	1. Air control is set too high	- Reduce air control setting
	2. Not enough wood for the burn rate selected	- Unsplit wood is preferred for overnight burns
	3. Draft too high	- Excessive chimney height and/or diameter
Fireplace Won't Burn	1. Combustion air supply blocked	- Check outside air supply for obstruction - Check that room air cover is removed
	2. Draft too low	- Chimney plugged or restricted, inspect and clean - Chimney oversized or otherwise unsuitable, consult Dealer
	3. Baffle not installed correctly	- check to see that the baffle is properly installed over the air tube and locking pin is installed

Understanding & Operating Your Pacific Energy Fireplace

The Pacific Energy line of fireplaces is a culmination of years of research and development. Designed to be efficient, clean-burning and user-friendly, this heater will give you years of warm service. However, a knowledgeable operator is still the most important factor for maximum performance and part of this is understanding the basic functions of this design.

Traditional fireplaces had a basic combustion system which allowed a considerable amount of heat energy to escape up the chimney as unburned gases and particulates (smoke). Pacific Energy has designed a system that solves the problem by burning the smoke and releasing the additional heat to the room.

This system has two critical design features:

1. Above fire secondary air injection:

The hollow "air baffle" injects super-heated secondary air just above the load. With the fireplace at the proper operating temperature, this will create a secondary flame that will be evident for approximately 1/3 of the total burn time.

2. High mass and thermal insulation:

The high mass (weight) acts as a heat storage and the thermal insulation keeps the combustion zone hot. Active flaming takes place during the first part of the burn. During this stage, heat is stored in the mass of the unit and is later released slowly and evenly. As wood chars, active flaming will diminish. This clean charcoal burning stage will last for a considerable length of time and refuelling should be avoided until the charcoal base has become quite small.

OPERATING TIPS

1. Always use dry, seasoned firewood, up to 18"(46cm) long. Load wood endwise, a mixture of large and small pieces, on top of a good ash base (1"(25mm) minimum)).
2. Operate on a medium to high setting, for up to 1 hour from cold start. After the initial warm up period, refuel and leave the air control on a medium setting for 5 to 10 minutes more and then set the air control to the desired position.
3. If a slow burn is desired, set the air control to low. Active secondary burning should be present above the wood load. If it is not present or goes out shortly after, proper operating temperature has not been reached and the fireplace needs additional warm up time.

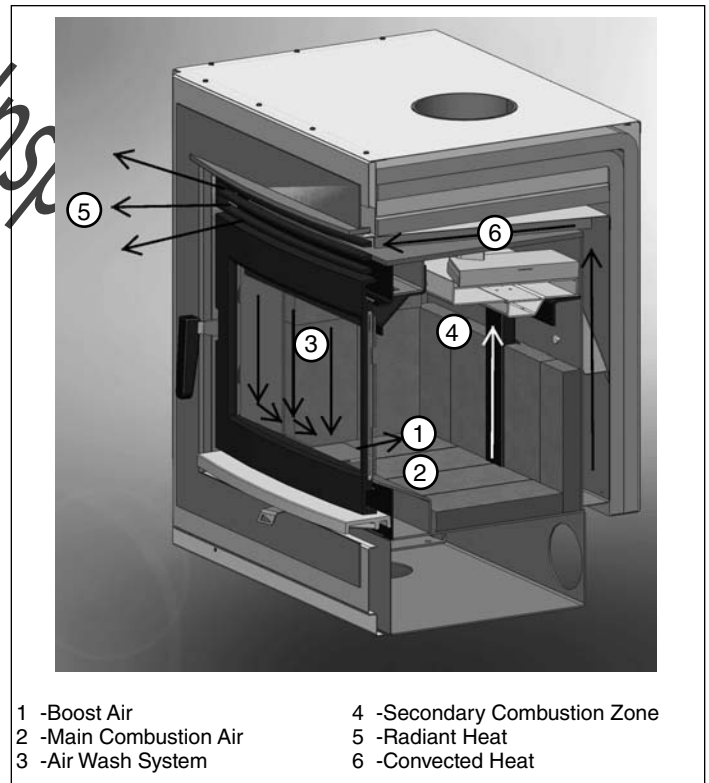

Replacement Parts

ITEM	DESCRIPTION	PART NO.	
1.....	Quadrant	7953	13.....
2.....	Blower Assembly, LHS	NE16.7844	Front Trim Plate, Black.....
.....	Blower only, LHS	5024.701	Front Trim Plate, Stainless Steel.....
3.....	Blower Assembly, RHS.....	NE16.78445	14.....
.....	Blower only, RHS	5024.700	Firebrick Set
3a.....	Thermoswitch.....	5027.2	15.....
4.....	Door Gasket.....	WODC.NEODGKIT	Framing Kit.....
5.....	Glass Retainer	NE16.7818	
6.....	Replacement Glass (c/w Tape)	NE16.5034700	
7.....	Door Casting	5037.700	
*	Arch Door Casting.....	5037.716	
8.....	Door Handle Assembly.....	NE16.7817	
9.....	Replacement Baffle Kit.....	NE16.BAFKIT	
10.....	Brick Rail Kit.....	NE16.INSRAILSET	
11.....	Door Catch	NE16.7825	
12.....	Surround Backing Plate.....	7955	

*NOT SHOWN

All parts may be ordered from your nearest Pacific Energy dealer. Contact Pacific Energy for the location of the dealer nearest you.

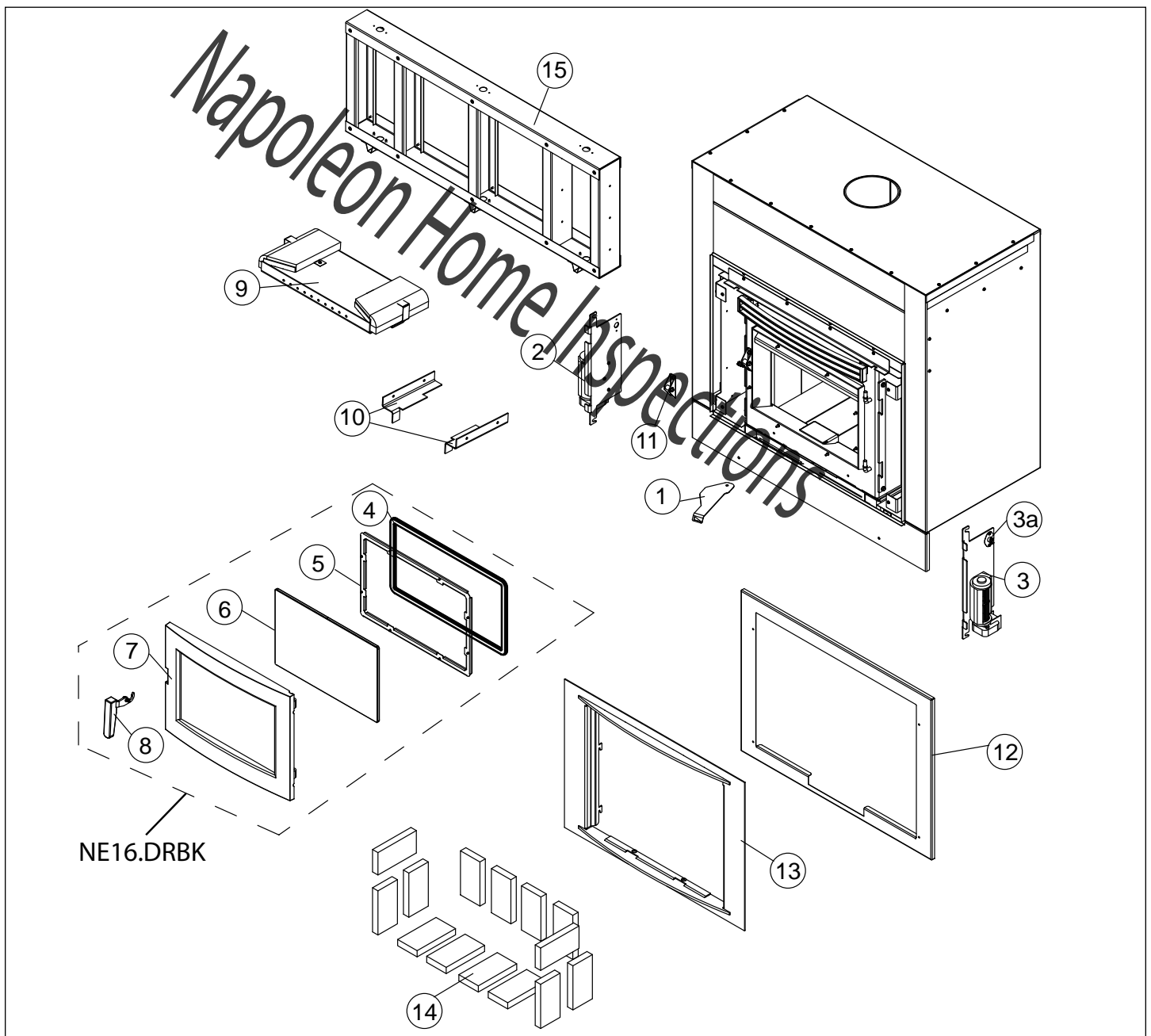

Warranty Information

Pacific Energy Limited Lifetime Warranty Wood Products

Pacific Energy extends the following warranty coverage to the original registered purchaser of the product:

LTD Lifetime Coverage (10 years)

Limited lifetime coverage is extended to the following components (parts only) porcelain finish, glass (glass for thermal breakage only, not impact), plating, firebox and baffle.

3 Year Comprehensive

Pacific Energy will replace or repair any part found to be defective (parts and labor) for three years from the date of purchase.

This coverage includes electrical components (blowers, speed controls and thermal switches).

Conditions:

Your stove has been designed to perform in the harshest climates in North America. You can be confident that under normal use your stove will be trouble free for many years. If your stove is prematurely deteriorating this is a significant indicator of improper usage, for example; excessive draft, heating to large an area, contaminated fuel - such as high sodium content or plastics and chemicals. Please be aware, these conditions may be reasons to void your warranty.

For wood products - All installations must be installed according to all applicable local and national codes. It is the responsibility of the installer to ensure the unit is operating correctly at installation.

Any part that shows in our judgment evidence of defect shall be repaired, replaced or refunded at Pacific Energy's option. The defective part may be required to be returned to Pacific Energy or an accredited agent, transportation prepaid.

Porcelain is warranted for gloss retention. Certain colors may darken when heated and return to the original shade when cool.

Glass is warranted against thermal breakage.

Plating is warranted against tarnishing. Gold plating may attain a deeper color with use.

Exclusions

Limited Lifetime coverage - Lifetime coverage is limited to the repair, replacement or refund of the indicated parts only. Labor charges are not covered under the lifetime warranty.

The following items are not included in the Lifetime Warranty: firebox rails and heat shields.

The following parts are not warranted: firebrick, gaskets and ceramic fiber blankets.

This warranty does not apply to any part that shows evidence of misuse, abuse, improper installation, accident, lack of maintenance, or modification.

Pacific Energy shall in no event be liable for any special, indirect or consequential damages of any nature whatsoever which are in excess of the original purchase price of the product.

Pacific Energy is not responsible for installation, operational or environmental conditions beyond our control. (The company may, at its discretion, discharge all obligations by refunding the wholesale price of the defective part.)

For Warranty claims, please contact your nearest Pacific Energy dealer.

Napoleon Home Inspections

Label

Label Location

The rating label is located on the rating label plate which can be accessed by removing the inner and outer surrounds. The plate is placed in the slot in the front face of the support base. Remove to view label.

Rating Label



Intertek
ETL#4001507

DO NOT REMOVE THIS LABEL/ NE RETIREZ PAS CETTE ÉTIQUETTE **SN-404**
CERTIFIED FOR CANADA AND U.S.A./LISTED FACTORY BUILT FIREPLACE. CERTIFIED TO ULC S610-M87 AND CONFORMS TO UL 127-2011
FOYER PRÉFABRIQUÉ HOMOLOGUÉ / CERTIFIÉ POUR UTILISATION AU CANADA ET AUX É.-U. TESTÉ SELON ULC S610-M87 ET UL 127-2011.
SERIES/SÉRIE: A MODEL/ MODÈLE: FP16 ■ FP16AR ■

- INSTALL AND USE IN ACCORDANCE WITH THE INSTALLATION AND OPERATING INSTRUCTIONS SUPPLIED WITH THE APPLIANCE. • AREAS OF THE FIREPLACE INCORPORATING WARM OR COLD AIR DUCTS SHALL BE ENCLOSED IN ACCORDANCE WITH THE INSTALLATION AND OPERATING INSTRUCTIONS SUPPLIED WITH THE APPLIANCE. SEE MANUFACTURER'S INSTALLATION AND OPERATING INSTRUCTIONS FOR THIS MODEL.
- CONTACT LOCAL BUILDING OR FIRE OFFICIALS ABOUT RESTRICTIONS, INSTALLATION PERMIT AND INSPECTION IN YOUR AREA. • DO NOT CONNECT THIS UNIT TO A CHIMNEY FLUE SERVING ANOTHER APPLIANCE
- DO NOT OBSTRUCT THE OPENINGS IN FRONT OF THE FIREPLACE OR OTHERWISE RESTRICT SUPPLY AIR NECESSARY FOR NORMAL FIREPLACE OPERATION AS SPECIFIED IN INSTALLATION AND OPERATING INSTRUCTIONS SUPPLIED WITH THE APPLIANCE. INADEQUATE AIR SUPPLY FOR COMBUSTION, VENTILATION AND DILUTION MAY RESULT IN DANGEROUS OPERATION OF THIS AND OTHER APPLIANCES.
- SEE LOCAL BUILDING CODE AND MANUFACTURER'S INSTRUCTIONS FOR PRECAUTIONS REQUIRED WHEN PASSING A CHIMNEY THROUGH A COMBUSTIBLE WALL OR CEILING. CHIMNEY SYSTEM MUST BE LISTED TO: IN CANADA - USE CHIMNEY LISTED TO ULC-S-629, IN USA - UL-103 HT LISTED CHIMNEY • OPTIONAL COMPONENTS: FRESH AIR KIT
- OPERATE ONLY WITH FEED DOOR CLOSED. OPEN TO FEED FIRE ONLY.
- FOR SOLID WOOD FUEL ONLY. • BLOWER ELECTRICAL RATING 115V, 60HZ, 1.1AMP • REPLACE GLASS ONLY WITH 5mm CERAMIC GLASS.
- DO NOT USE OR INSTALL COMPONENTS OR PRODUCTS NOT SPECIFIED IN PACIFIC ENERGY INSTALLATION INSTRUCTIONS. DO NOT USE A FIREPLACE INSERT OR OTHER PRODUCTS NOT SPECIFIED FOR USE WITH THIS PRODUCT. • THIS FIREPLACE HAS NOT BEEN TESTED WITH AN UNVENTED GAS LOG SET. TO REDUCE RISK OF FIRE OR INJURY, DO NOT INSTALL AN UNVENTED GAS LOG SET INTO FIREPLACE.

MINIMUM CLEARANCES TO COMBUSTIBLE MATERIALS/ DÉGAGEMENTS MINIMUMS AUX MATÉRIEAUX COMBUSTIBLES

CLEARANCES TO SIDE AND BACK STANDOFFS/ DÉGAGEMENTS	0 in. / 0 mm
A. CHASE ENCLOSURE WIDTH/ LARGEUR DE CLÔTURE DE POURSUITE	42 in. / 107mm
B. CHASE ENCLOSURE DEPTH/ PROFONDEUR DE CLÔTURE DE POURSUITE	24 in. / 610mm
C. CORNER TO SIDEWALL/ COIN AU MUR LAT.	2 in. / 51mm
D. FRAMING OPENING/ OUVERTURE DE CADRAGE	42 in. / 107mm
E. CEILING TO UNIT/ DU PLAFOND AU FOYER	33 in. / 838mm
NON-COMBUSTIBLES ONLY IN THE SPACE ABOVE UNIT TO CEILING, NOT INCLUDING APPROVED FRAMING / NON-COMBUSTIBLES SEULEMENT AU-DESSUS FOYER À PLAFOND	***
F. BASE OF UNIT TO MANTEL/ BASE DE L'UNITÉ AU MANTEAU	18 in. / 457 mm
G. EMBER PROTECTION FROM FRONT OF UNIT/ PROTECTEUR de PLANCHER À L'AVANT DU FOYER	8 in. / 203 mm
H. EMBER PROTECTION TO SIDE OF UNIT/ PROTECTEUR de PLANCHER AU CÔTÉ DU FOYER	8 in. / 203 mm

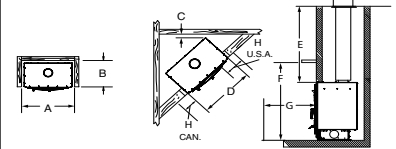

*** MANTEL HEIGHT MUST BE MEASURED FROM THE BASE OF THE UNIT AS FOLLOWS: 46 1/2" (1.18m) FOR A 4" (102mm) DEEP MANTEL UP TO 50 1/2" (1.28m) FOR A 12" (305mm) DEEP MANTEL. SEE THE INSTALLATION AND OPERATING INSTRUCTIONS FOR OTHER GRADUATED MEASUREMENTS FOR MANTEL HEIGHTS AND DEPTHS BETWEEN 4" (102mm) AND 12" (305mm).

LE SYSTÈME DE CHEMINÉE DOIT ÊTRE HOMOLOGUÉ COMME SUIT : AU CANADA - CHEMINÉE HOMOLOGUÉE ULC-S-629, AUX ÉTATS-UNIS - CHEMINÉE HOMOLOGUÉE UL-103 HT.

- INSTALLEZ ET UTILISEZ SELON LES INSTRUCTIONS D'INSTALLATION ET D'UTILISATION FOURNIES AVEC LE FOYER.
- LES PARTIES DU FOYER INCORPORANT DES CONDUITS CHAUDS OU FROIDS DOIVENT ÊTRE ENCHÂSSÉES, CONFORMÉMENT AUX INSTRUCTIONS D'INSTALLATION ET D'UTILISATION FOURNIES AVEC LE FOYER.
- CONTACTEZ LES AGENTS LOCAUX DU CODE DU BÂTIMENT OU DU SERVICE-INCENDIE POUR LES RESTRICTIONS, PERMIS D'INSTALLATION ET EXIGENCES D'INSPECTION DANS VOTRE RÉGION.
- NE RACCORDEZ PAS CE FOYER À UN CONDUIT DE CHEMINÉE DESSERVANT UN AUTRE APPAREIL
- NE PAS OBSTRUER PAS LES OUVERTURES DEVANT LE FOYER, NI RESTREINDRE L'ALIMENTATION D'AIR NÉCESSAIRE POUR LE FONCTIONNEMENT NORMAL DU FOYER, TEL QUE SPÉCIFIÉ DANS LES INSTRUCTIONS D'INSTALLATION ET D'UTILISATION FOURNIES AVEC L'APPAREIL. LA PROVISION INADEQUATE D'AIR POUR COMBUSTION, MAI DE VENTILATION ET DILUTION A POUR RESULTAT L'OPERATION DANGEREUSE DE CE CI ET AUTRES APPAREILS.
- VOIR LE CODE DU BÂTIMENT LOCAL ET LES INSTRUCTIONS DU FABRICANT, POUR LES PRÉCAUTIONS EXIGÉES LORSQU'UNE CHEMINÉE TRAVERSE UN MUR OU PLAFOND EN MATÉRIEAUX COMBUSTIBLES.
- COMPOSANTS OPTIONNELS: KIT DE PRISE D'AIR
- UTILISEZ LES COMPOSANTS SPÉCIFIÉS DANS LES INSTRUCTIONS D'INSTALLATION DE PACIFIC ENERGY.
- UTILISEZ SEULEMENT AVEC LA PORTE DE CHARGEMENT FERMÉE. NE L'OUVREZ QUE POUR ALIMENTER LE FEU.
- POUR COMBUSTIBLE SOLIDE SEULEMENT. • REMPLACEZ LA VITRE SEULEMENT PAR UNE VITRE EN CÉRAMIQUE. • LA SOUFFLERIE CLASSEMENT ELECTRIQUE 115V, 60 Hz, 1.1AMP
- CETTE CHEMINÉE n'A pas ETE ESSAYÉE AVEC UN UNVENTED JOURNAL DE GAZ A REGLE. POUR REDUIRE LE RISQUE DE FEU OU BLESSURE, LE PAS INSTALLE UN UNVENTED JOURNAL DE GAZ A REGLE DANS CHEMINÉE.



CAUTION

HOT WHILE IN OPERATION. DO NOT TOUCH. KEEP CHILDREN, CLOTHING AND FURNITURE AWAY. CONTACT MAY CAUSE SKIN BURNS. SEE NAMEPLATE AND INSTRUCTIONS. / DEVIENT TRÈS CHAUD. NE TOUCHEZ PAS. ÉLOIGNEZ LES ENFANTS, LES VÊTEMENTS ET LES MEUBLES. UN CONTACT PEUT CAUSER DES BRÛLURES. VOIR LA PLAQUE SIGNALÉTIQUE ET LES INSTRUCTIONS.

U.S. ENVIRONMENTAL PROTECTION AGENCY CERTIFIED TO COMPLY WITH JULY, 1990, PARTICULATE EMISSION STANDARDS/ CERTIFIÉ CONFORME AUX NORMES LES ÉMISSIONS DE PARTICULES (JUILLET 1990).

MANUFACTURED BY/ FABRIQUÉ PAR :
PACIFIC ENERGY FIREPLACE PRODUCTS LTD.
2975 ALLENBY RD., DUNCAN, BC V9L 6V8



DATE OF MANUFACTURE/ DATE DE FABRICATION

J	F	M	A	M	J	J	A	S	O	N	D
2014	2015	2016	2017	2018	2019						

MADE IN CANADA/ FABRIQUÉ AU CANADA

121214

5050.7016

FP16-1

**PACIFIC
ENERGY**

Napoleon Home Inspections

PACIFIC ENERGY FIREPLACE PRODUCTS LTD.

2975 Allenby Rd., Duncan, B.C. V9L 6V8

For technical support, please contact your retailer.

Web site: <http://www.pacificenergy.net>

Printed in Canada