

FIREPLACE INSTALLATION

Install only in a masonry fireplace at least 26" (660mm) wide, 22" (530mm) high and with a masonry chimney at least 15' (4.6m) high, both of which have been constructed in accordance with the building code. Do not remove bricks or mortar from the fireplace.

1. Remove the fireplace damper or fasten it permanently open.

2. Measure the throat of the fireplace and mark this shape on a piece of 24 gauge sheet metal (flue cover); cut a six-inch (150mm) hole to lie directly below the fireplace flue opening. Allow two inches of material for a flange on each side and cut on the outside. Bend down the flanges. If you have ever done this before, it might be a good idea to make a cardboard pattern and test it first. Fasten this flue cover in position as high as possible with two masonry screws per side through the flanges into the fireplace (See Figure 8A).

3. Run a listed flexible stainless steel liner from the top of the chimney to the stove top. Connect to the stove using three screws and flat washers. Secure the top of the liner to the chimney cap using a liner support and chimney flashing. Cap the top of the chimney liner assembly using an approved rain cap.

REQUIRED MINIMUM CLEARANCES TO COMBUSTIBLES FROM INSERT:

- If the stove projects less than 3 1/2" (90mm) from the fireplace face, the clearances to combustibles are: 27 1/2" (700mm) to a combustible mantel or top facing; 9" (230mm) to a side facing and 12" (305mm) to a side wall.
- If the unit projects more than 3 1/2" (90mm) from the fireplace face, there must be no combustible mantel or top facing and 14" (355mm) minimum clearance to a combustible side wall.
- The hearth must extend at least 18" (405mm) from the stove front.
- These clearances may be reduced with suitable shielding acceptable to the local authority.

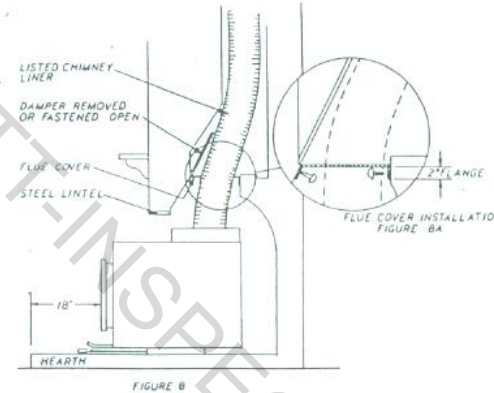

CERTIFICATION

All Napoleon stoves have been tested and listed by Warnock Hersey Ltd. to standards: CSA B366.2, ULC S627, ULC S628, UL 1482, UL 907.

Models 1000 and 1500 have been tested and listed for mobile homes.