

INSTALLER:

THESE INSTRUCTIONS  
MUST BE CONVEYED  
TO AND REMAIN WITH  
THE HOMEOWNER.

CERTIFIED UNDER CAN/  
ULC-S639 - M87 STEEL  
LINER ASSEMBLIES FOR  
SOLID FUEL BURNING  
MASONRY FIREPLACES



# FIREPLACES

NM2020

## PRESTIGE MASONRY SYSTEM

OWNER'S MANUAL

INSTALLATION AND OPERATION

INSTRUCTIONS

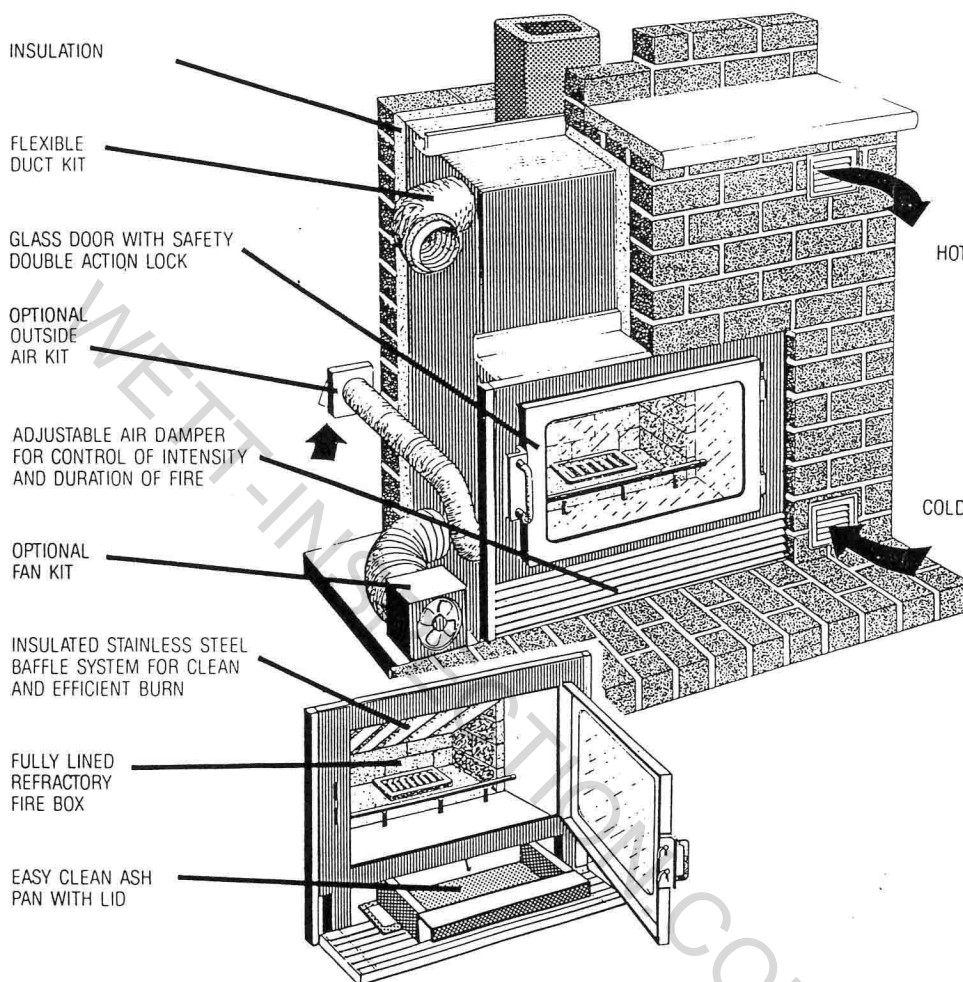

MANUFACTURED BY: WOLF STEEL LTD.,  
R.R.#1 BARRIE, ONTARIO, CANADA, L4M 4Y8  
(705)721-1212, FAX (705)722-6031.



## INTRODUCTION

YOUR NEW FIREPLACE IS A HIGH EFFICIENT AIRTIGHT HEATER THAT WILL GIVE YOU MANY YEARS OF SERVICE AND COMFORTABLE HEAT. TO ENSURE SAFE, CORRECT INSTALLATION, PROPER OPERATION AND MAINTENANCE BE SURE TO READ THESE INSTRUCTIONS BEFORE INSTALLING THE FIREPLACE. FAILURE TO DO SO COULD RESULT IN A SERIOUS FIRE HAZARD.

THIS FIREPLACE WAS TESTED TO CAN/ULC - S639 - M87 STEEL LINER ASSEMBLIES FOR SOLID FUEL BURNING MASONRY FIREPLACES. IN ACCORDANCE WITH THIS STANDARD, THE UNIT MAY BE CONNECTED TO ANY ACCEPTED HIGH TEMPERATURE CHIMNEY SYSTEM LISTED TO ULC-S629. ALL CLEARANCES TO COMBUSTIBLE FRAMING REMAIN UNCHANGED AND VENTING CONNECTION MUST BE IN COMPLIANCE WITH THE CHIMNEY MANUFACTURERS INSTALLATION INSTRUCTIONS OR, IF MASONRY, MEET THE APPROPRIATE REQUIREMENTS OF THE BUILDING CODE.

DIAGRAM A

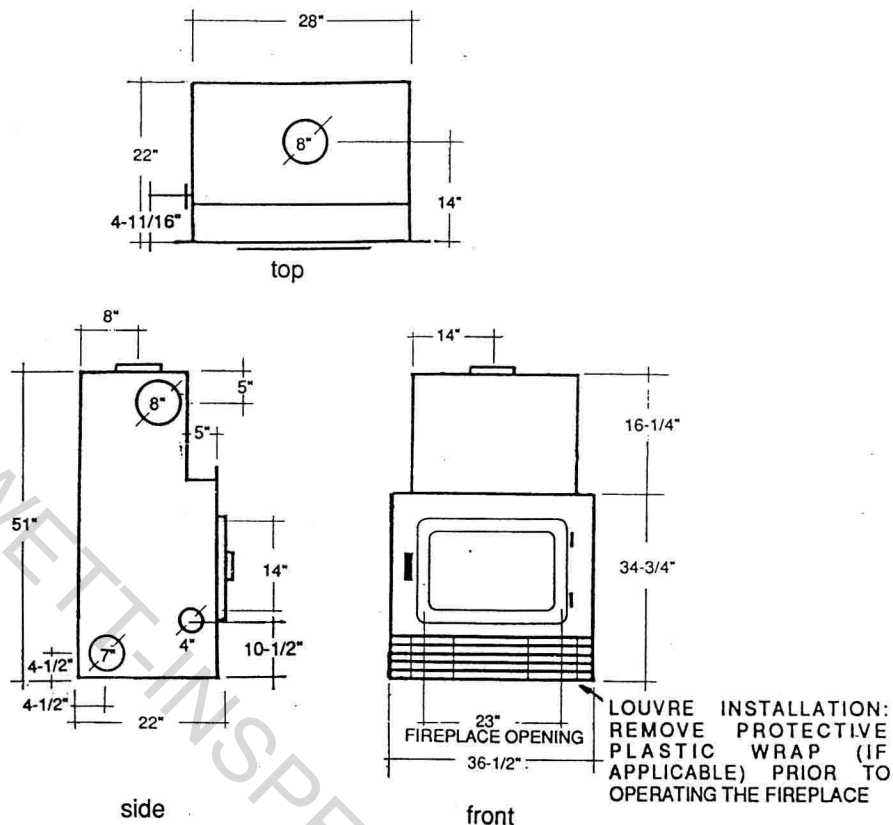

Consult the authority having jurisdiction (such as municipal building department, fire department, fire prevention bureau, etc.) to determine the need to obtain a permit.

If you are in doubt about proper installation in your situation, contact your dealer, local building or fire official.

Your Napoleon fireplace must be installed in accordance with all national and local building code

standards and the standard of Chimney & Fireplaces, Vents and Solid Fuel Burning Appliances NFPA No. 211.

Clearances referred to throughout this manual are the minimum requirements.

**THESE INSTRUCTIONS MUST BE FOLLOWED EXPLICITLY. FAILURE TO DO SO MAY RESULT IN HAZARDOUS CONDITIONS. DO NOT USE MAKESHIFT COMPROMISES DURING INSTALLATION.**

## GENERAL NOTES

The fireplace must not be installed against a vapour barrier or exposed insulation.

The fireplace can be built directly at floor level or on a raised hearth.

The fireplace must only be operated with the doors fully closed or with the optional Napoleon firescreen (Keep the ashpan door closed during operation).

The minimum distance between the fireplace opening and adjacent walls at right angles to the fireplace is 21 inches.

A wood mantle, if installed, must be at least 44 inches above the base of the fireplace.

The hearth extension must not be built higher than the bottom of the fireplace.

Keep furnishings and combustibles well away from the fireplace.

Maintain adequate clearances from combustibles above and in front of the hot air grilles.

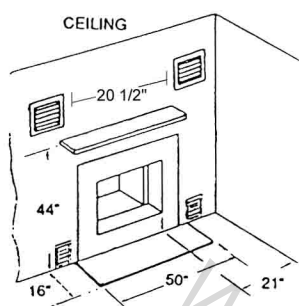

**LOCATION**

If the accessory hot air vent louvres are used, 2 openings 12" square and 20-1/2" apart should be cut in the wall.

The most desirable and beneficial location for a Napoleon Fireplace is in the centre of a building, thereby allowing the most efficient use of the heat created. The location of windows, doors and the traffic flow in the room where the fireplace is to be located should be considered. If possible, you should choose a location where the chimney will pass through the house without cutting floor or roof joists. The masonry material absorbs some of the heat generated and will continue to be a source of heat for some time after the fire has gone out.

## RECOMMENDED FOOTING

Depth - 12"

Width - perimeter of the structure plus 16"

## OUTSIDE COMBUSTION AIR

**CAUTION:** This fireplace takes outside air directly into the firebox through the opening on the left hand side. Make sure if not using an outside air kit that the opening is not obstructed and enough air is supplied at all times to this outlet.

If the optional fresh air kit is installed, it must not draw air from the attic, or the garage. The fresh air must come from outside the house.

The maximum length of the 4 inch air duct is 20 feet; after 20 feet enlarge the duct to a 6 inch diameter.

1. Decide on the most convenient location for the fresh air inlet duct and register. The duct and register may be installed above or below floor level.

2. Make a 5 inch hole in an outside wall of the house. From outside, place the outside air register into the hole, open side down.

3. At each end carefully pull back the insulation and plastic cover exposing the flexible duct. Place the insulated flexible duct over the register tube and over the fireplace outside air connector. Carefully push the insulation and plastic cover back over the duct. Using the clamps, fasten the plastic cover in place on both sides.

Always provide a source of fresh air into the room in which the fireplace is installed. Failure to do so may result in air starvation of other fuel burning appliances and the possible development of hazardous conditions.

The optional Fresh Air Kit is available from your Napoleon / Wolf Steel Ltd. dealer.

## OPTIONAL FRESH OUTSIDE AIR KIT

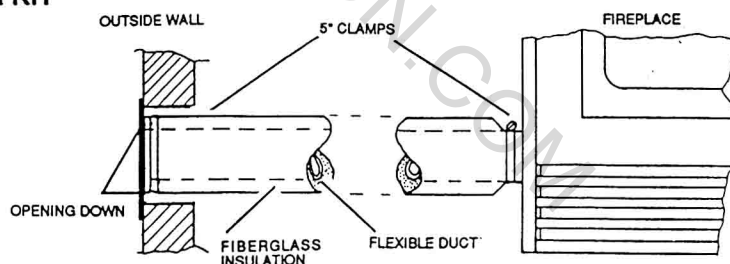

### HEARTH

A level non-combustible hearth, completely extending to all sides of the heat exchanger, must be constructed. The fireplace must be centered on the hearth.

### HEARTH EXTENSION

The hearth extension must comply with the National Building Code of Canada. The minimum non-combustible hearth extension requirements are:

16" in front of the unit and  
16" past the hearth opening on both sides

A raised hearth together with a hearth extension is recommended for easier wood loading and fire viewing.

### INSULATION

Use 1" high temperature insulation material as supplied. Completely cover the fireplace (top, sides and back) leaving only the front plate of the fireplace open.

### MASONRY

The sides and back of the heat exchanger are to be enclosed by 3-1/2" solid brick or 7-1/2" hollow brick. DO NOT COMPRESS OR REMOVE THE 1" INSULATION WHICH ACTS AS A HEAT EXPANSION AREA TO AVOID ANY PRESSURE ON THE HEAT EXCHANGER. See diagram B.

### HEAT EXCHANGER - COLD AIR OUTLETS

Use the aluminum flex pipe provided. C.S.A. fans may be installed in this area. These are available from your Napoleon / Wolf Steel Ltd. dealer.

### HEAT EXCHANGER - HOT AIR OUTLETS

The outlets must be connected and are to be built with an incline to permit the free flow of hot air from the heating unit. The outlets are to be no smaller than an 8"x8" or 8" diameter pipe.

Insulated aluminum flex pipe and firestop spacers are provided. A minimum 2" clearance to combustibles must be maintained from the flex pipe or 1" from the insulated sleeve.

Install the hot air ducts in an upward direction only. Never install in a downward direction. Make sure that the connections are done with at least 3 sheet metal screws and that the insulation covers the entire pipe. Use only approved hot air grills designed for the Napoleon NM2020, available from your authorized Napoleon dealer.

### FLUE TILE SUPPORT - MASONRY CHIMNEY

(Included with unit) See diagram C

The flue must be supported by masonry and may not rest on the top of the heat exchanger. Allow a 1/4" clearance. The flues must be made of vitrified clay and be in sizes of 8" square, 8"x12" or 8" round with a minimum height of 15 feet above the heat exchanger (**8" round flues are recommended**).

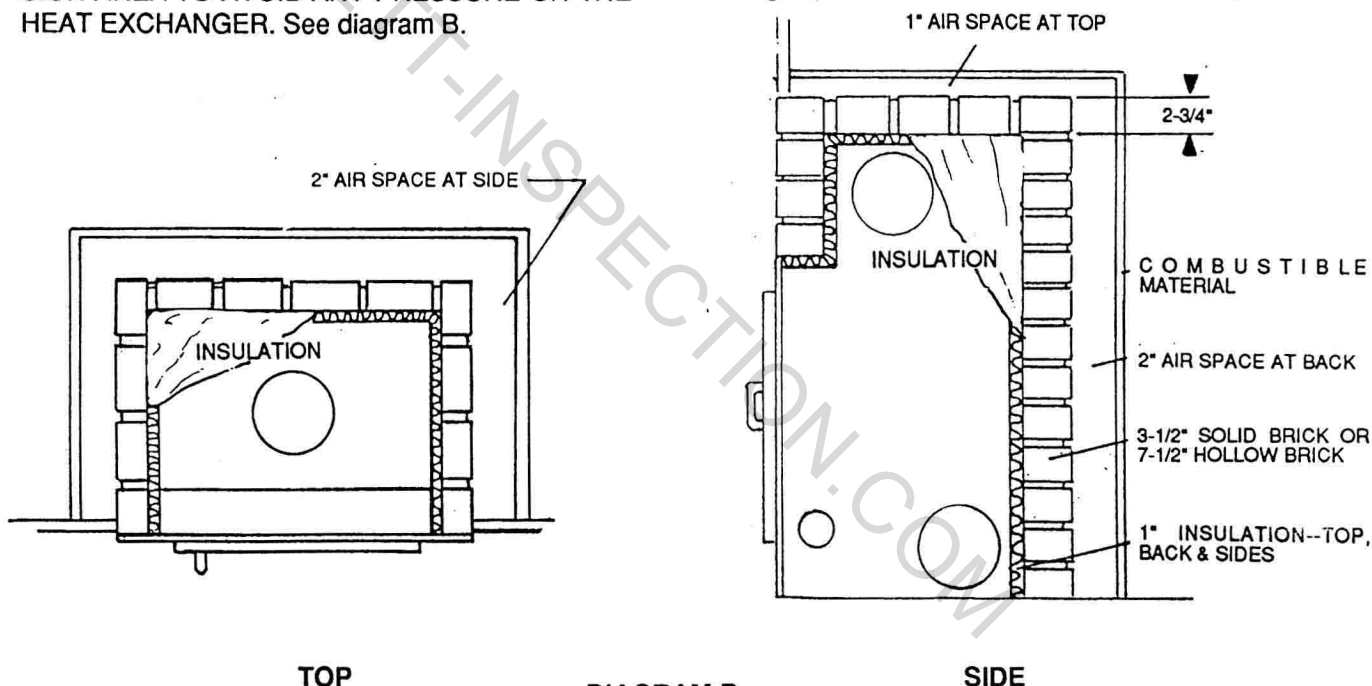

### CHIMNEY

The chimney venting a fireplace must not vent any other appliance. The minimum chimney height is 15 feet.

The chimney must extend at least 3 feet above its point of contact with the roof and at least 2 feet higher than any wall, roof or building within 10 feet of it

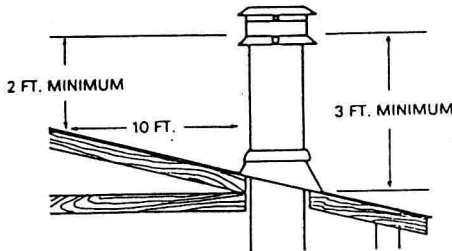

A raincap must be installed on top of the chimney. Failure to do so may cause the fireplace to corrode.

The joint between the fireplace and the chimney must be sealed with a high temperature sealant or gasket. The accumulation of soot may result in a potential fire hazard.

### MASONRY CHIMNEY

The chimney is to be supported by angle iron anchored into the masonry walls around the heat exchanger. The chimney must not rest on the heat exchanger (See diagram C).

The chimney should not be built with an offset angle to the heat exchanger in excess of 45 degrees.

The allowable masonry to be used in the chimney construction is 3-1/2" brick, solidly mortared and fully encasing the flue. Make sure there are NO LEAKS.

**DIAGRAM C**

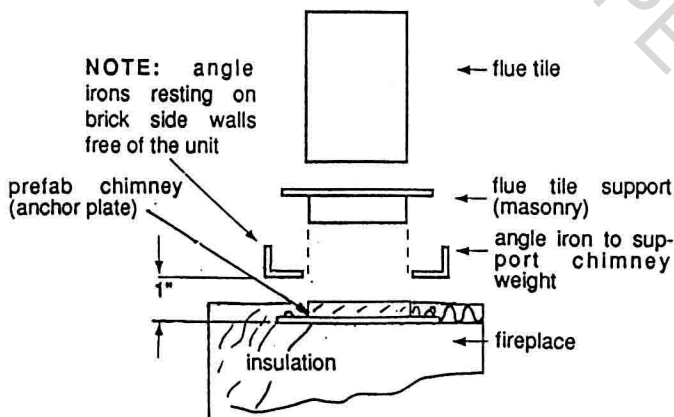

**DIAGRAM D :**

**TYPE 1 - Chimney system straight upward. No off-set. Min. height is 15 ft. overall from the top of the fireplace.**

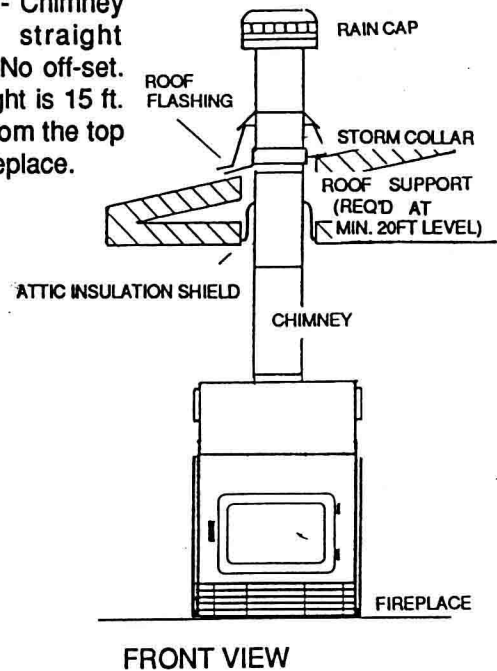

### FACTORY BUILT HIGH TEMPERATURE CHIMNEY

Use 7 inch inside diameter chimney.

Installation must conform to the chimney manufacturer's installation instructions. See diagrams D & E. Attach the chimney anchor plate to the top of the fireplace. The chimney must be supported at a maximum of 20 foot intervals.

If the chimney extends higher than 5 feet above the roof, it must be secured using a roof brace or guide wires.

**DIAGRAM E :**

**TYPE 2 - Single off-set with 2 -15°, 30°, or 45° elbows. Min. vertical chimney height is 15 ft.**

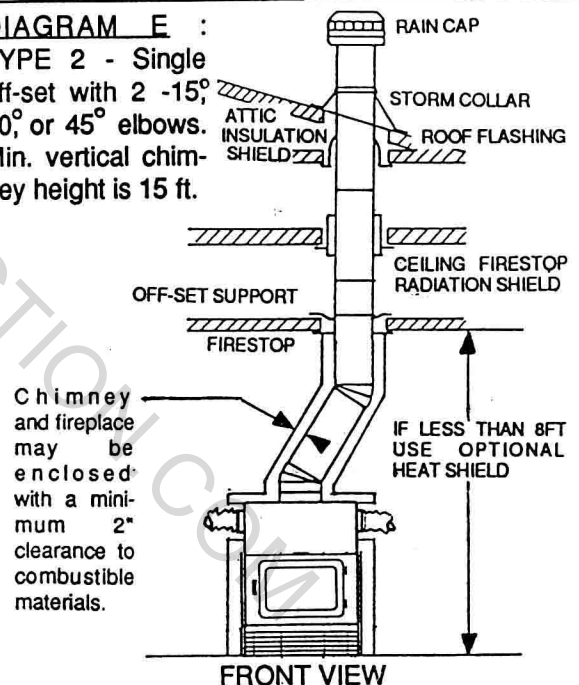

Portions of the chimney which may extend through accessible spaces must be encased in all cases to avoid personal contact with the chimney and thereby damage to the chimney.

Cut and frame square holes in all floors and ceilings and the roof to provide a 2" clearance between the chimney and any combustible material. DO NOT FILL THIS SPACE WITH ANY TYPE OF MATERIAL.

TYPICAL INSTALLATION	STRAIGHT UP	OFF-SETS (2 ELBOWS)
CHIMNEY MINIMUM HEIGHT (FT.)	15 FT. MIN.	15°-15 FT. MIN 30°-15 FT. MIN 45°-15 FT. MIN
RAFTERRADIATIONSHIELD	YES	YES
ATTIC INSULATION SHIELD	YES	YES
FIRESTOP SPACER ASSEMBLY	--	YES
INTERIOR OFF-SET SUPPORT	--	YES
VENTED ROOF FLASHING WITH STORM COLLAR	YES	YES
RAIN CAP	YES	YES

**GENERAL INSTALLATION VIEW:**

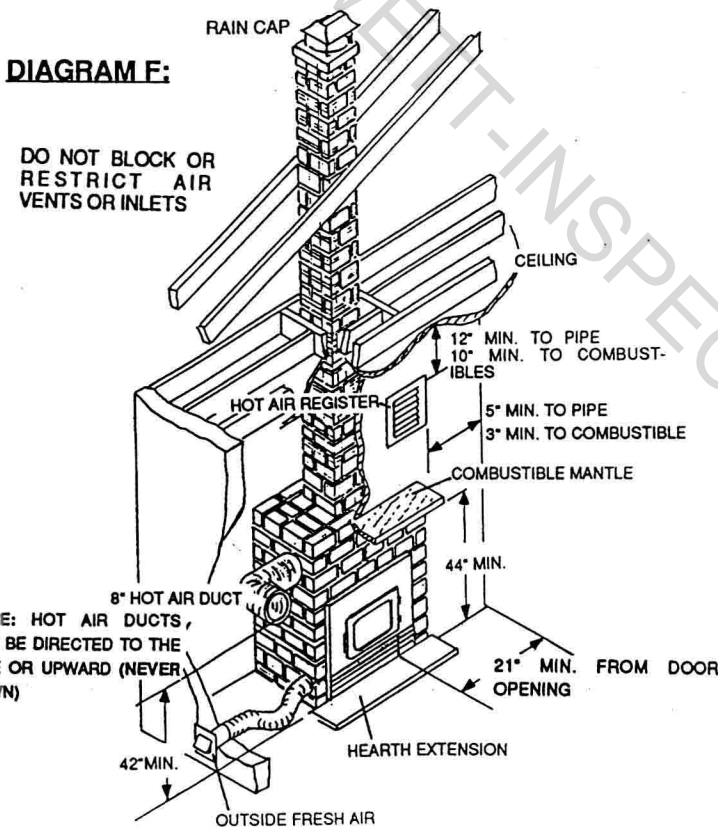

**DIAGRAM G:**

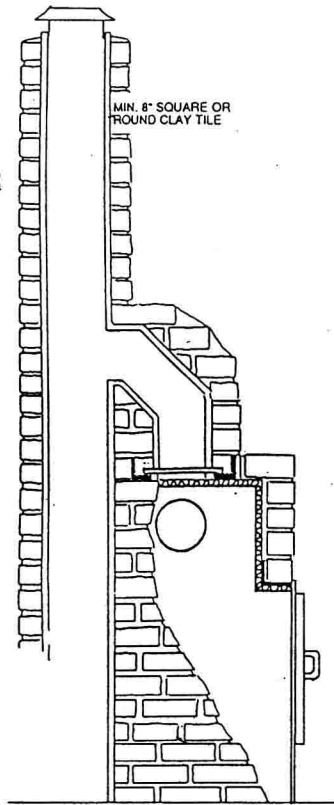

**CONNECTION TO EXISTING CHIMNEY**

The Napoleon Fireplace can be connected to either a lined or unlined chimney.

If the chimney is lined, refer to Diagram G. Installation must conform to both national and local code requirements.

If the chimney is not lined, a stainless steel liner, listed to standard ULC-S640M Liners for New Masonry Chimneys, may be used to connect the fireplace to the chimney. The liner must be continuous from the fireplace to the chimney cap. See Diagram H.

**DIAGRAM H:**

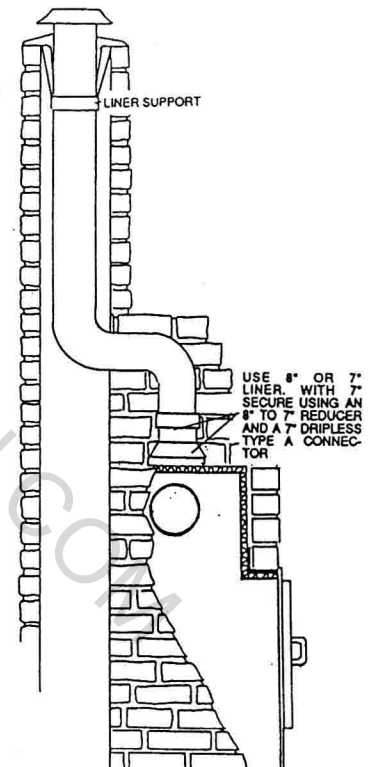



### ATTACHING THE HANDLE

Attach the handle as shown so that when the door is closed, the handle will be centred in the slot located on the fireplace front. To achieve this you may have to experiment (on the upper and lower screw) with one of the variations below. Tighten securely.

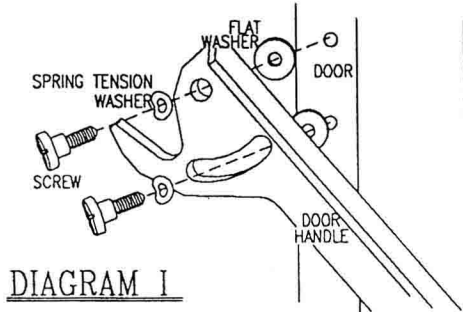
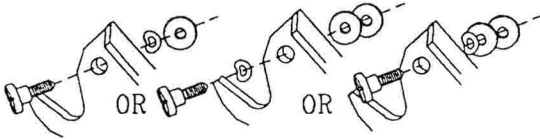

DIAGRAM I



### OPERATION

#### CAUTION

- Burn wood only.
- Build your fire on the hearth and behind the log retainer only.
- Never use gasoline, gasoline-type lantern fuel, kerosene, charcoal lighter fluid, or similar liquids to start or "freshen up" a fire. Keep all such liquids well away from the fireplace while in use.
- Always provide a SOURCE OF FRESH AIR FOR THE FIREPLACE.
- Keep the door of the fireplace closed during operation or fully open with the Napoleon screen.
- Combustible materials are not to be stored within 48" of the fireplace.
- Protect the chimney from moisture with a raincap.
- Contact with radiant surfaces may cause skin burns.

This fireplace was designed for burning solid fuel (e.g. wood, charcoal). You should not burn highly volatile fuels (e.g. paper, cardboard, gasoline, wax). Do not overfire. Keep fires away from the door and behind the log retainer.

Do not block the hot air vents or air inlets in the fireplace. This will cause the fireplace to overheat.

Do not operate the fireplace with the ashpan door open.

### IMPORTANT OPERATING INSTRUCTIONS FOR THE HOMEOWNER

Your Napoleon fireplace is a Hi-Tech unit, designed with the most advanced technology. The unit is very airtight and has exclusive direct outside air supply -- a safety feature designed to prevent spillage and to keep your house free of carbon monoxide in case of a downdraft or negative inside pressure. You will observe that the fire in your Napoleon fireplace burns differently than conventional fireplaces. The slow and lazy yet constant flames, large heat radiating glass surface and hot air circulation all work together to *return heat to your home*. A roaring fire, common to old fashioned wood burning appliances simply discharges a high volume of wasted heating energy up the chimney.

#### PLEASE FOLLOW THESE DIRECTIONS CAREFULLY:

Open the air control fully by sliding the lever to the right. During the break-in period (the first 2 to 3 fires) maintain only small fires using kindling: this will allow the firebrick to "cure". Do not be alarmed if small hairline cracks develop in the firebrick. This is a normal occurrence and does not pose a safety hazard.

To maintain a brisk fire, a hot coal bed must be established and maintained. To start, cover the firebox area with kindling, light and leave the glass door slightly ajar (one to two inches) until all kindling is burning.

Slowly add larger wood (2x4 inch size) crisscrossing them over the fire. When the fire seems to be at its peak, medium sized logs may be added. Once the larger logs have caught fire properly, carefully close the door. *Closing the door too quickly after re-fueling will reduce the firebox temperature and result in an unsatisfactory burn.* Remember, it is more efficient to burn medium sized wood briskly, and re-fuel frequently rather than load the fireplace with large logs resulting in a smouldering fire and dirty glass.

As soon as the door is closed, you will observe a change in the flame pattern. The flames will get smaller and "lazier" because less oxygen is allowed into the combustion chamber but they will become more efficient and larger again as soon as the firebricks have been heated properly and the heated chimney provides a good draft. The roaring fire that you see when the door is open is wastefully drawing heated room-air up the chimney. *Certainly not desirable.* So always operate the unit with the door fully closed.

You can now add larger pieces of wood and operate the fireplace normally.

Regulate the temperature by sliding the air control lever to the left. The flames will moderate and generate less heat. Allow several minutes for the fire to stabilize after adjustment.

**NOTE: WHEN FIRST LIGHTING A FIRE, IF THE SMOKE IS NOT QUICKLY DRAWN INTO THE CHIMNEY, THERE MAY BE A DOWNDRAFT OR COLD AIR IN THE CHIMNEY. ROLL UP SOME NEWSPAPER, LIGHT IT AND PLACE IT INTO THE FIREPLACE FLUE UNTIL THE CHIMNEY BEGINS TO DRAW. DURING A FIRING, OPEN THE AIR CONTROL BEFORE OPENING THE FIREPLACE DOOR. OPEN THE DOOR SLOWLY TO AVOID DRAWING SMOKE INTO THE ROOM. IN ORDER TO CURE YOUR FIREBRICK LINING, BUILD A SMALL FIRE FIRST.**

### **CONTROL OF BURNING RATE**

Because your fireplace is airtight, the only air intake will occur through the air inlet on the left side of the fireplace. The air inlet can be opened and closed by way of the air control lever located below the fireplace door. To open the air control, move the lever to the right. To close it, move the lever to the left. Once the fire is started and well underway, you can control the burning rate by adjusting the lever. Opening the control will cause the fire to burn more vigorously; closing it, to burn slower. Never operate the fireplace with the ashpan door open.

### **PAINT**

When you first use your fireplace, the high temperature paint that is used on the surface of the fireplace will smoke a little and give off an odour for several hours. This condition is temporary. Open the doors and windows to ventilate the room(s) sufficiently.

### **AIRWASH**

The air intake directs air over the glass and into the fire. This will keep the 'fire viewing' window clean for longer periods of time. Build-up on the glass depends also on what type of wood is used, on the burning rate and on the draft of the chimney.

### **WOOD**

Wet or unseasoned (green) wood is not recommended for use. It still contains a lot of moisture and therefore is heavier and harder to ignite, holding less energy, burning inefficiently, smoking more and clogging your chimney system with creosote --a tar-like *flammable substance*.

For these reasons, only hardwood that has been seasoned for several months should be used as fuel. Ideally, firewood should be cut, split and piled one heating season ahead. All dry wood has the same BTU factor per pound. Hardwood, however, (i.e. oak) is a denser wood and takes less space than softwood (i.e. pine). Therefore, one cord of oak has a higher energy value than one cord of pine. Hardwood burns longer and creates less creosote.

To store your wood, stack it so that both ends of the logs are exposed to air. Cover the top of your woodpile with plastic, scrap plywood, etc. Also stack firewood on smaller pieces of wood or similar items to allow air to circulate underneath.

### **CREOSOTE - FORMATION & THE NEED FOR REMOVAL**

When wood is burned slowly, it produces tar and other organic vapors, which combine with expelled moisture to form creosote. The creosote vapours condense in the relatively cool chimney flue of a slow burning fire. As a result, creosote residue accumulates on the flue lining. When ignited, this creosote residue becomes an extremely hot fire.

A slow burning or smouldering fire should not be maintained for any extended period of time. Periodically during the day build a hot fire to increase the flue temperature and reduce creosote accumulation. Deposits of creosote restrict the opening of the flue, interfere with your draft and can lead to a chimney fire.

In case of a chimney fire, which may produce a roaring sound and cause sparks to fly from the chimney, close the air control (and the door) immediately. Let the fire go out. Have your chimney inspected for any structural damage by someone knowledgeable.

The chimney should be inspected at least once every two months during the heating season to determine if a creosote build-up has occurred.

If creosote has accumulated, it should be removed to reduce the risk of a chimney fire.

Avoid the use of green, unseasoned wood or wood with more pitch content. Do not operate the fireplace in a choked down position over an extended period of time.

A hot fire is preferable to a smouldering one to reduce the amount of creosote.



### SMOKING & BACK-PUFFING

If your fireplace smokes after the chimney has warmed up, it is caused by insufficient draft of the flue system.

Check for the following:

1. Insufficient combustion air.
2. Creosote build-up.
3. Clogged chimney system.
4. Clogged spark arrestor.
5. Too many turns in the flue system.
6. Chimney not high enough.
7. Downdraft created by - blockage of the chimney outlet.  
- chimney installed on the leeward side of an obstruction.
8. Chimney pipe on the outside of the house cools too fast and there is not sufficient draft.
9. Porous masonry chimney.

### MAINTENANCE

Use only Napoleon replacement parts. Do not use substitute materials.

### CHIMNEY

Check your chimney frequently for creosote and soot build-up. If the accumulation is excessive, clean the chimney. You might want to call a professional chimney sweep to have this done. The chimney must be cleaned once a year or as often as necessary.

### FIREPLACE

Inspect the fiberglass rope on the door and around the ceramic glass from time to time for proper seal. Air leakage resulting from poorly sealing gaskets decreases the efficiency of your stove. A 1/2" door gasket and U-gasket is available from your Napoleon / Wolf Steel Ltd. dealer.

If you want to refinish your fireplace to its original good looks, use a quality high heat aerosol paint which is also available from your Napoleon / Wolf Steel Ltd. dealer. Before spray-painting the fireplace, remove any parts that you do not want painted. Rough up the existing paint with fine sandpaper or steel wool. Follow the directions on the paint can. Do not paint the fireplace when hot.

### DISPOSAL OF ASHES

Ashes should be placed into a metal container with a tight fitting lid. The closed container of ashes should be placed on a non-combustible floor or outside on the ground, well away from all combustible materials, pending final disposal. If the ashes are disposed of by burial in the soil or otherwise locally dispersed, they should be retained in the closed container until all cinders have thoroughly cooled.

For your convenience an ashpan complete with lid is included with this fireplace.

### GLASS CARE

Ceramic glass is used as the fire-viewing window of your Napoleon Fireplace. Ceramic glass has well established and recognized heat resistance and strength characteristics. It can only be broken through improper use or impact. Do not slam the fireplace door or otherwise impact the glass. When closing the door, make sure that no logs or other objects protrude to impact against the glass.

Do not clean the glass with materials which may scratch or otherwise damage the glass. Scratches on the glass can develop into cracks and breaks. Non-abrasive cleaners are available from your dealer. Never attempt to clean the glass while it is hot. Never put substances which can ignite explosively in the stove since even small explosions in confined areas can blow out the glass. Inspect the glass regularly for cracks and breaks. If you find any, extinguish the fire immediately and return the door, which unhinges easily, to your Napoleon / Wolf Steel Ltd dealer for glass replacement before further use. Tempered or ordinary glass will not withstand the high temperatures. Use only 3/16 (5mm) thick ceramic glass as a replacement.

### BRASS & 24 KARAT GOLD PLATED PARTS

Your fireplace may be highlighted by brass or gold plating. Do not use abrasive cleaners to clean these parts. Buff lightly with a clean dry cloth.

**DO:**

1. BUILD A HOT FIRE.
2. USE ONLY DRY WOOD.
3. SEVERAL PIECES OF MEDIUM SIZED WOOD ARE BETTER THAN A FEW BIG PIECES.
4. REFUEL FREQUENTLY USING MEDIUM SIZED WOOD.
5. 'FINE TUNE' THE AIR SETTINGS FOR OPTIMUM PERFORMANCE.
6. CLEAN CHIMNEY REGULARLY.

**DON'T:**

1. TAKE ASH OUT IMMEDIATELY. LET IT ACCUMULATE TO AT LEAST ONE INCH IN DEPTH. A GOOD LAYER OF ASH PROVIDES FOR A LONGER LASTING AND BETTER BURNING FIRE.
2. BURN WET WOOD.
3. CLOSE THE FUEL DOOR TOO SOON OR DAMPER DOWN TOO QUICKLY.
4. BURN ONE LARGE LOG RATHER THAN 2 OR 3 SMALLER, MORE REASONABLY SIZED ONES.
5. BURN AT CONTINUALLY 'LOW SETTING'. IF THE GLASS DOOR IS CONSTANTLY BLACKENED, THE FIREBOX TEMPERATURE IS TOO LOW.

**NAPOLEON  
25 YEARS LIMITED WARRANTY**

Wolf Steel Ltd. warrants its NAPOLEON MASONRY FIREPLACE against manufacturing defects to the original purchaser only, subject to the following conditions:

1. Wolf Steel Ltd. will provide replacement parts free of charge during the first year of the Limited Warranty except plated finishes, glass, fibre seal log retainer and refractory.  
All repair work, however, requires the prior approval of an authorized company official. Labour costs for account of Wolf Steel Ltd. shall not exceed the retail price of the replacement parts.
2. Wolf Steel Ltd. will provide replacement parts during the second through the fifth year of the Limited Warranty free of charge except the plated finishes, glass, fibre seal, log retainer, refractory, grate and fan. Wolf Steel Ltd. will not be responsible for any labour costs in connection with those replacement parts.
3. Wolf Steel Ltd. will provide replacement parts (if available) at 50% of the retail price during the sixth through the twenty-fifth year of the Limited Warranty except the plated finishes, glass, fibre seal, log retainer, refractory, grate, and fan. Wolf Steel Ltd. will not be responsible for any labour costs in connection with those replacement parts.

Fireplaces are warranted only if protected from moisture with a raincap on top of the chimney. The manufacturer is not extending this Limited Warranty nor will he be responsible or liable, in any way, for damages or losses caused by, or arising from, accident, improper installation, handling or operation, abuse, poor maintenance or unauthorized repairs or changes made to the original design of the fireplace in question.

If you have to make a claim under this Limited Warranty, contact the dealer from whom you bought the unit or the manufacturer. You will have to pay for shipping and inspection charges. All parts are F.O.B. Barrie, Ontario.

**IMPORTANT: KEEP THE ORIGINAL INVOICE SINCE A PHOTOCOPY OF IT WILL BE REQUIRED IN CASE OF CLAIM.**

**WOLF STEEL**<sup>®</sup>

RR#1 Barrie, Ontario,  
Canada L4M 4Y8  
Phone 705-721-1212  
Fax 705-722-6031

